



New generation (NG) radio

Course Contents/Background Material

Information status:

June 2000

BMW
Service Training

Contents



	Page
CHAP 1 "New generation" (NG) radios	1
Introduction	1
General	1
Overview of the radios on each model	2
Radio receiver installation locations	3
The appearance of the radios	4
Functions	9
NG radios	9
MIR	13
BM radio	17
System overview	18
NG radio system diagram	18
Test mode	20
Radio	20
Navigation	22
NG radio connector pinouts	25
E46 radio connector pinouts	25
E39, E52, E53 radio connector pinouts	26
Abbreviations	27

"New generation" (NG) radios

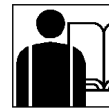

Introduction

General

A new generation of radios will gradually be introduced into the various models from September 2000. The radios have increased functionality and, with the exception of the ECE versions, are world band radios.

There is no switchover to NG radios on the E38 model.

The familiar radio categories are kept:

- Reverse
- Business
- Professional

And the variants also remain the same:

- Reverse
- Business without MID (multi information display)
- Business with MID
- Business with BM (on-board monitor)
- Business MIR (multi information radio)
- Professional with MID
- Professional with BM

Start of installation in the various models

Radio	Type	E39	E46	E52	E53
C42 *1	Reverse	-	SE	-	-
C52	Reverse	09/00	-	-	10/00
C53	Business	09/00	03/01	-	10/00
C53	Business MIR	-	03/01	-	-
C53	Business MIR without cassette	-	-	SE	-
C53	Business with MID	09/00	-	-	10/00
CD53	Business	-	03/01	-	-
CD53	Business with MID	09/00	-	-	10/00
MD53	Business	-	03/01	-	-
MD53	Business with MID	09/00	-	-	10/00
CD54	Professional	-	03/01	-	-
CD54	Professional with MID	09/00	-	-	10/00
BM53	Business with BM	02/01	03/01	-	04/01
BM54	Professional with BM	02/01	03/01	-	04/01

SE = from series launch
*1 not an NG radio

Overview of the radios on each model



E39

Radio	Type	520i 525i 520d 525d	530i 530d	535i 540i M5	520i 525i 520d 525d	530i 530d	535i 540i M5
C52	Reverse	Standard	-	-	-	-	-
C53	Business	-	Standard	-	Option	-	-
C53	Business with MID	-	-	Standard	Option	Option	-
CD53	Business with MID	-	-	-	Option	Option	Option
MD53	Business with MID	-	-	-	Option	Option	Option
CD54	Professional with MID	-	-	-	Option	Option	Option
BM53	Business with BM	-	-	-	Option	Option	Option
BM54	Professional with BM	-	-	-	Option	Option	Option

E46

Radio	Type	All models
C42*1	Reverse	Option
C53	Business	Option
C53	Business MIR	Option
CD53	Business	Option
MD53	Business	Option
CD54	Professional	Option
BM53	Business with BM	Option
BM54	Professional with BM	Option

*1 not an NG radio

E52

Radio	Type	Z8
C53	Business MIR without cassette	Standard

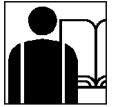
E53

Radio	Type	X5 3.0i X5 3.0d	X5 4.4i	X5 3.0i X5 3.0d	X5 4.4i
C53	Business	Standard	-	-	-
C53	Business with MID	-	Standard	Option	-
CD53	Business with MID	-	-	Option	Option
MD53	Business with MID	-	-	Option	Option
CD54	Professional with MID	-	-	Option	Option
BM53	Business with BM	-	-	Option	Option
BM54	Professional with BM	-	-	Option	Option

NG radio manufacturers

Radio	Type	Use	Manufacturer
C52	Reverse with cassette	ECE	Becker
C53	Business with cassette	World	Philips (E46)
C53	Business with cassette and MID	World	Philips (E39, E53)
C53	Business with cassette	ECE	Becker (E39, E53)
C53	Business MIR	World	VDO
CD53	Business with Compact Disc	World	Alpine
MD53	Business, with Mini Disc	World	Alpine
CD54	Professional with Compact Disc	ECE	Becker
BM53	Business with on-board monitor and cassette	World (excluding ECE)	Becker
BM54	Professional with on-board monitor and cassette	ECE	Becker

World: Europe, USA, Japan, Oceania, Canada

Radio receiver installation locations

The radio receivers are mounted in the instrument panel with the drives (cassette, CD, MD).

With the MIR, the radio receiver, LC display and control panel are contained within one unit.

With the BM, the radio receiver unit is housed in the luggage compartment as before.

The appearance of the radios



C52 Reverse



Fig. 1: Reverse NG radio (E39)

KT 5987

C53 Business



Fig. 2: Business NG radio (E39)

KT 5988



Fig. 3: Business NG radio (E39)

KT 5989

C53 Business for MID



Fig. 4: Business NG radio (E39, E53)

KT 5991

C53 Business with CD for MID



Fig. 5: Business NG radio with CD (E39, E53)

KT 5992



Fig. 6: Business NG radio with CD (E39) and MID

KT 5994

C53 Business with MD for MID

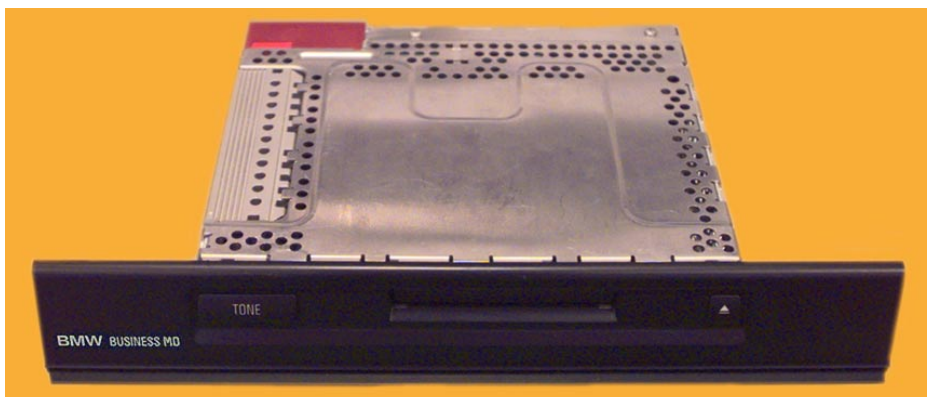

Fig. 7: Business NG radio with MD (E39, E53)

KT 5993

C53 Business MIR



Fig. 8: Business MIR NG radio (E46)

KT 5990

C53 Business / E52 MIR

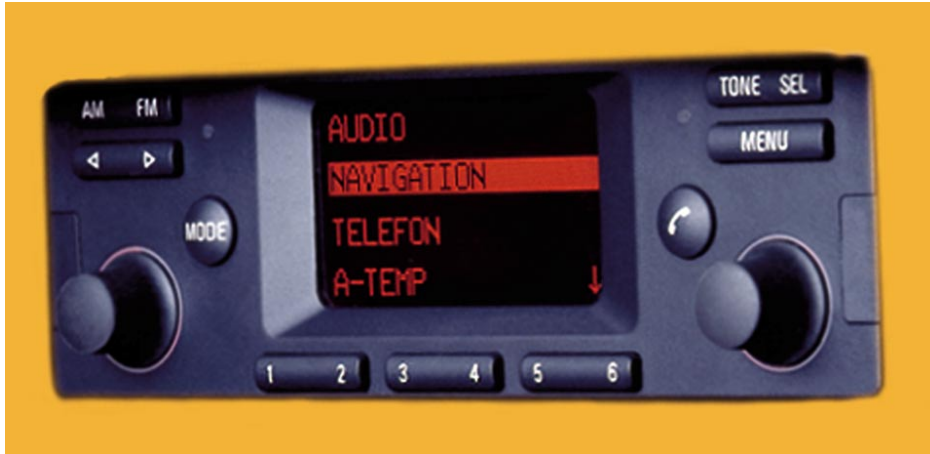

Fig. 9: Business E52 MIR NG radio

KT 5999

C53 Business BM

The radio is housed in the luggage compartment.



Fig. 10: Business NG radio operating unit (widescreen monitor, E39, E46, E53)

KT 5997

C54 Professional with CD for MID



Fig. 11: Professional NG radio with CD (E39, E53)

KT 5995



Fig. 12: Professional NG radio with CD (E39) and MID

KT 5996

C54 Professional with BM

The radio is housed in the luggage compartment.

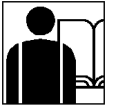

Fig. 13: Professional NG radio operating unit (widescreen monitor, E39, E46, E53)

KT 5998

Functions

NG radios



General functions

The radio functions can be activated via the operating unit and are displayed on the LC display or the BM. All system components are connected via the body/instrument bus. All button or volume control operations are conveyed to the relevant components via the body/instrument bus.

Radio operation without radio terminal

It is also possible to switch on NG radios when the radio terminal is switched off. This is not the case with BM radios.

If the radio is switched on with the radio terminal off, it will switch off again after 20 minutes. The radio can be switched on again as often as required.

Antenna diversity

There is no intermediate frequency connection on NG radios with antenna diversity (Business and Professional). The intermediate frequency is transmitted via the antenna cable (RF lead) and analysed by the diversity unit.

The diversity switches to the best possible antenna.

Antenna diversity has been adapted to the new generation of radios. When the radio is in operation, the diversity control unit is activated by the "RAD ON" signal.

World frequency radio

Specific country signals can be set using the service mode. The settings are saved in an EEPROM. The settings can be changed as often as required.

Car/key memory



The last station, the volume setting and the last audio mode (whether radio, cassette or CD mode is active) is stored according to the key. When the radio is switched on again, the volume will only be as high as the maximum start-up volume set.

The car/key memory function is deactivated by default.

Time

The time is displayed by pressing the clock symbol button, and can also be displayed when terminal R is off.

Buttons

All buttons are backlit. If a button is operated, the corresponding function is executed by the NG radio, or a message is transmitted to the body/instrument bus.

Brightness control

The light check module (LCM) and the light switch centre (LSZ) receive desired brightness information from the manual dimmer. The LCM/LSZ then processes the signal and puts the light information from the manual dimmer into operation in two ways:

- As a signal on terminal 58g
- As a message on the body/instrument bus

The light on/off signal is deduced from the body/instrument bus data.

The signal on terminal 58g is a PWM (pulse width modulated) signal. The voltage of the signal on terminal 58g is offset within the radio by the voltage from terminal 30.

The message sent to the body/instrument bus conveys only the angle of rotation of the dimmer.

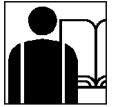
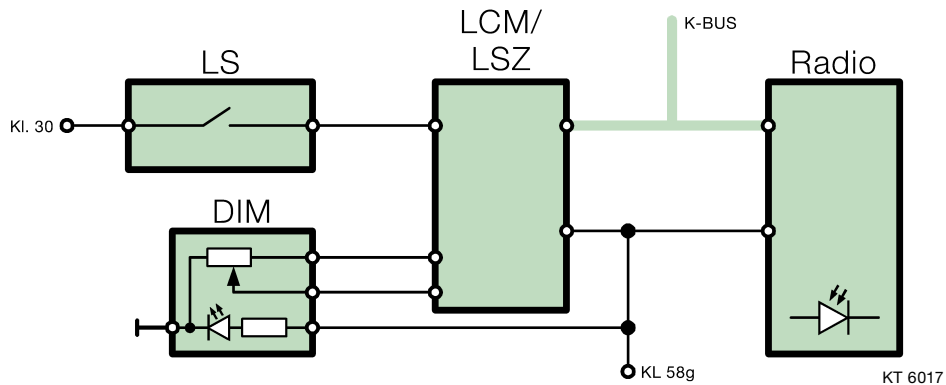

Fig. 14: Block diagram for terminal 58g

Index	Explanation	Index	Explanation
DIM	Manual dimmer	LCM/LSZ	Light check module/ light switch centre
K-Bus	Body/instrument bus	LS	Light switch
KL 58g	Terminal 58g (light on)	Radio	Radio
Kl. 30	Terminal 30 (voltage supply)		

CD changer

The radio and the CD changer are now connected by a twisted cable instead of shielded cable.

Sound control

All low frequency signals (telephone, CD etc.) are controlled through the NG radio. Source management is carried out in the NG radios.

Reset

NG radio reset is triggered by undervoltage and/or the watchdog function (internal microprocessor monitor). Reset restarts the radio. It is the equivalent of switching off the radio and then switching it on again.

Voltage monitoring



The operating voltage (battery voltage +) is measured at terminal 30.

$U_b > 17 \text{ V}$: the radio will be switched off

$U_b < 16 \text{ V}$: the radio will be switched on again

GAL (speed-sensitive volume control)

The speed signal for GAL control is made available to the radio by the body/instrument bus.

GAL control is not implemented in the radio if a DSP (digital signal processor) is fitted.

Body/instrument bus

The following information, relating to the operating unit, is distributed via the body/instrument bus:

- Request terminal status
- Terminal status
- Dimming / brightness
- Door / boot status
- Request diagnostic information (service mode)
- Diagnosis
- Request unit status
- Unit status
- On-board monitor operating unit buttons
- On-board monitor operating unit rotary knobs
- Dimming / brightness request

E46 NG radios have anti-theft devices which are linked through the body/instrument bus.

At least one further bus component must be detected before radio operation becomes possible.

Diagnostic and service notes

The instrument cluster is the gateway between the diagnostics bus and the body/instrument bus components.

MIR



System connections

The multi information radio (MIR) makes the display and operation of the following components possible as a system:

- Navigation computer
- CD changer
- Instrument cluster/BC (on-board computer) functions

Each time the radio is switched on, the MIR detects whether or not a navigation computer is fitted and displays the correct menu screen accordingly.

With navigation computer	Text and symbols are generated by the navigation computer. The data is transmitted to the MIR via the navigation bus.
Without navigation computer	Text and symbols are generated by the MIR.

On-board computer functions are not implemented on the Z8. There is no Check Control and therefore no warning of lamp failure, for example.

MIR displays the outside temperature.

Audio Mixing

Audio mixing enables the driver to listen to both music and navigation information at the same time.

Operational readiness

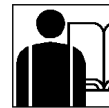

Ignition lock position 0	<p>The MIR is in sleep mode. The MENU button can be used to activate the MIR, to display the time for example. The MIR is activated when the driver's door is opened.</p> <p>The message sent to the body/instrument bus is processed once the body/instrument bus has been activated. The MENU button functions and the display heating are carried out/activated.</p> <p>The display temperature is monitored. Display heating is switched on depending on the display temperature.</p>
Ignition lock position I and/or II (radio terminal and/or terminal 15)	<p>All button and rotary knob commands are processed and executed, or conveyed to the appropriate body/instrument bus component.</p> <p>Battery voltage UB+ (terminal 30) is monitored for overvoltage/undervoltage so that the display and/or the entire MIR can be switched off if necessary. The LC display temperature monitoring device is active.</p>

LC display

The screen has a resolution of 64x120 dots (pixels). The display is backlit by LEDs.

The following factors influence the display backlighting:

- Ambient brightness (photosensor)
- Dimmer position from the body bus message (with stabilised voltage)
- Contrast (service mode)

Display heating



The display is heated to ensure the switching times of the segments reach optimum values within the shortest space of time at low temperatures. The length of time the heating is on depends on the ambient temperature. The temperature sensor is housed in the LC display.

The display heating is switched on according to the display temperature, and under the following conditions:

- The door must be opened, e.g. the driver gets in (ignition lock position 0)
- Terminal R on, body/instrument bus active
- Display on, with ignition lock position 0

MIR display heating will be switched on if the driver's door has been opened and the temperature is < approximately 15 °C.

The current status is determined by the "driver's door open/closed" data supplied by the body/instrument bus, the terminal condition (radio terminal on/off) and the body/instrument bus run-on-mode in ignition lock position 0.

If the temperature sensor is faulty (short circuit against UB+, plausibility), the heating is either not switched on, or switches off straight away.

This means that the display may take a little longer to build at low temperatures.

Time display with terminal R off

If the MENU button is pressed with ignition lock in position 0, the MIR will activate the body/instrument bus. It requests the time from the instrument cluster and displays it for 10 seconds. The MIR then returns to sleep mode.

The MIR detects the terminal status via a message from the instrument cluster.

Rotary pushbuttons (DDK)

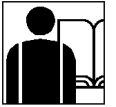

The rotary pushbuttons have a locator light.

The rotary pushbuttons are incremental and have no restriction in terms of the angle of rotation.

The radio rotary pushbutton is used for volume adjustment and for switching the radio on and off.

The radio rotary pushbutton has 36 positions per rotation.

The BM rotary pushbutton controls the system menu interface.

The BM rotary pushbutton has 16 positions per rotation.

NAV-bus (navigation bus)

The NAV-bus is a single-core bus. The same requirements exist as for the body/instrument bus (message format, baud rate etc.).

The information to be displayed is sent from the navigation computer to the MIR via the NAV-bus.

Diagnostic and service notes

The MIR has two diagnostic functions. The diagnostics differentiate between the radio and the operating unit.

BM radio



Audio Mixing

Audio mixing enables the driver to listen to both music and navigation information at the same time.

System overview

NG radio system diagram

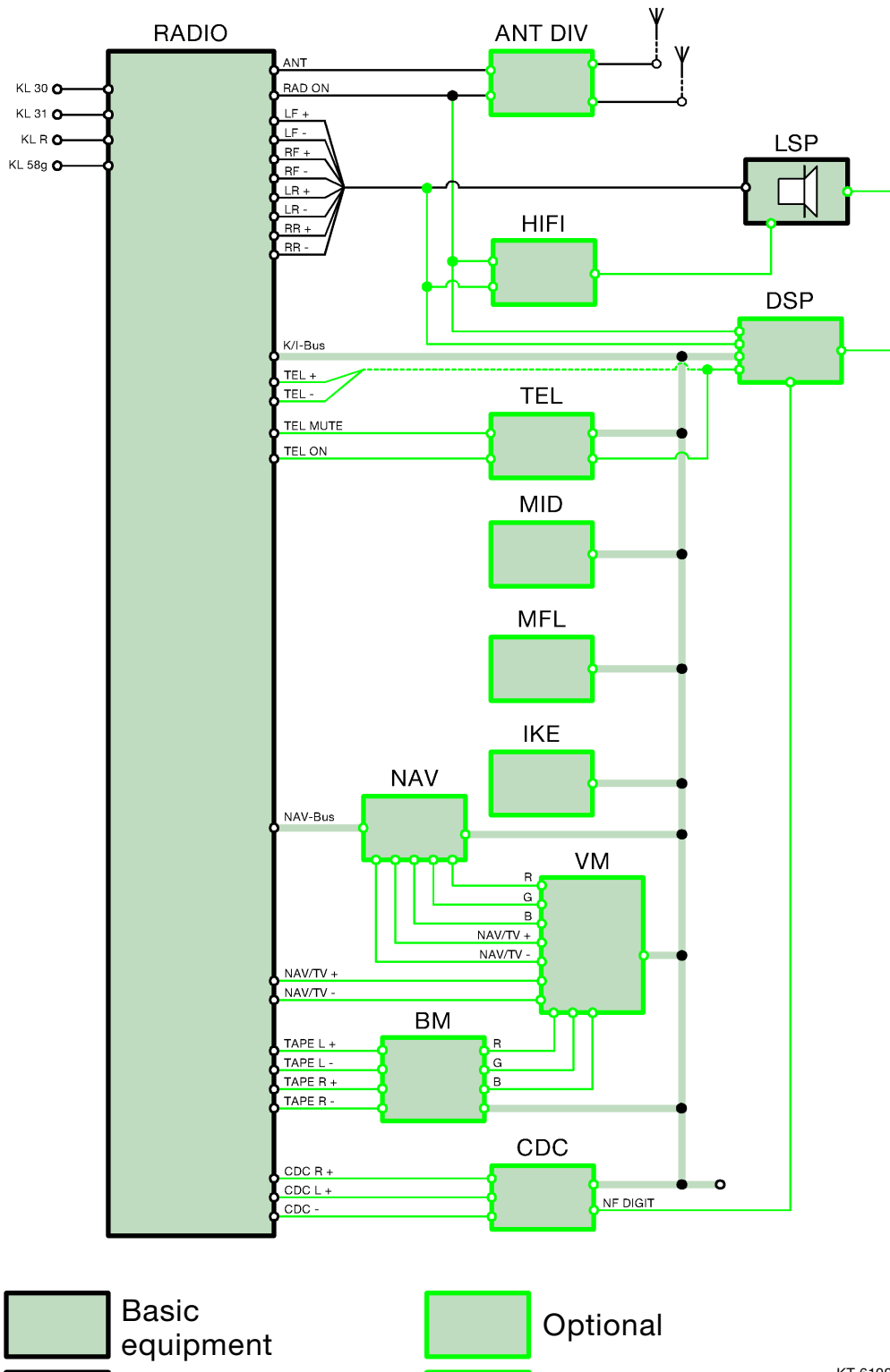
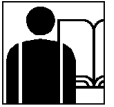

Fig. 15: Circuit diagram showing maximum equipment

KT 6109



Components

Index	Explanation	Index	Explanation
ANT DIV	Antenna diversity	LSP	Speakers
BM	On-board monitor	MFL	Multi-function steering wheel
CDC	CD changer	MID	Multi information display
DSP	Digital sound processor	NAV	Navigation computer
HEAD	Headset	RADIO	NG radio
HIFI	HIFI amplifier	TEL	Telephone
IKE	Upper instrument cluster	VM	Video module

Line descriptions

Index	Explanation	Index	Explanation
ANT	Antenna cable	NAV-Bus	Navigation bus
B	Colour information cable, blue	NAV/TV +	LF navigation/TV +
CDC R+	CD changer, right-hand channel +	NAV/TV -	LF navigation/TV -
CDC L+	CD changer, left-hand channel +	LF DIGIT	LF digital transmission
CDC -	CD changer, left/right -	R	Colour information cable, red
G	Colour information cable, green	RAD ON	Radio on signal
HEAD R+	Headset, right-hand channel +	RF +	LF output, front right +
HEAD L+	Headset, left-hand channel +	RF -	LF output, front right -
HEAD -	Headset left/right -	RR +	LF output, rear right +
K/I-Bus	Body/instrument bus	RR -	LF output, rear right -
KL 30	Terminal 30	TAPE L+	LF cassette, BM left +
KL 31	Terminal 31	TAPE L-	LF cassette, BM left -
KL R	Radio terminal	TAPE R+	LF cassette, BM right +
KL 58g	Sidelight terminal	TAPE R-	LF cassette, BM right -
LF +	LF output, front left +	TEL +	LF telephone +
LF -	LF output, front left -	TEL -	LF telephone -
LR +	LF output, rear right +	TEL MUTE	Telephone mute
LR -	LF output, rear right -	TEL ON	Telephone on signal

Test mode

Radio



Entering the service mode

Entry	Radio	Process
1	C52, C53, CD53, MD53, CD54	<ol style="list-style-type: none"> 1. Switch on the radio 2. Within 8 seconds, press and hold the m button for at least 8 seconds 3. The functions listed in the following table can then be accessed via the service menu 4. Switch the radio off to quit the service mode
2	C53 E52 MIR	<ol style="list-style-type: none"> 1. Switch on the radio 2. Within 8 seconds, press and hold the SEL button for at least 8 seconds 3. The functions listed in the following table can then be accessed via the service menu 4. Switch the radio off to quit the service mode
3	BM53, BM54	<ol style="list-style-type: none"> 1. Switch on the radio 2. Within 8 seconds, press the INFO button 3. Press and hold the BM rotary pushbutton for at least 8 seconds 4. The functions listed in the following table can then be accessed via the service menu 5. Switch the radio off to quit the service mode

Test mode table



Menu	Screen contents	Explanation
Serial Number	e.g. X1001035	Radio serial number
Software Version	e.g. 37-99 30	Radio software version (calendar week 37, 1999, version 3.0)
GAL	e.g. 3	The speed-sensitive volume control level can be adjusted from 1 to 6 using station buttons 1 to 6
FM	Frequency ...	The frequency of the station currently being received
	Station identifier ...	Station identifier of station currently being received
	F ...	Signal strength of the station currently being received
	Q ...	Quality of the station currently being received
	e.g. D210	RDS identifier of the station currently being received
DSP	0	Information about whether DSP is available; DSP is fitted for display 1, the information is conveyed to the radio via the body/instrument bus
TP volume	e.g. 0	Setting the traffic reports minimum volume within the range of -9 to +9, using station buttons 1 and 2
AF	e.g. AUTO	The appropriate AF tracking can be set using station buttons 1 to 4 1 = RDS OFF 2 = AF OFF (RDS on, AF off) 3 = AF MAN (RDS on, AF manual) 4 = AF AUTO (RDS on, AF automatic)
Area	e.g. Europe	The appropriate country variants can be set using station buttons 1 to 5 1 = Europe 2 = USA 3 = Japan 4 = Oceania 5 = Canada
Index	e.g. 03	Revision index, e.g. 03

More detailed information about the individual screen contents can be found in Part 1 of the test mode brochure

Navigation



Entering the service mode

Entry	Control panel	Process
1	C53 E52 MIR	<ol style="list-style-type: none"> 1. Switch on the MIR 2. Press and hold the "SEL" button for at least 8 seconds 3. Switch off the radio terminal or switch the radio off and on again to quit the service mode
2	BM53, BM54	<ol style="list-style-type: none"> 1. Switch on the on-board monitor 2. Change to the "Set" menu item 3. Press and hold the "MENU" button for at least 8 seconds 4. Switch off the radio terminal to quit the service mode

Test mode table

Menu	Submenu	Screen contents
Control panel	Version	SW-flash SW-slave HW-status Diag-index Bus-index Coding index Supplier
	Function of keys	Key Contr. button Radio control
	Brightness contr.	-----▲-----
	Test display	Various patterns
Navigation/ graphic element		SW-status HW-status Diag-index Bus-index Coding index Supplier

Menu	Submenu	Screen contents
GPS	Version	Receiver SW date
	Status	Latitude Longitude Altitude Date Time G speed Heading Rec-Stat Pos-Src PDOP HDOP VDOP
	Tracking Info	CH PRN S/N Visible Sat Almanac
Video module		SW-status HW-status Diag-index Bus-index Coding index Supplier
Sensor check		Wheel Satellites GPS status Gyro Dir
Telematics		VIN Vehicle type Colour Reg. number SMS code number D1 BMW information Automatic emergency call Initialization Sign-off



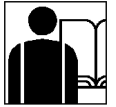

Menu	Monitor contents	Explanation
Operating unit	SW-flash SW-slave HW-status Diag-index Bus-index Coding index Supplier Key Contr. button Radio control -----▲▼-----	Software version in flash memory Software version in slave Hardware version Diagnostics detection index Bus detection index Coding detection index Manufacturer's key number Number display for buttons Hexadecimal rotary pushbutton display The function is quit 5 seconds after a button was last pressed Hexadecimal rotary pushbutton display See Contr. button Arrow display for the value set
GPS/Status	G speed Heading Rec-Stat Pos-Src PDOP HDOP VDOP	Relative vehicle speed over the ground Direction of travel Search/track/position receiver status Number of satellites available for analysis Accuracy of the calculated position < 8 sufficient determinations of position < 4 very good determinations of position
GPS/Tracking info	CH PRN S/N Visible Sat Almanac	Channel Satellite detection The better the reception the higher the value The number of visible satellites, signals receivable, depends on time of day and constellation Satellite database, automatically loaded after 15 minutes
Sensor check	Wheel Satellites GPS status Gyro Dir	ABS sensors, pulses/minute, negative when reversing Number of satellites currently received 07: 3 Sat, position possible; 11: 2D-position determined; 12: 3D-position determined +- 400; mV setpoint value, halted or driving straight ahead, > right-hand, < left-hand curve Reverse gear signal detection Backward: reverse gear selected
Telematics	VIN Colour D1 BMW information Automatic emergency call Initialization Sign-off	Vehicle identification number Colour code or text Telephone network/contract number Customer-specific information Status on/off Telematics service status on/off Log out of the telematics service

- PDOP Position Dilution of Precision
- HDOP Horizontal Dilution of Precision
- VDOP Vertical Dilution of Precision
- S/N Signal/noise ratio
- Gyro Piezo Gyro sensor (in navigation computer)
- Dir Direction of travel

NG radio connector pinouts

E46 radio connector pinouts

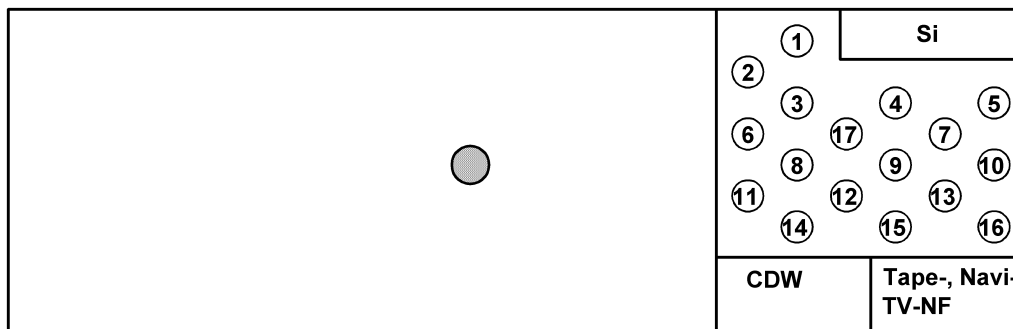
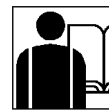

Fig. 16: Back of the radio showing the old connector pinouts (Si = fuse)

KT 6105

Upper section

Index	Explanation	Index	Explanation
1	LF output, front left +	10	TEL ON (telephone on)
2	LF output, front right +	11	LF output, front right +
3	LF output, rear left +	12	LF output, rear left -
4	Telephone mute	13	Terminal 58g
5	Radio terminal	14	LF output, rear right -
6	LF output, rear right +	15	Terminal 31
7	Body/instrument bus connection	16	Antenna + amplifier switching signal
8	LF output, front left -	17	Instrument cluster control signal (not used)
9	Terminal 30		

Left lower section (CD changer)

Index	Explanation	Index	Explanation
1	LF CD L +	6	LF CD L -
2	LF CD R +	7	LF CD R -
3	LF telephone-	8	LF telephone+
4	Blank	9	Blank
5	Blank	10	Blank

Right lower section (tape, navigation and TV-LF)

Index	Explanation	Index	Explanation
1	LF cassette tray, right +	6	LF cassette tray, left +
2	LF cassette tray, right -	7	LF cassette tray, left -
3	Navigation bus (MIR)	8	Blank
4	Blank	9	Blank
5	LF navigation/TV -	10	LF navigation/TV +

E39, E52, E53 radio connector pinouts

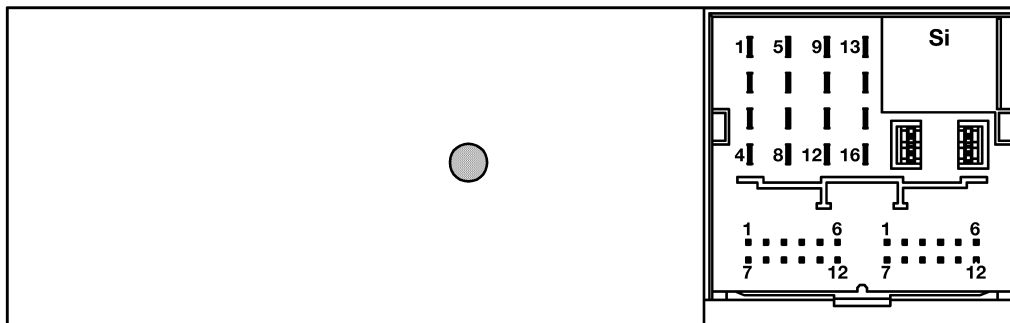
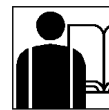

KT 6106

Fig. 17: Back of the radio showing the new connector pinouts (Si = fuse)

Upper section

Index	Explanation	Index	Explanation
1	LF output, rear right +	9	Body/instrument bus connection
2	LF output, front right +	10	Telephone mute
3	LF output, front left +	11	Telephone on signal
4	LF output, rear left +	12	Terminal 31
5	LF output, rear right -	13	Antenna and amplifier switching signal
6	LF output, front right -	14	Terminal 58g
7	LF output, front left -	15	Terminal 30
8	LF output, rear left -	16	Radio terminal

Left lower section

Index	Explanation	Index	Explanation
1	Not used	7	Not used
2	LF CD changer -	8	LF CD changer, left +
3	Not used	9	LF CD changer, right +
4	LF VCR, right +	10	LF TV, right +
5	LF VCR, left +	11	LF TV, left +
6	LF VCR -	12	LF TV -

Right lower section

Index	Explanation	Index	Explanation
1	LF tape, left +	7	LF tape, right +
2	LF tape, left -	8	LF tape, right -
3	Not used	9	Navigation bus
4	Not used	10	Not used
5	Navigation/LF TV +	11	Navigation/TV -
6	Telephone +	12	Telephone -

Abbreviations

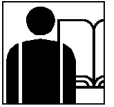

Index	Explanation
AUX	Audio source
BC	On-board computer
BM	On-board monitor
BM Radio	On-board monitor radio
CD	Compact Disk
DDK	Rotary pushbutton
DSP	Digital sound processor
GAL	Speed-sensitive volume control
HF	High frequency
Kl. 58g	Sidelight terminal
Kl. 30	Permanent positive terminal
I-Bus	Information bus
K-Bus	Body bus
Kl. R	Radio terminal
LC Display	Liquid Crystal Display
LCM	Light check module
LSZ	Light switch centre
LED	Light Emitting Diode
MD	Mini Disc
MID	Multi information display
MIR	Multi information radio
MMC	Multi media changer
NAV-Bus	Navigation bus
NF	Low frequency
NG Radio	New Generation Radio
PWM	Pulse width modulated
RAD ON	Radio on (signal description)
SA	Optional extra
SE	Series launch
SW	Software
TV	Television
UB+	Battery voltage
VCR	Video Cassette Recording
WS	Widescreen
ZF	Intermediate frequency