

AX

REMOVAL

1. DISCONNECT CABLE FROM NEGATIVE BATTERY TERMINAL

CAUTION:

Wait at least 90 seconds after disconnecting the cable from the negative (-) battery terminal to prevent airbag and seat belt pretensioner activation.

2. REMOVE NO. 1 ENGINE UNDER COVER

3. DRAIN AUTOMATIC TRANSAXLE FLUID

- (a) Remove the drain plug and gasket, and drain ATF.
- (b) Install a new gasket and the drain plug.

Torque: 47 N*m (479 kgf*cm, 35 ft.*lbf)

4. REMOVE AUTOMATIC TRANSAXLE OIL PAN SUB-ASSEMBLY

- (a) Remove the 18 bolts, oil pan and gasket.

NOTICE:

Some fluid will remain in the oil pan. Carefully remove the oil pan sub-assembly.

- (b) Remove the 3 magnets from the oil pan.

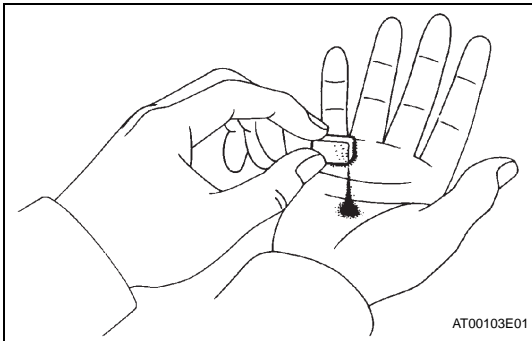
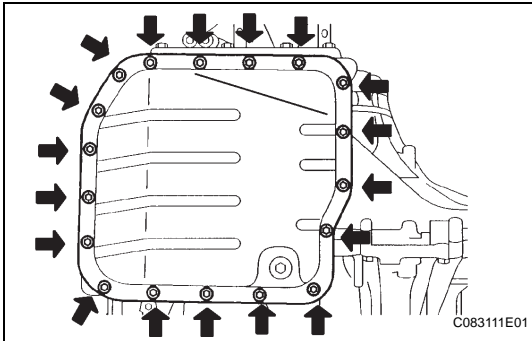

- (c) Examine particles in the pan.

- (1) Use the removed magnets to collect any steel chips. Look carefully at the chips and particles in the pan and on the magnet to anticipate what type of wear you will find in the transaxle.
Steel (magnetic): bearing, gear and plate wear
Brass (non-magnetic): bush wear

5. REMOVE VALVE BODY OIL STRAINER ASSEMBLY

- (a) Remove the 3 bolts and oil strainer.

NOTICE:

Be careful as some fluid will come out with the oil strainer.

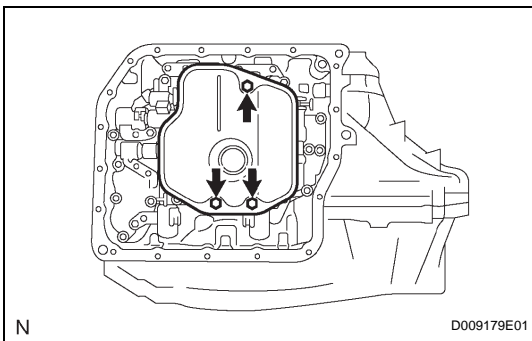

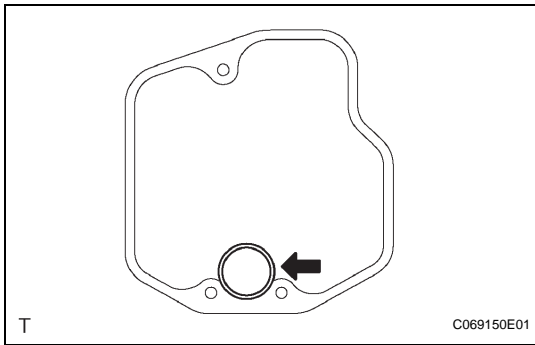

(b) Remove the O-ring from the oil strainer.

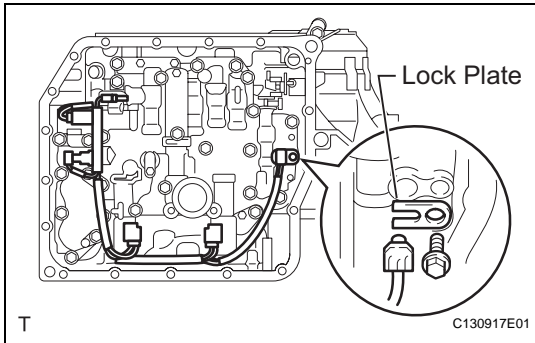

6. DISCONNECT TRANSMISSION WIRE

- (a) Disconnect the 5 connectors.
- (b) Remove the bolt and lock plate, and remove the ATF temperature sensor.

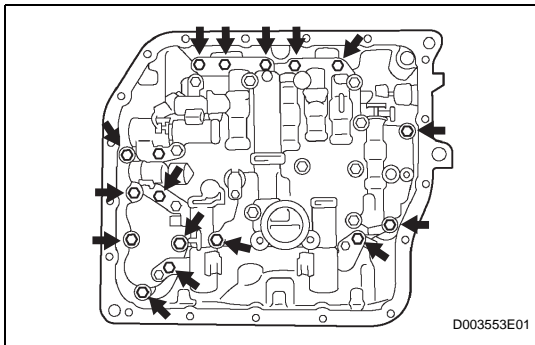

7. REMOVE TRANSMISSION VALVE BODY ASSEMBLY

- (a) Support the valve body and remove the 17 bolts and valve body.

NOTICE:

Be careful not to drop the check valve body, spring and accumulator piston.

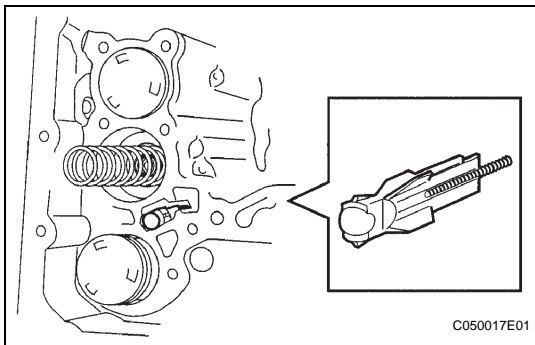

- (b) Remove the check ball body and spring.

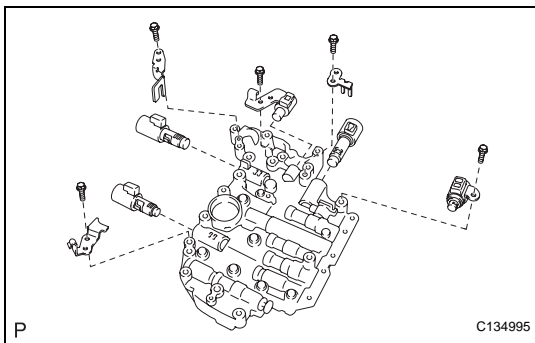

- (c) Remove the 5 bolts, 4 plates and 5 shift solenoid valves.