

DIRECT CLUTCH

COMPONENTS

AX

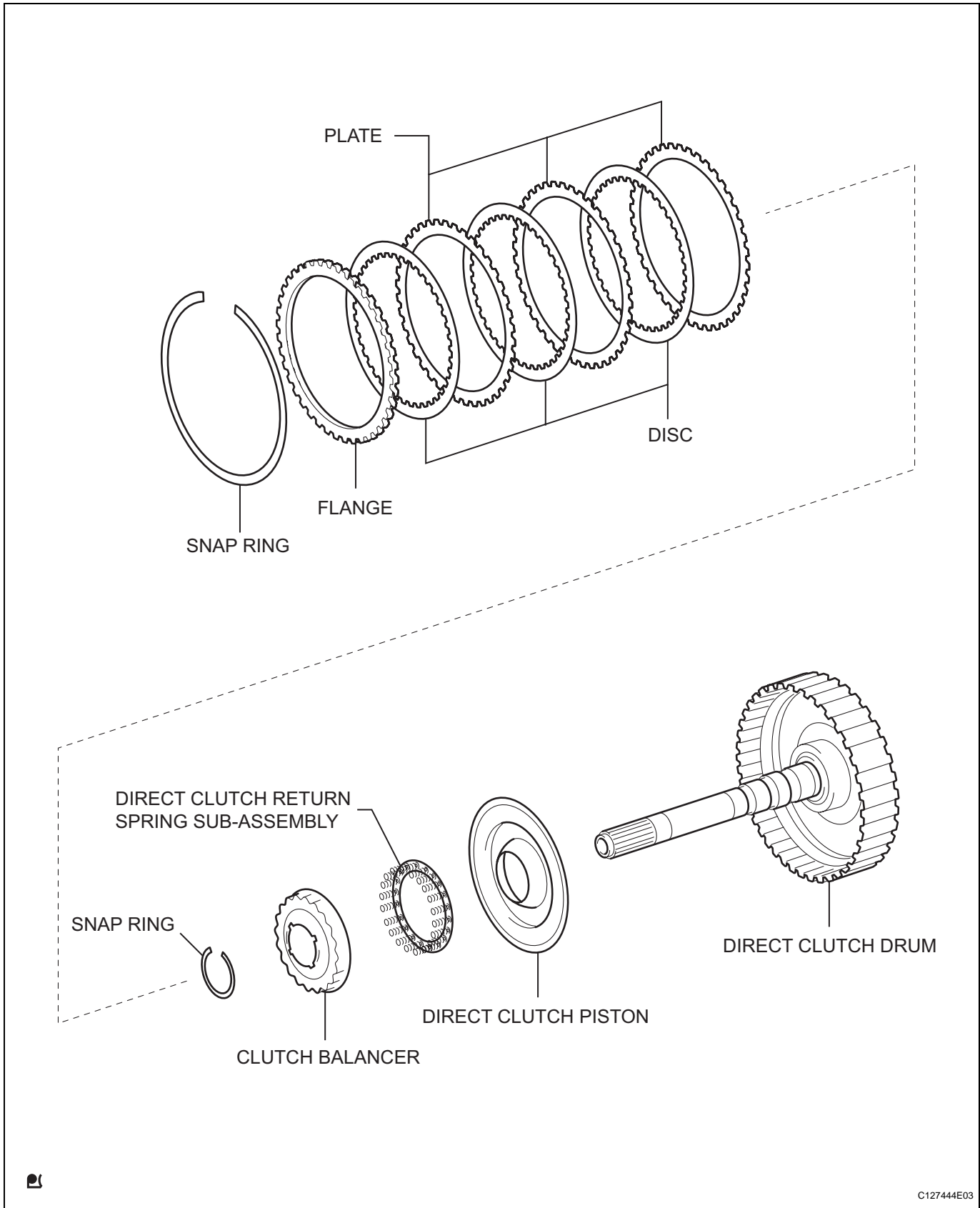

DISASSEMBLY

1. INSPECT PACK CLEARANCE OF DIRECT CLUTCH (See page AX-234)

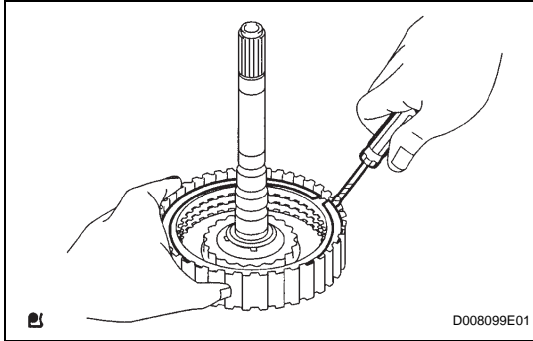

2. REMOVE DIRECT MULTIPLE DISC CLUTCH DISC

- (a) Using a screwdriver, pry out the snap ring from the direct clutch drum.

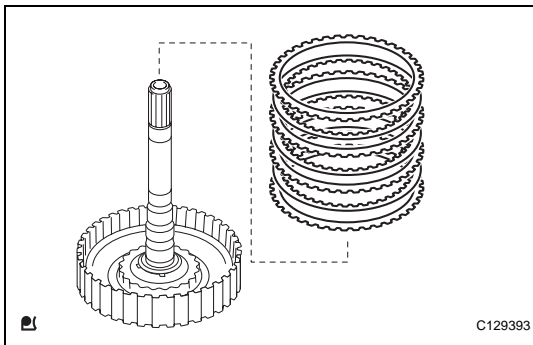

- (b) Remove the flange, 3 discs and 3 plates from the direct clutch drum.

3. INSPECT DIRECT MULTIPLE DISC CLUTCH DISC (See page AX-234)

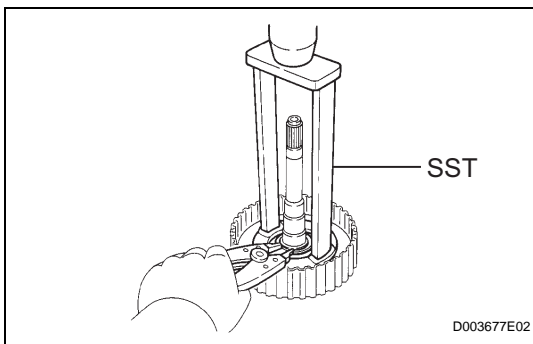

4. REMOVE DIRECT CLUTCH RETURN SPRING SUB-ASSEMBLY

- (a) Place SST on the clutch balancer and compress the spring with a press.

SST 09387-00020

- (b) Using a snap ring expander, remove the snap ring from the direct clutch drum.

HINT:

- Stop the press when the spring sheet is lowered to the place 1 to 2 mm (0.039 to 0.078 in.) from the snap ring groove.
- This prevents the spring sheet from being deformed.
- Do not expand the snap ring excessively.

- (c) Remove the clutch balancer from the direct clutch drum.

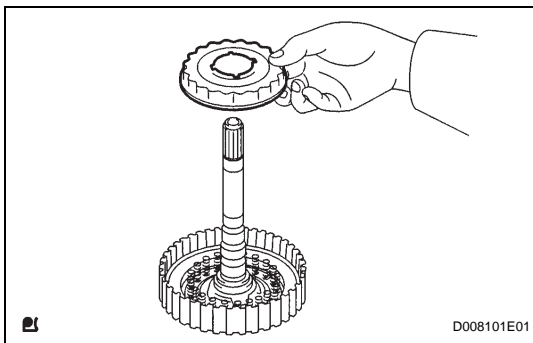

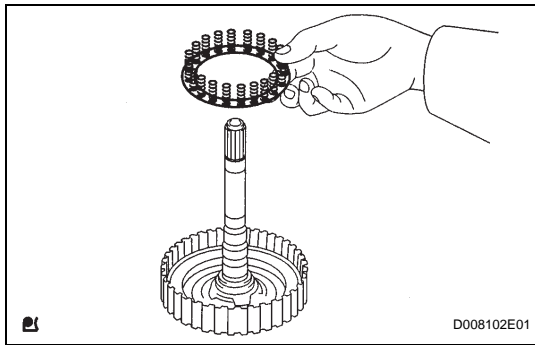

- (d) Remove the piston return spring from the direct clutch drum.

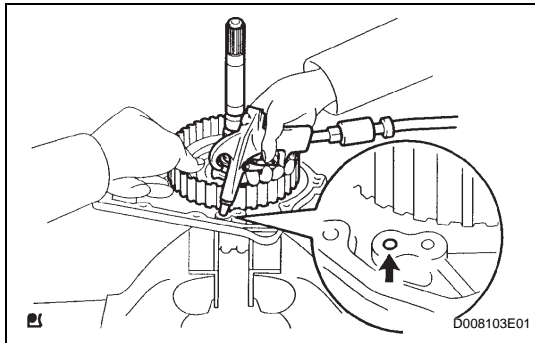

- (e) Install the direct clutch drum on the transaxle rear cover.
 (f) Holding the direct clutch piston with your hand, apply compressed air (392 kPa, 4.0 kgf/cm², 57 psi) to the transaxle rear cover to remove the direct clutch piston.

5. INSPECT DIRECT CLUTCH RETURN SPRING SUB-ASSEMBLY (See page AX-235)

INSPECTION

1. INSPECT PACK CLEARANCE OF DIRECT CLUTCH

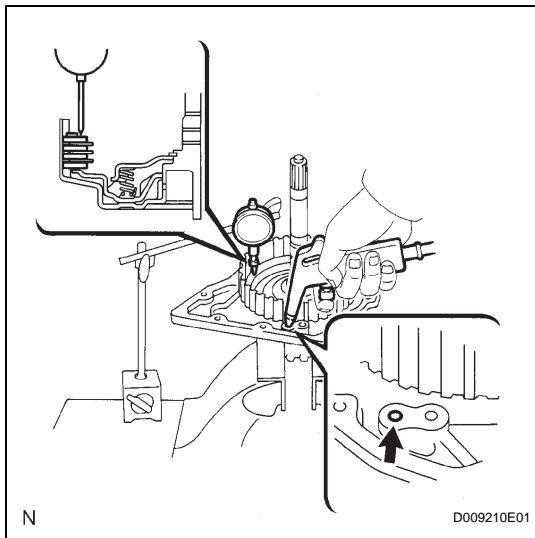

- (a) Install the direct clutch and needle roller bearing on the transaxle rear cover.
 (b) Using a dial indicator, measure the direct clutch pack clearance while applying and releasing compressed air (392 kPa, 4.0 kgf/cm², 57 psi).

Standard pack clearance:

0.605 to 0.825 mm (0.0238 to 0.0325 in.)

If the pack clearance is not as specified, inspect the discs, plates and flange.

2. INSPECT DIRECT MULTIPLE DISC CLUTCH DISC

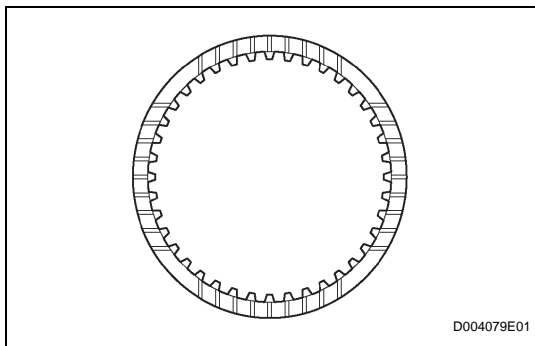

- (a) Check to see if the sliding surface of the disc, plate and flange are worn or burnt. If necessary, replace them.

HINT:

- If the lining of the disc is peeling off or discolored, or even if a part of the printed mark is defaced, replace all discs.
- Before assembling new discs, soak them in ATF for at least 15 minutes.

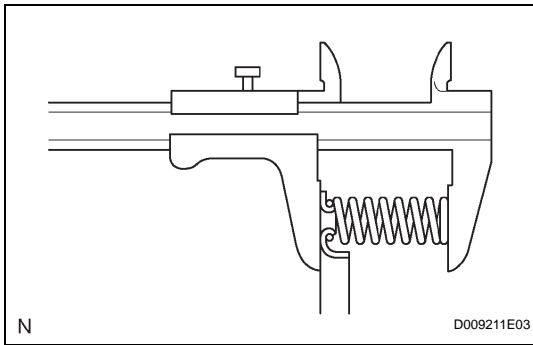

3. INSPECT DIRECT CLUTCH RETURN SPRING SUB-ASSEMBLY

- (a) Using a vernier caliper, measure the free length of the spring together with the spring seat.

Standard free length:
22.58 mm (0.8890 in.)

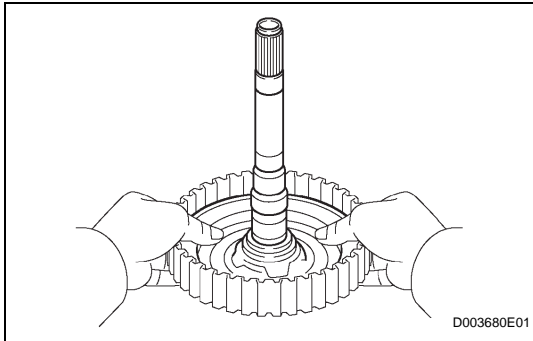

REASSEMBLY

1. INSTALL DIRECT CLUTCH RETURN SPRING SUB-ASSEMBLY

- (a) Coat the direct clutch piston with ATF, and install it to the direct clutch drum.

NOTICE:

Be careful not to damage the lip seal of the direct clutch piston.

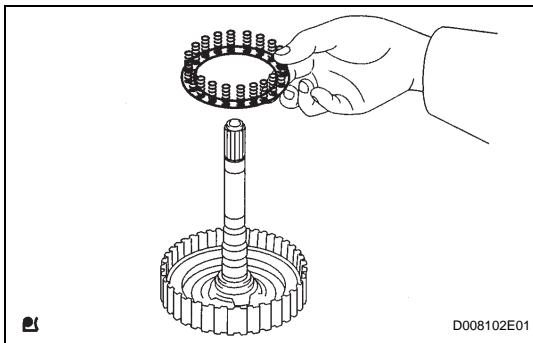

- (b) Install the piston return spring to the direct clutch drum.

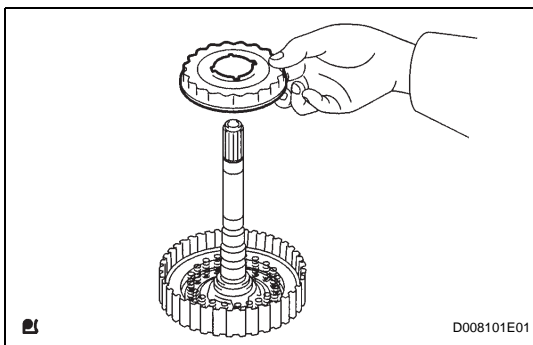

- (c) Install the clutch balancer to the direct clutch drum.

NOTICE:

Be careful not to damage the lip seal of the direct clutch balancer.

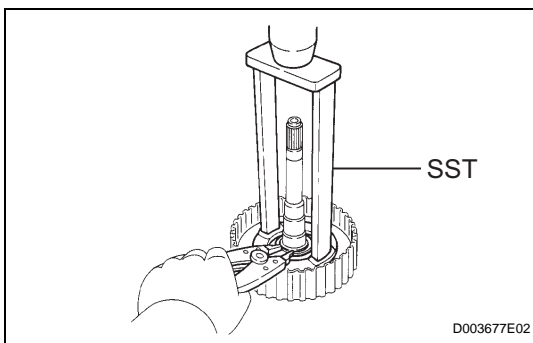

- (d) Place SST on the clutch balancer and compress the piston return spring with a press.

SST 09387-00020

- (e) Using a snap ring expander, install the snap ring to the direct clutch drum.

NOTICE:

- **Be sure the end gap of the snap ring is not aligned with the clutch balancer claw.**
- **Stop the press when the spring sheet is lowered to the place 1 to 2 mm (0.039 to 0.078 in.) from the snap ring groove.**

AX

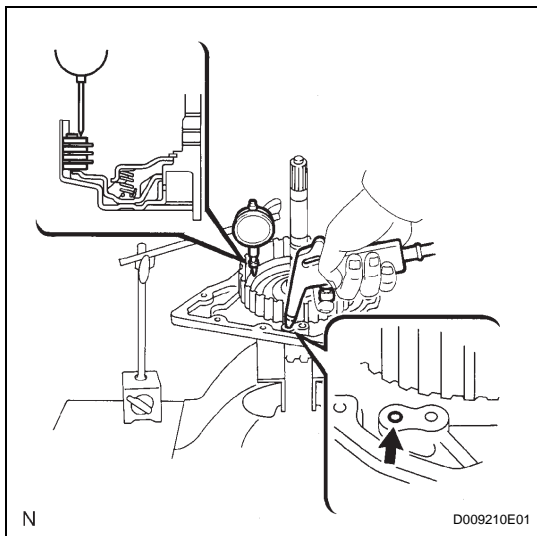
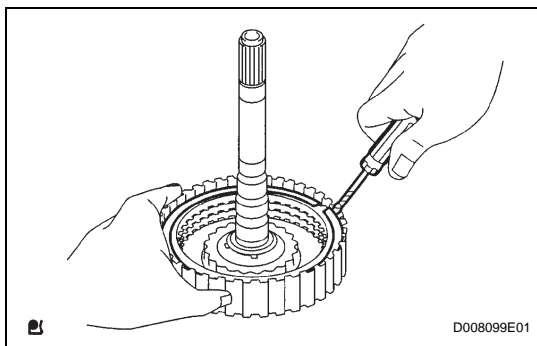
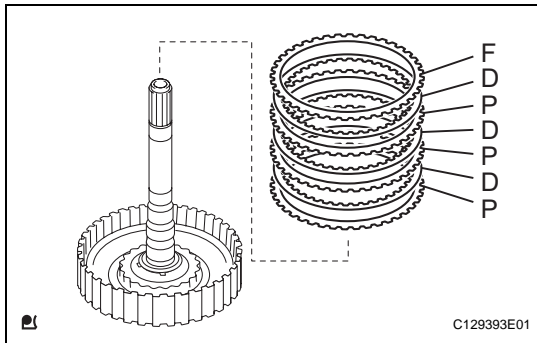

- This prevents the spring sheet from being deformed.
- Do not expand the snap ring excessively.

2. INSTALL DIRECT MULTIPLE DISC CLUTCH DISC

(a) Install the 3 plates, 3 discs and flange.

Install in order:

P - D - P - D - P - D - F

HINT:

P = Plate

D = Disc

F = Flange

(b) Using a screwdriver, install the snap ring.

(c) Check that the end gap of the snap ring is not aligned with one of the cutouts.

3. INSPECT PACK CLEARANCE OF DIRECT CLUTCH

(a) Install the direct clutch on the transaxle rear cover.

(b) Using a dial indicator, measure the direct clutch pack clearance while applying and releasing compressed air (392 kPa, 4.0 kgf/cm², 57 psi).

Standard pack clearance:

0.605 to 0.825 mm (0.02382 to 0.03248 in.)

If the pack clearance is less than the minimum, parts may have been assembled incorrectly, so check and reassemble again.

If the stroke is not as specified, select another flange.

HINT:

There are 6 flanges in different thickness.

Standard flange thickness

No.	Thickness	No.	Thickness
1	3.0 mm (0.118 in.)	4	3.3 mm (0.130 in.)
2	3.1 mm (0.122 in.)	5	3.4 mm (0.134 in.)
3	3.2 mm (0.126 in.)	6	3.5 mm (0.138 in.)

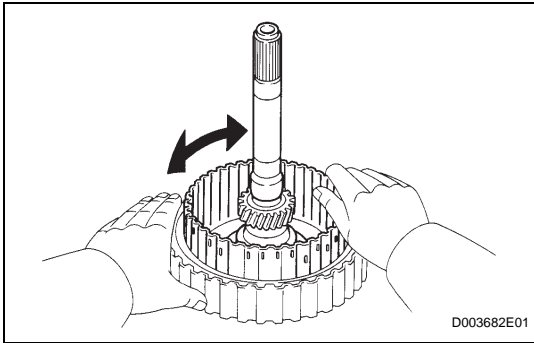

4. INSPECT DIRECT MULTIPLE DISC CLUTCH CLUTCH DISC

- (a) Inspect the clutch disc rotation.
- (1) Check that the disc rotates when rotating the disc after inserting the rear planetary sun gear.

NOTICE:

Do not place the rear planetary sun gear in a vise.