

TRANSMISSION CONTROL CABLE ASSEMBLY

REPLACEMENT

AX

1. **REMOVE REAR CONSOLE BOX SUB-ASSEMBLY**
 - (a) Remove the console box (see page IP-20).
2. **DISCONNECT CABLE FROM NEGATIVE BATTERY TERMINAL**
CAUTION:
Wait at least 90 seconds after disconnecting the cable from the negative (-) battery terminal to prevent airbag and seat belt pretensioner activation.
3. **REMOVE BATTERY**
 - (a) Loosen the nut and remove the bolt and battery clamp.
 - (b) Remove the battery and insulator.
 - (c) Remove the battery tray.
 - (d) Remove the 4 bolts and battery carrier.
 - (e) Remove the 2 bolts and battery bracket reinforcement.
4. **REMOVE AIR CLEANER ASSEMBLY**
 - (a) Disconnect the mass air flow meter connector.
 - (b) Disconnect the VSV connector.
 - (c) Disconnect the wire harness clamp and 3 vacuum hoses.
 - (d) Disconnect the No. 2 ventilation hose from the air cleaner hose.
 - (e) Loosen the No. 1 air cleaner hose clamp.
 - (f) Unfasten the 2 hook clamps, and then remove the air cleaner cap.
 - (g) Remove the air cleaner filter element from the air cleaner case.
 - (h) Disconnect the harness clamp.
 - (i) Remove the 3 bolts and air cleaner case.
5. **REMOVE TRANSAXLE CONTROL CABLE ASSEMBLY**
 - (a) Remove the nut and disconnect the control cable from the control shaft lever.

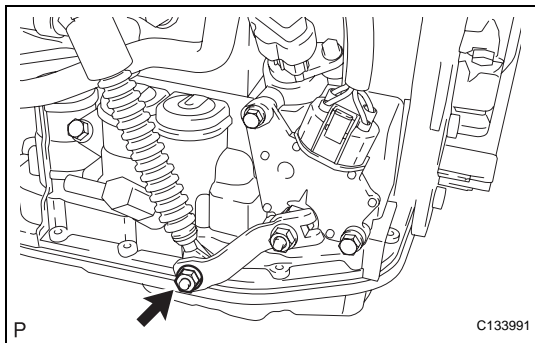

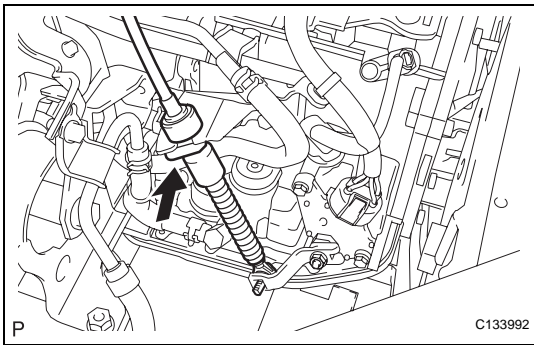

- (b) Remove the clip and disconnect the control cable from the control cable bracket.

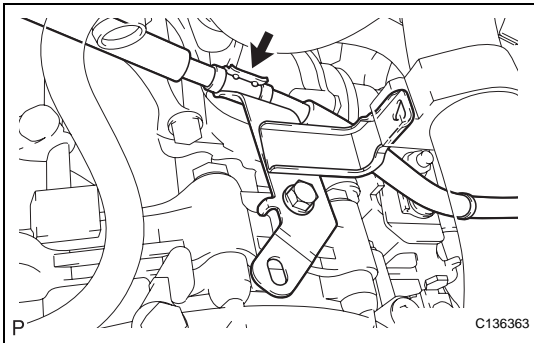

- (c) Disconnect the control cable from the control cable support.

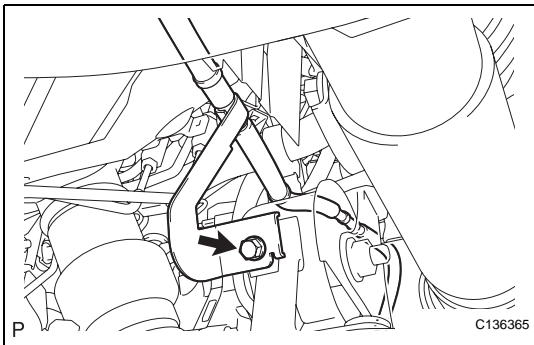

- (d) Remove the bolt and disconnect the clamp of the control cable.

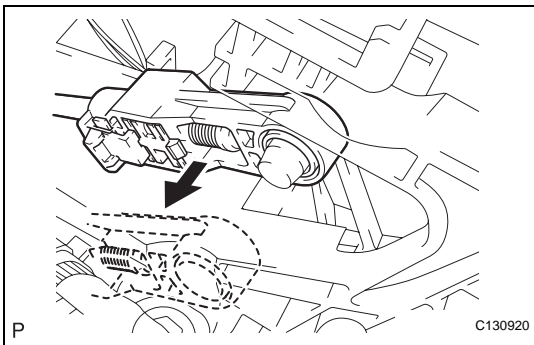

- (e) Disconnect the control cable from the shift lever.

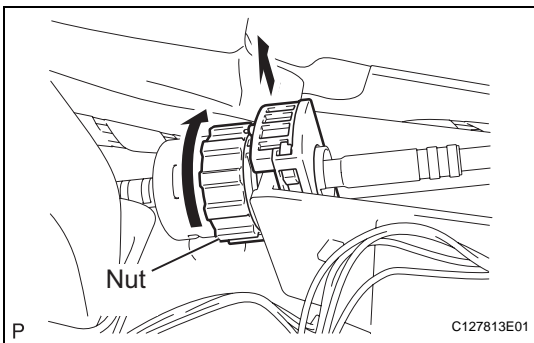

- (f) Turn the nut and disconnect the control cable from the shift lever retainer.

AX

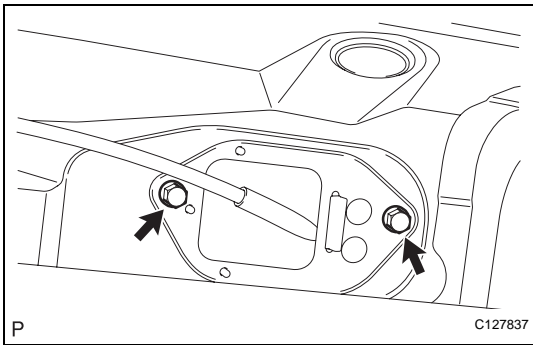

(g) Remove the 2 bolts and control cable.

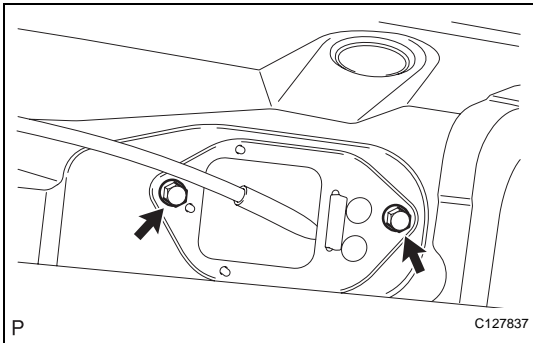

6. INSTALL TRANSAXLE CONTROL CABLE ASSEMBLY

(a) Install the control cable with the 2 bolts.
Torque: 5.0 N*m (51 kgf*cm, 44 in.*lbf)

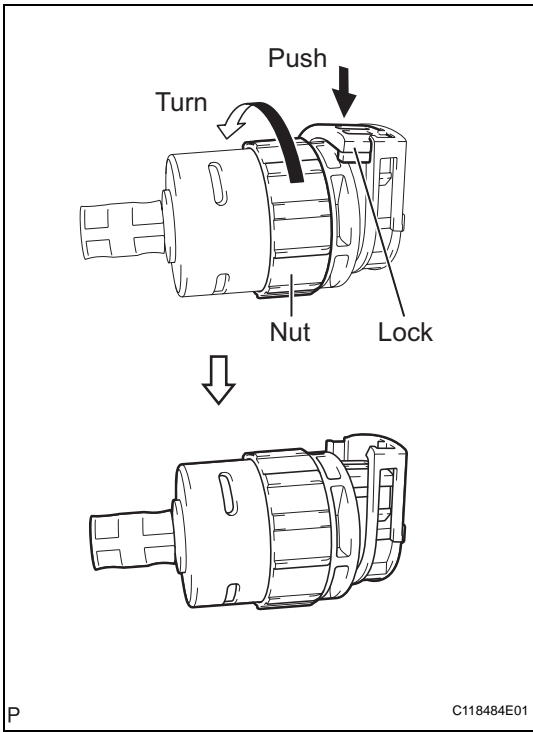

(b) Turn the nut of the control cable and push in the lock.

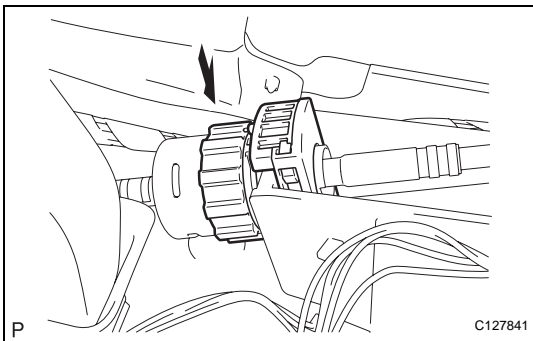

(c) Install the control cable onto the shift lever retainer.

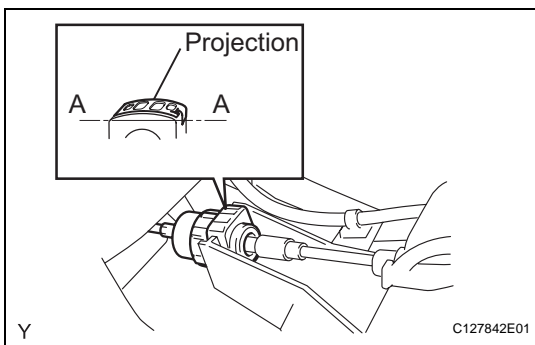
**NOTICE:**

- Install the cable with the protruding portion of the cable outer facing upward.
- After installing, check that the lock of the cable outer is protruding beyond portion A-A, as shown in the illustration.

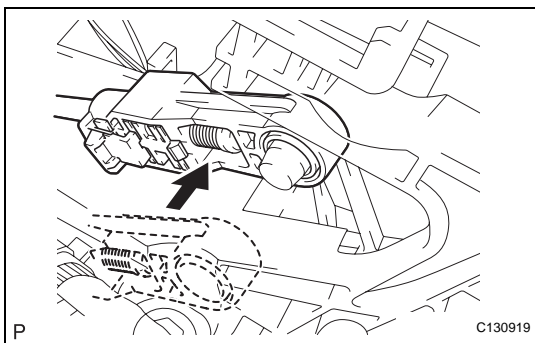

- (d) Connect the control cable to the shift lever.

NOTICE:

Connect the control cable so that the adjusting mechanism lock of the control cable is installed on the driver side of the vehicle.

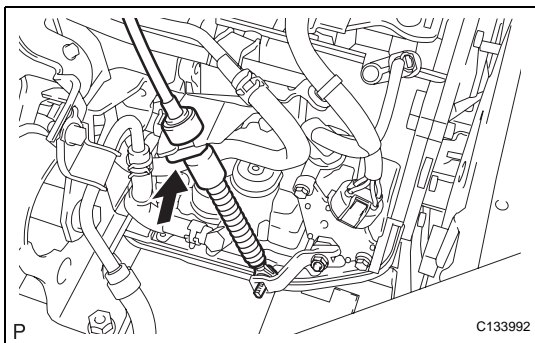

- (e) Fix the control cable onto the control cable bracket with the clip.

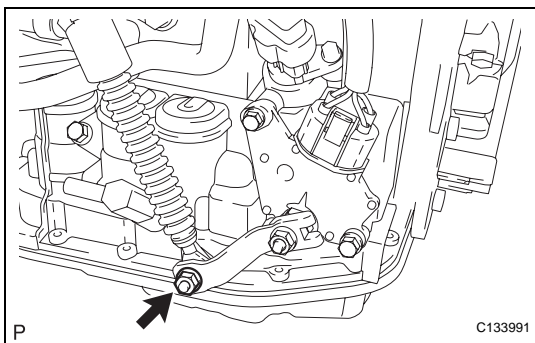

- (f) Connect the control cable onto the control shaft lever with the nut.
Torque: 12 N*m (122 kgf*cm, 9 ft.*lbf)

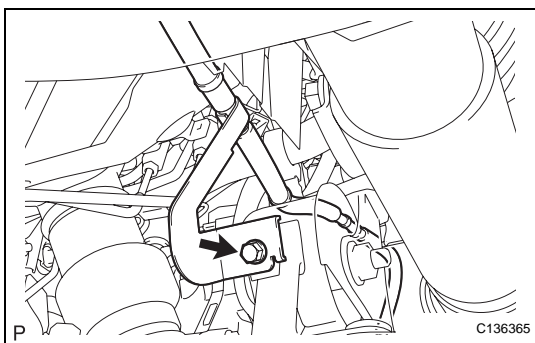

- (g) Connect the clamp of the control cable with the bolt.
Torque: 15 N*m (153 kgf*cm, 11 ft.*lbf)

AX

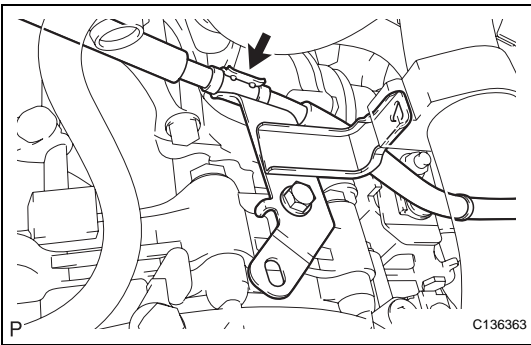

(h) Connect the control cable to the cable support.

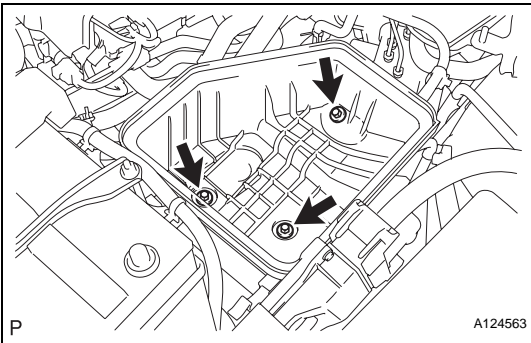

7. INSTALL AIR CLEANER ASSEMBLY

(a) Install the air cleaner case with the 3 bolts.

Torque: 5.0 N*m (51 kgf*cm, 44 in.*lbf)

(b) Connect the harness clamp.

(c) Install the air cleaner filter element onto the air cleaner case.

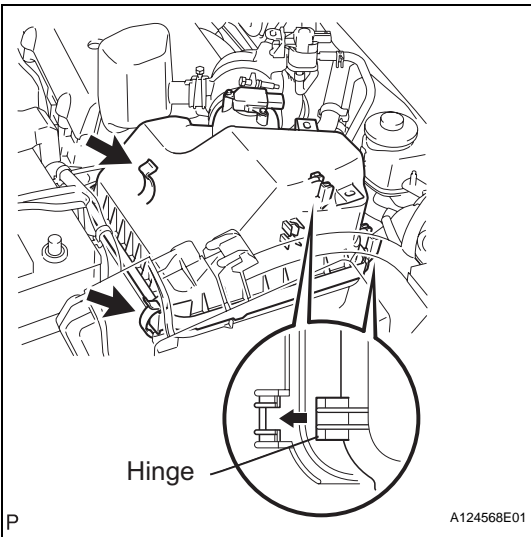

(d) Insert the hinge part of the air cleaner cap into the air cleaner case, then hang the 2 hook clamps.

(e) Tighten the No. 1 air cleaner hose clamp.

(f) Connect the No. 2 ventilation hose to the air cleaner hose.

(g) Connect the wire harness clamp and 3 vacuum hoses.

(h) Connect the VSV connector.

(i) Connect the mass air flow meter connector.

8. INSTALL BATTERY

(a) Install the battery bracket reinforcement with the 2 bolts.

Torque: 20 N*m (204 kgf*cm, 15 ft.*lbf)

(b) Install the battery carrier with the 4 bolts.

Torque: 20 N*m (204 kgf*cm, 15 ft.*lbf)

(c) Install the battery tray.

(d) Connect the 2 clamps of the engine wire.

(e) Install the battery and insulator with the battery clamp.

**Torque: 8.5 N*m (87 kgf*cm, 75 in.*lbf) for bolt
5.0 N*m (51 kgf*cm, 44 in.*lbf) for nut**

9. CONNECT CABLE TO NEGATIVE BATTERY TERMINAL

10. INSPECT SHIFT LEVER POSITION

(a) When shifting the lever from P to the R position with the ignition switch ON and the brake pedal depressed, make sure that the shift lever moves smoothly and moves correctly into position.

- (b) Start the engine and make sure that the vehicle moves forward when shifting the lever from N to the D position and moves rearward when shifting the lever to the R position.

If the operation cannot be performed as specified, inspect the park/neutral position switch and check the shift lever installation condition.

- 11. ADJUST SHIFT LEVER POSITION (See page [AX-164](#))**
- 12. INSTALL REAR CONSOLE BOX SUB-ASSEMBLY**
 - (a) Install the rear console box (see page [IP-26](#)).

AX