

FORWARD CLUTCH

COMPONENTS

AX

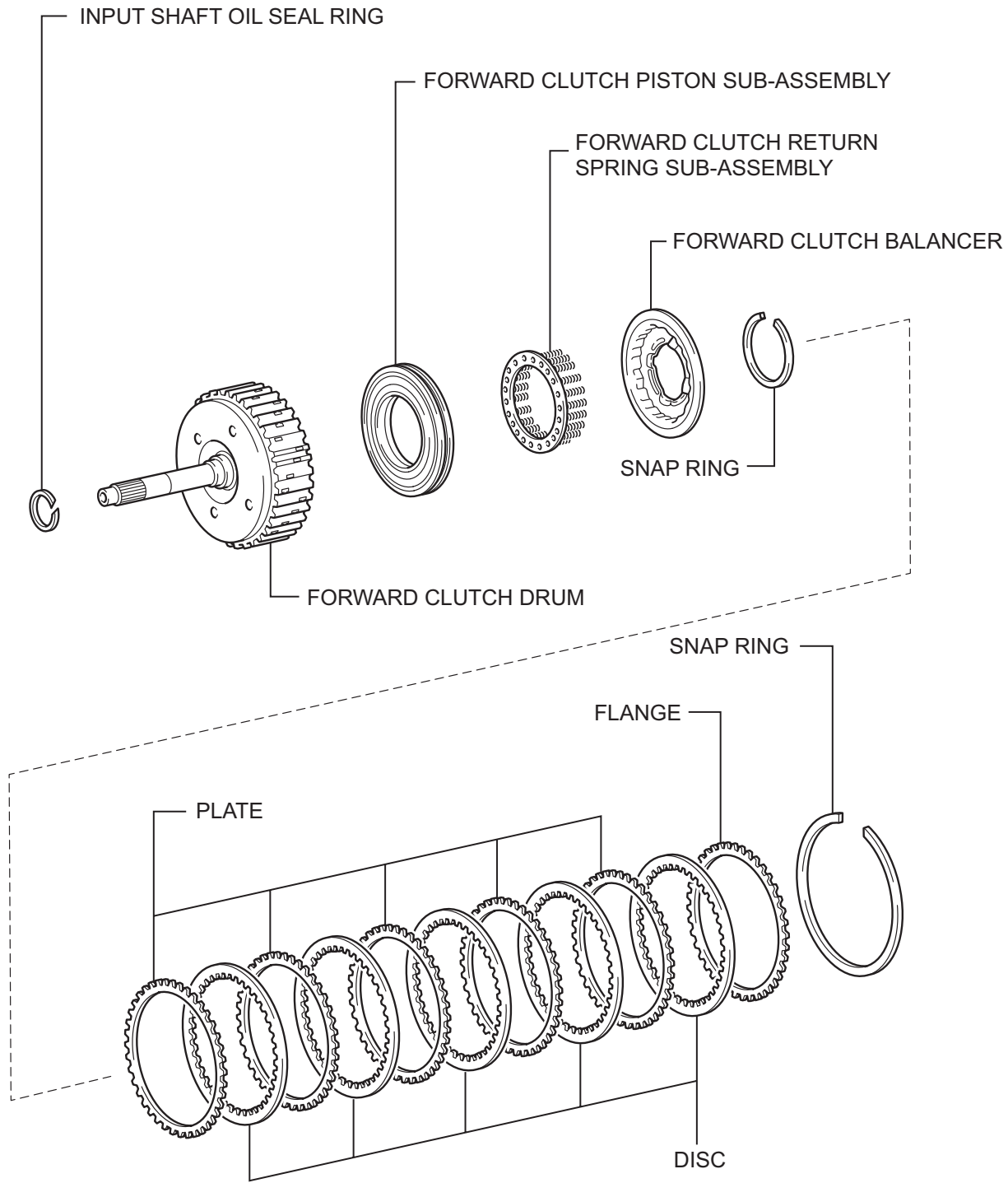

DISASSEMBLY

1. **INSPECT PACK CLEARANCE OF FORWARD CLUTCH** (See page [AX-256](#))
2. **REMOVE FORWARD MULTIPLE DISC CLUTCH DISC**
 - (a) Using a screwdriver, remove the snap ring.

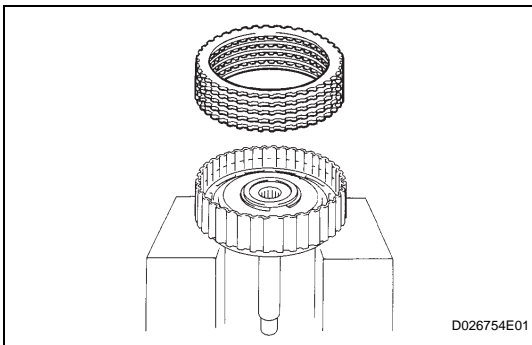
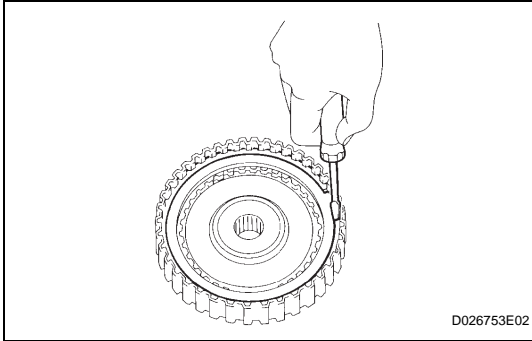

- (b) Remove the flange, 5 discs and 5 plates from the forward clutch drum.

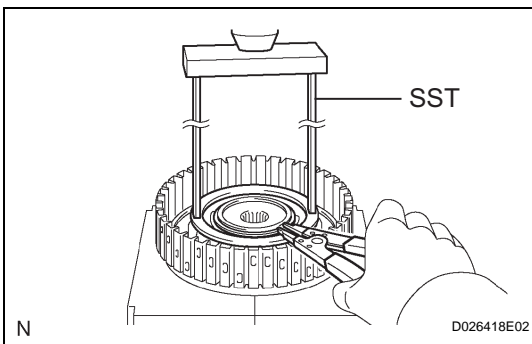

3. **REMOVE FORWARD CLUTCH RETURN SPRING SUB-ASSEMBLY**

- (a) Place SST on the spring retainer and compress the return spring with a press.

SST 09387-00020

- (b) Using a snap ring expander, remove the snap ring.

NOTICE:

- **Stop the press when the spring seat is lowered to a position 1 to 2 mm (0.039 to 0.078 in.) from the snap ring groove to prevent the spring seat from being deformed.**
- **Do not expand the snap ring excessively.**

- (c) Remove the clutch balancer from the forward clutch drum.

