

DTC**P0793****Intermediate Shaft Speed Sensor "A"****DESCRIPTION**

This sensor detects the rotation speed of the counter gear. By comparing the counter gear speed signal (NC) with the direct clutch speed sensor signal (NT), the ECM detects the shift timing of the gears and approximately controls the engine torque and hydraulic pressure according to various conditions. Thus smooth gear shifting is performed.

AX

DTC No.	DTC Detection Condition	Trouble Area
P0793	ECM detects conditions (a), (b) and (c) continuously for 5 sec. or more (1 trip detection logic): (a) Vehicle speed: 50 km/h (31 mph) or more (b) Park/Neutral position switch (NSW) is OFF (c) Speed sensor NC: Less than 300 rpm	<ul style="list-style-type: none"> • Open or short in speed sensor NC circuit • Speed sensor NC • ECM

MONITOR DESCRIPTION

The NC terminal of the ECM detects revolution signals from speed sensor NC (counter gear rpm). The ECM calculates gear shifts by comparing speed sensor NT with speed sensor NC.

While the vehicle is operating in the 2nd, 3rd, 4th or 5th gear position with the shift lever on D, if the counter gear revolution is less than 300 rpm*1 and the output shaft revolution is more than 1,000 rpm*2, the ECM detects the trouble, illuminates the MIL and stores the DTC.

*1: Pulse is not output or is irregularly output.

*2: The vehicle speed is 50 km/h (31 mph) or more.

MONITOR STRATEGY

Related DTCs	P0793: Speed sensor (NC)/Verify pulse input
Required sensors/Components	Speed sensor (NC), Speed sensor (NT), NSW switch
Frequency of operation	Continuous
Duration	5 sec.
MIL operation	Immediate
Sequence of operation	None

TYPICAL ENABLING CONDITIONS

The monitor will run whenever these DTCs are not present.	P0500 (VSS) P0748 - P0798 (Trans solenoid (Range))
Engine	Running
NSW switch	OFF
Output shaft rpm	1,000 rpm or more

TYPICAL MALFUNCTION THRESHOLDS

Sensor signal rpm	Less than 300 rpm
-------------------	-------------------

COMPONENT OPERATING RANGE

Counter gear speed sensor (NC)	3rd gear when shift lever is on D (after warming up the engine); Intermediate shaft speed (NC) becomes close to the engine speed
--------------------------------	---

WIRING DIAGRAM

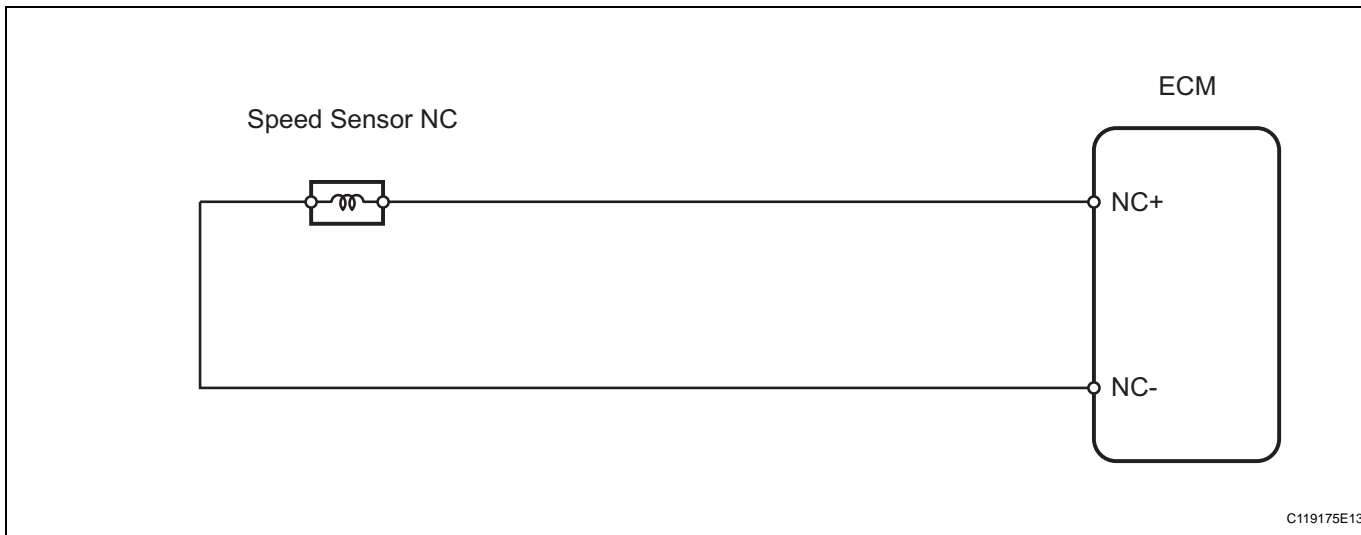

AX

INSPECTION PROCEDURE

HINT:

Using the intelligent tester's DATA LIST allows switch, sensor, actuator and other item values to be read without removing any parts. Reading the DATA LIST early in troubleshooting is one way to save time.

NOTICE:

In the table below, the values listed under "Normal Condition" are reference values. Do not depend solely on these reference values when deciding whether a part is faulty or not.

1. Warm up the engine.
2. Turn the ignition switch OFF.
3. Connect the intelligent tester to the CAN VIM. Then connect the CAN VIM to the DLC3.
4. Turn the ignition switch ON and turn the tester ON.
5. Enter the following menus: DIAGNOSIS / ENHANCED OBD II / DATA LIST.
6. Follow the instructions on the tester and read the DATA LIST.

ECM:

Item	Measurement Item/ Range (Display)	Normal Condition	Diagnostic Note
SPD (NC)	Counter gear speed/ Min.: 0 rpm Max.: 12,750 rpm	3rd gear when shift lever is on D (after warming up the engine); Intermediate shaft speed (NC) becomes close to the engine speed	Data is displayed in increments of 50 rpm

HINT:

- SPD (NC) is always 0 rpm while driving:
Open or short in the sensor or circuit.
- SPD (NC) is always more than 0 and less than 300 rpm while driving the vehicle at 50 km/h (31 mph) or more:
Sensor trouble, improper installation, or intermittent connection trouble of the circuit.

AX

1 INSPECT SPEED SENSOR (INSTALLATION)

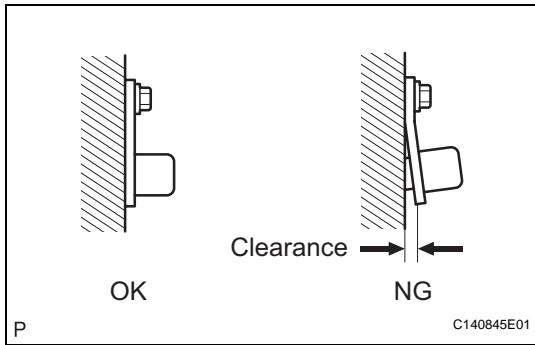

(a) Check the speed sensor NC installation.

OK:

Installation bolt is tightened properly and there is no clearance between the sensor and transaxle case.

NG → **REPLACE SPEED SENSOR NC**

OK

2 INSPECT SPEED SENSOR NC

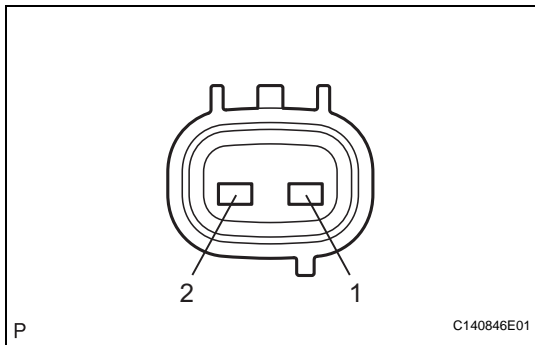

(a) Disconnect the B24 sensor connector from the transaxle.

(b) Measure the resistance of the sensor.

Standard resistance

Tester Connection	Condition	Specified Condition
1 - 2	20°C (68°F)	560 to 680 Ω

NG → **REPLACE SPEED SENSOR NC**

OK

3 CHECK WIRE HARNESS (SPEED SENSOR - ECM)

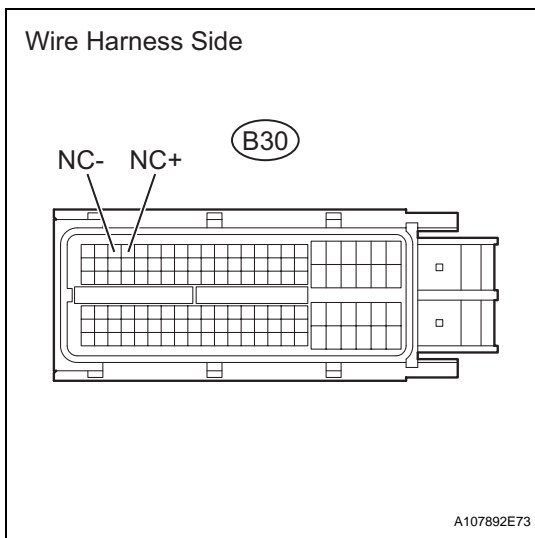

(a) Disconnect the B30 ECM connector.

(b) Measure the resistance of the wire harness side connector.

Standard resistance

Tester Connection	Specified Condition
B30-4 (NC+) - B30-3 (NC-)	560 to 680 Ω
B30-4 (NC+) - Body ground	10 kΩ or higher
B30-3 (NC-) - Body ground	10 kΩ or higher

NG → **REPAIR OR REPLACE HARNESS AND CONNECTOR**

OK

REPLACE ECM

AX