

DTC**P0717****Input Speed Sensor Circuit No Signal****DESCRIPTION**

This sensor detects the rotation speed of the turbine, which shows the input revolution of the transaxle. By comparing the input speed signal (NT) with the counter gear speed sensor signal (NC), the ECM detects the shift timing of the gears and controls the engine torque and hydraulic pressure according to various conditions. As a result, smooth gear shifting is achieved.

DTC No.	DTC Detection Condition	Trouble Area
P0717	ECM detects conditions (a), (b) and (c) continuously for 5 sec. or more (1 trip detection logic): (a) Vehicle speed: 50 km/h (31 mph) or more (b) Park/Neutral position switch (NSW, R and L) is OFF (c) Speed sensor NT: Less than 300 rpm	<ul style="list-style-type: none"> • Open or short in speed sensor NT circuit • Speed sensor NT • ECM

MONITOR DESCRIPTION

This DTC indicates that a pulse is not output from the speed sensor NT (input speed sensor) or is output only a little. The NT terminal of the ECM detects the revolving signal from the speed sensor (NT) (input RPM). The ECM outputs a gear shift signal comparing the input speed sensor (NT) with the output speed sensor (NC).

While the vehicle is operating in the 2nd, 3rd, 4th or 5th gear position with the shift lever on D, if the input shaft revolution is less than 300 rpm*1 and the output shaft revolution is 1,000 rpm or more*2, the ECM detects the trouble, illuminates the MIL and stores the DTC.

HINT:

*1: Pulse is not output or is irregularly output.

*2: The vehicle speed is approximately 50 km/h (31 mph) or more.

MONITOR STRATEGY

Related DTCs	P0717: Speed sensor (NT)/Verify pulse input
Required sensors/Components	Speed sensor (NT), Speed sensor (NC)
Frequency of operation	Continuous
Duration	5 sec.
MIL operation	Immediate
Sequence of operation	None

TYPICAL ENABLING CONDITIONS

The monitor will run whenever these DTCs are not present.	P0500 (VSS) P0748 - P0798 (Trans solenoid (Range))
Shift change	Shift change is completed before starting next shift change operation
ECM selected gear	2nd, 3rd, 4th or 5th
Output shaft rpm	1,000 rpm or more
NSW switch	OFF
R switch	OFF
L switch	OFF
Engine	Running
Ignition switch	ON
Starter	OFF

AX

TYPICAL MALFUNCTION THRESHOLDS

Sensor signal rpm	Less than 300 rpm
-------------------	-------------------

COMPONENT OPERATING RANGE

AX

Speed sensor (NT)	Input speed is equal to engine speed when lock-up ON.
-------------------	---

WIRING DIAGRAM

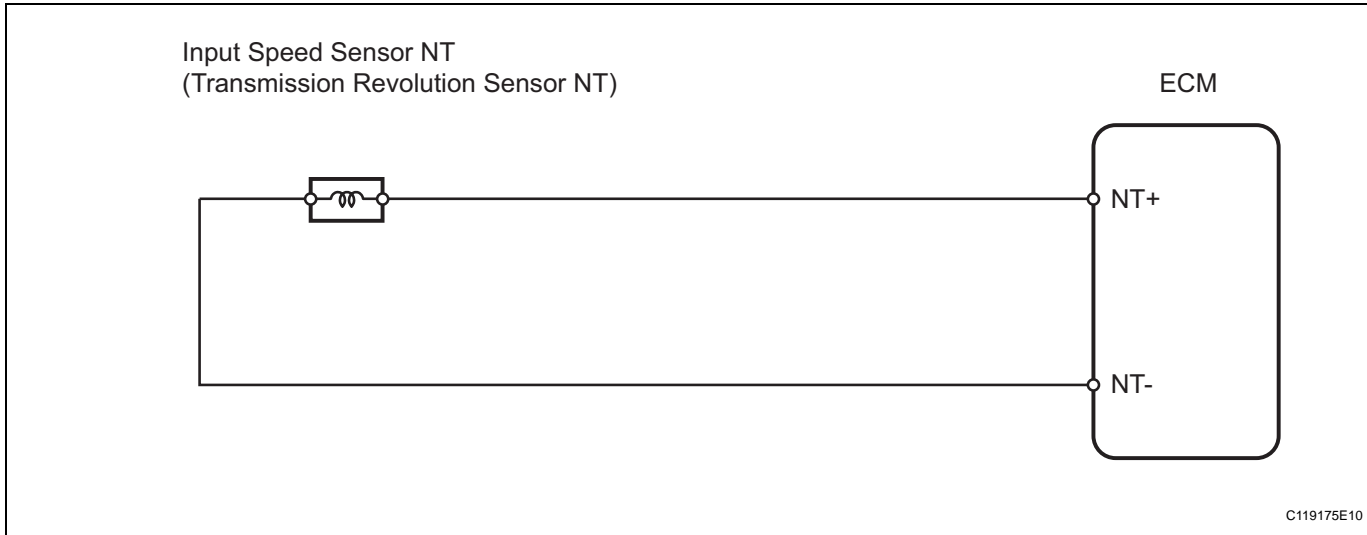

INSPECTION PROCEDURE

HINT:

Using the intelligent tester's DATA LIST allows switch, sensor, actuator and other item values to be read without removing any parts. Reading the DATA LIST early in troubleshooting is one way to save time.

NOTICE:

In the table below, the values listed under "Normal Condition" are reference values. Do not depend solely on these reference values when deciding whether a part is faulty or not.

1. Warm up the engine.
2. Turn the ignition switch OFF.
3. Connect the intelligent tester to the CAN VIM. Then connect the CAN VIM to the DLC3.
4. Turn the ignition switch ON and turn the tester ON.
5. Enter the following menus: DIAGNOSIS / ENHANCED OBD II / DATA LIST.
6. Follow the instructions on the tester and read the DATA LIST.

ECM:

Item	Measurement Item/Range (Display)	Normal Condition	Diagnostic Note
SPD (NT)	Input turbine speed/ Min.: 0 rpm Max.: 12,750 rpm	<ul style="list-style-type: none"> • Lock-up ON (after warming up engine): Input turbine speed (NT) is equal to engine speed. • Lock-up OFF (idling with shift lever on N): Input turbine speed (NT) is nearly equal to engine speed. 	Data is displayed in increments of 50 rpm

HINT:

- SPD (NT) is always 0 rpm while driving:
Open or short in the sensor or circuit.

- SPD (NT) is always more than 0 rpm and less than 300 rpm while driving the vehicle at 50 km/h (31 mph) or more:
Sensor trouble, improper installation, or intermittent connection trouble of the circuit.

AX

1 INSPECT SPEED SENSOR (INSTALLATION)

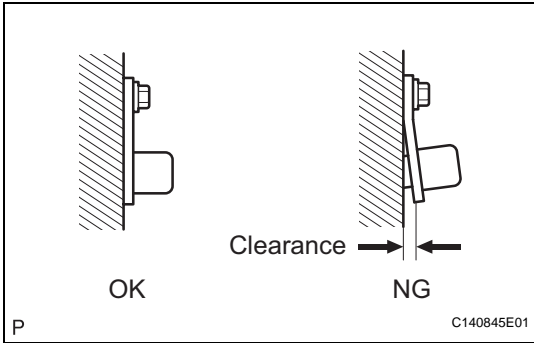

(a) Check the speed sensor NT installation.

OK:

Installation bolt is tightened properly and there is no clearance between the sensor and transaxle case.

NG → **SECURELY INSTALL SENSOR OR REPLACE SPEED SENSOR**

OK

2 INSPECT SPEED SENSOR NT

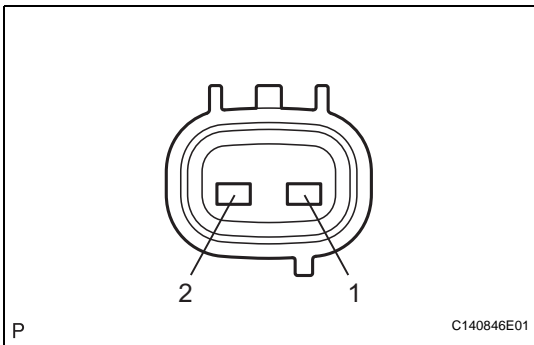

- (a) Disconnect the B28 sensor connector from the transaxle.
- (b) Measure the resistance of the sensor.

Standard resistance

Tester Connection	Condition	Specified Condition
1 - 2	20°C (68°F)	560 to 680 Ω

NG → **REPLACE SPEED SENSOR NT**

OK

3 CHECK WIRE HARNESS (SPEED SENSOR - ECM)

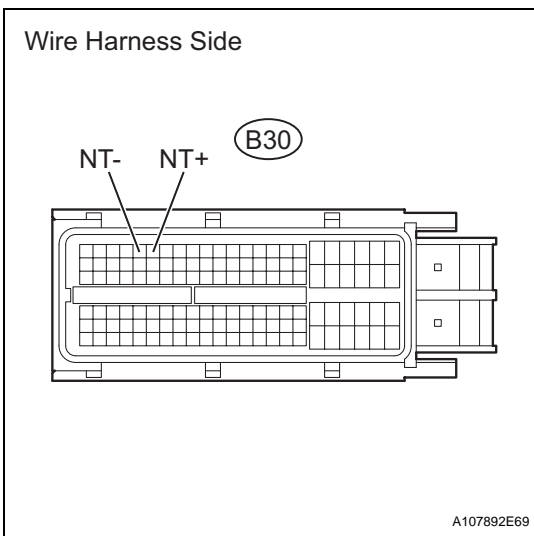

- (a) Disconnect the B30 ECM connector.
- (b) Measure the resistance of the wire harness side connector.

Standard resistance

Tester Connection	Condition	Specified Condition
B30-6 (NT+) - B30-5 (NT-)	20°C (68°F)	560 to 680 Ω
B30-6 (NT+) - Body ground	20°C (68°F)	10 kΩ or higher
B30-5 (NT-) - Body ground	20°C (68°F)	10 kΩ or higher

NG → **REPAIR OR REPLACE HARNESS AND CONNECTOR**

OK

REPLACE ECM

AX