

OIL PUMP COMPONENTS

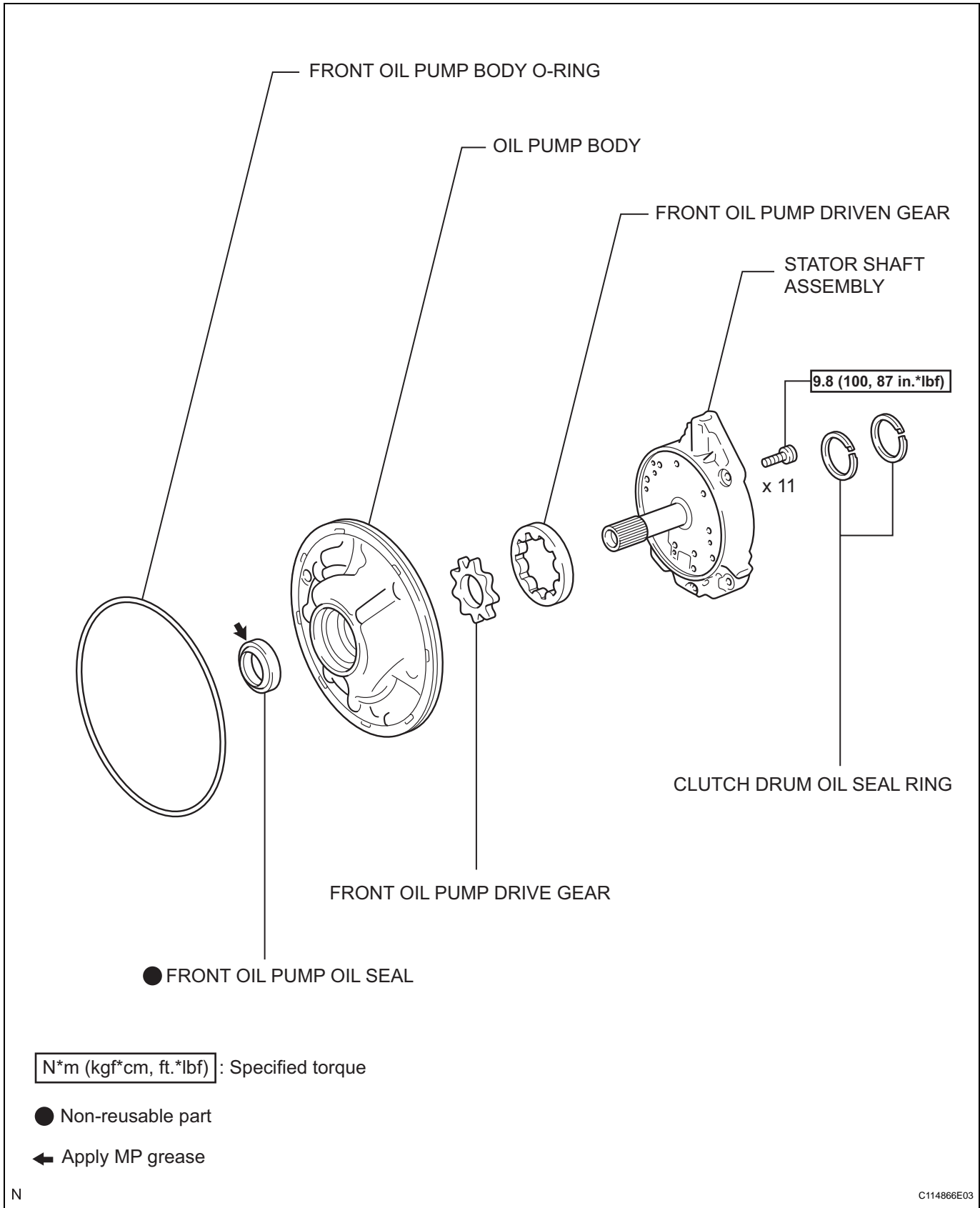

DISASSEMBLY

1. **INSPECT OIL PUMP ASSEMBLY** (See page [AX-246](#))
2. **REMOVE CLUTCH DRUM OIL SEAL RING**
 - (a) Remove the 2 clutch drum oil seal rings.

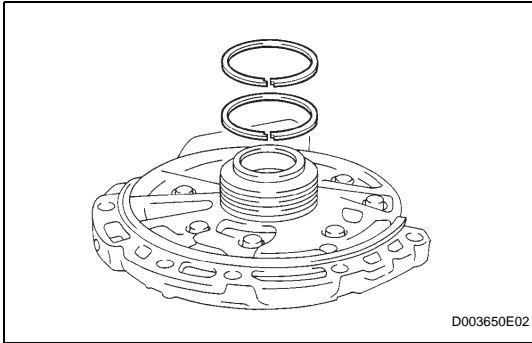

3. **REMOVE STATOR SHAFT ASSEMBLY**
 - (a) Using a T30 "torx" socket, remove the 11 bolts and stator shaft.

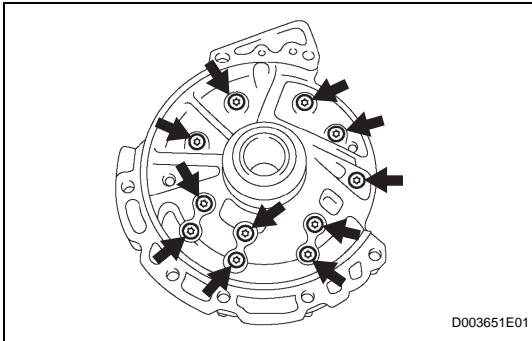

4. **INSPECT CLEARANCE OF OIL PUMP ASSEMBLY** (See page [AX-246](#))

5. **REMOVE FRONT OIL PUMP DRIVE GEAR**

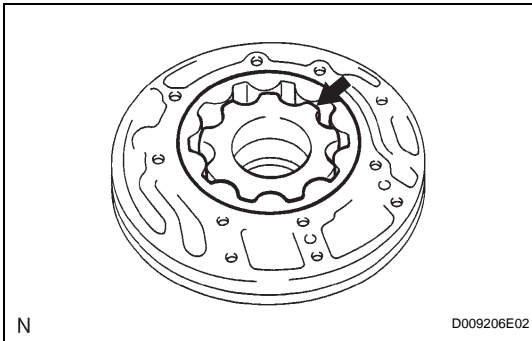

6. **REMOVE FRONT OIL PUMP DRIVEN GEAR**

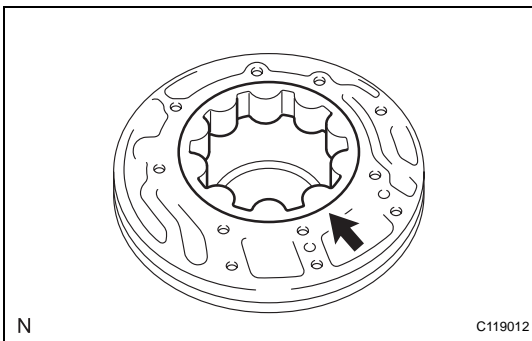

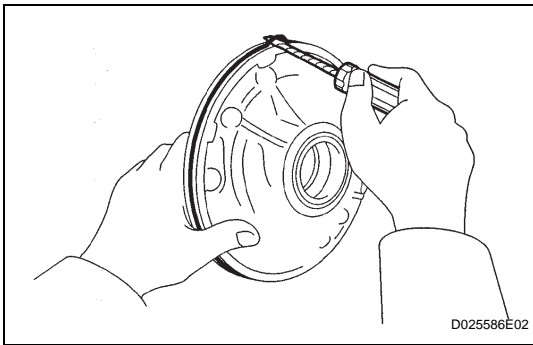

7. REMOVE FRONT OIL PUMP BODY O-RING

- (a) Using a screwdriver, pry out the O-ring.

HINT:

Tape the screwdriver tip before use.

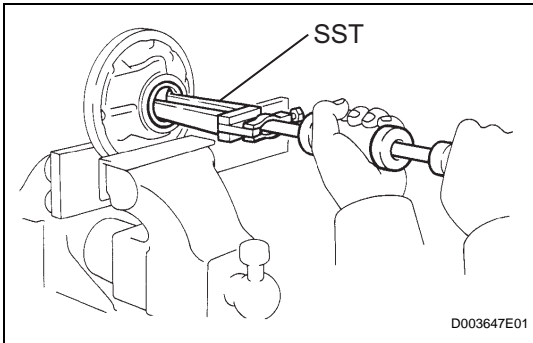

8. REMOVE FRONT OIL PUMP OIL SEAL

- (a) Mount the oil pump in a soft jaw vise.

- (b) Using SST, remove the oil seal from the oil pump body.

SST 09308-00010

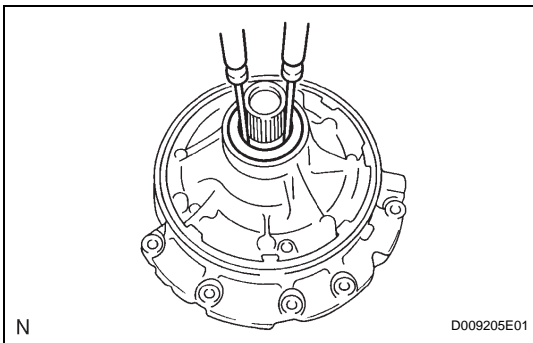

INSPECTION

1. INSPECT OIL PUMP ASSEMBLY

- (a) Turn the drive gear with 2 screwdrivers and make sure that it rotates smoothly.

NOTICE:

Be careful not to damage the lip of the oil seal.

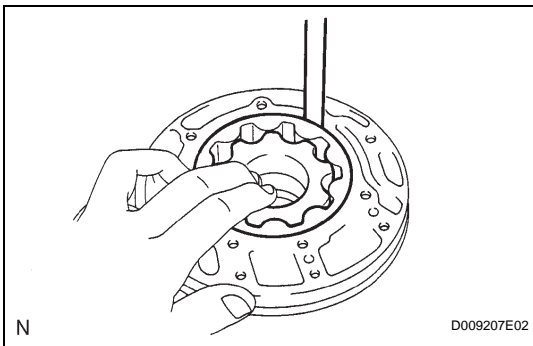

2. INSPECT CLEARANCE OF OIL PUMP ASSEMBLY

- (a) Push the driven gear to one side of the body.
- (b) Using a feeler gauge, measure the body clearance between the driven gear and oil pump body.

Standard body clearance:

0.10 to 0.17 mm (0.0039 to 0.0067 in.)

Maximum body clearance:

0.17 mm (0.0067 in.)

If the body clearance is greater than the maximum, replace the oil pump body sub-assembly.

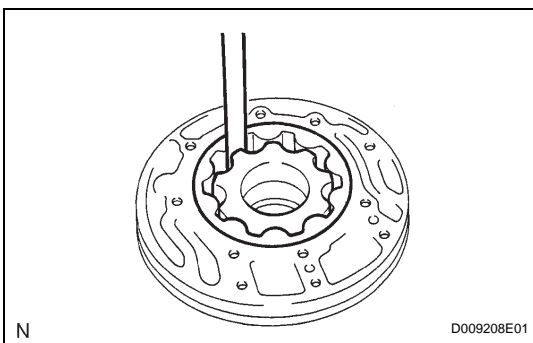

- (c) Using a feeler gauge, measure the tip clearance between the driven gear teeth and drive gear teeth.

Standard tip clearance:

0.07 to 0.15 mm (0.0028 to 0.0059 in.)

Maximum tip clearance:

0.15 mm (0.0059 in.)

If the tip clearance is greater than the maximum, replace the oil pump body.

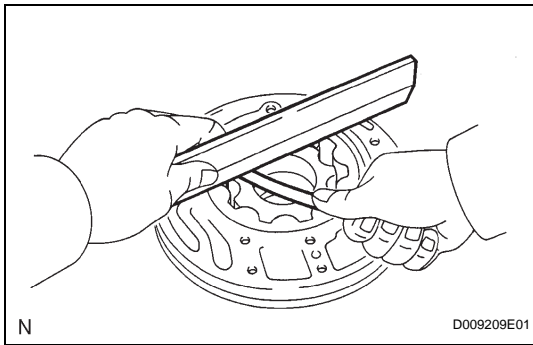

- (d) Using a straightedge and feeler gauge, measure the side clearance of both gears.

Standard side clearance:

0.02 to 0.05 mm (0.0008 to 0.0020 in.)

Maximum side clearance:

0.05 mm (0.0020 in.)

Standard drive gear thickness

Mark	Thickness
A	11.690 to 11.699 mm (0.4602 to 0.4606 in.)
B	11.700 to 11.709 mm (0.4606 to 0.4610 in.)
C	11.710 to 11.720 mm (0.4610 to 0.4614 in.)
D	11.721 to 11.730 mm (0.4615 to 0.4618 in.)
E	11.731 to 11.740 mm (0.4619 to 0.4622 in.)

Standard driven gear thickness

Mark	Thickness
A	11.690 to 11.699 mm (0.4602 to 0.4606 in.)
B	11.700 to 11.709 mm (0.4606 to 0.4610 in.)
C	11.710 to 11.720 mm (0.4610 to 0.4614 in.)
D	11.721 to 11.730 mm (0.4615 to 0.4618 in.)
E	11.731 to 11.740 mm (0.4619 to 0.4622 in.)

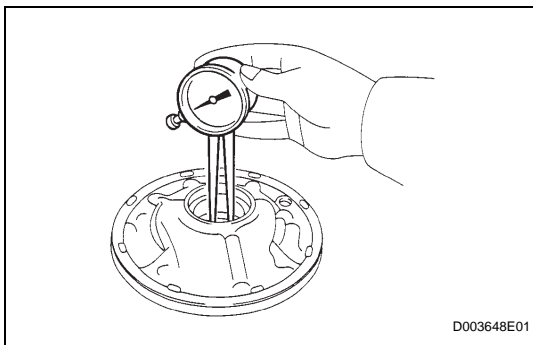

3. INSPECT FRONT OIL PUMP AND GEAR BODY SUB-ASSEMBLY

- (a) Using a caliper gauge, measure the inside diameter of the oil pump body bushing.

Standard inside diameter:

38.113 to 38.138 mm (1.5005 to 1.5015 in.)

Maximum inside diameter:

38.188 mm (1.5035 in.)

If the inside diameter is greater than the maximum, replace the oil pump body sub-assembly.

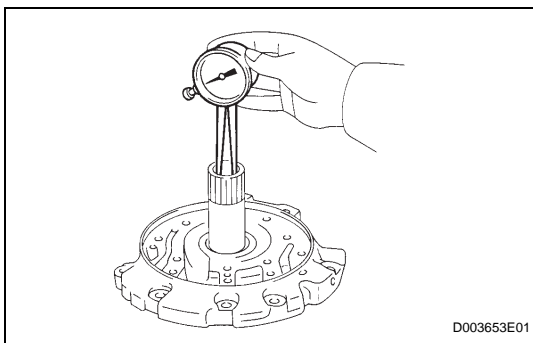

4. INSPECT STATOR SHAFT ASSEMBLY

- (a) Using a caliper gauge, measure the inside diameter of the stator shaft.

Standard inside diameter:

21.500 to 21.526 mm (0.8465 to 0.8475 in.)

Maximum inside diameter:

21.57 mm (0.8492 in.)

If the inside diameter is greater than the maximum, replace the stator shaft.