

DTC	P0741	Torque Converter Clutch Solenoid Performance (Shift Solenoid Valve DSL)
------------	--------------	--

DESCRIPTION

The ECM uses the signals from the throttle position sensor, air-flow meter, turbine (input) speed sensor, intermediate (counter) shaft speed sensor and crankshaft position sensor to monitor the engagement condition of the lock-up clutch.

Then the ECM compares the engagement condition of the lock-up clutch with the lock-up schedule in the ECM memory to detect mechanical problems of the shift solenoid valve DSL, valve body and torque converter clutch.

DTC No.	DTC Detection Condition	Trouble Area
P0741	Lock-up does not occur when driving in the lock-up range (normal driving at 80 km/h [50 mph]), or lock up remains ON in the lock-up OFF range (2 trip detection logic)	<ul style="list-style-type: none"> • Shift solenoid valve DSL remains open or closed • Valve body is blocked • Shift solenoid valve DSL • Torque converter clutch • Automatic transaxle (clutch, brake, gear, etc.) • Line pressure is too low • ECM

MONITOR DESCRIPTION

Torque converter lock-up is controlled by the ECM based on the speed sensor (NT), speed sensor (NC), engine rpm, engine load, engine temperature, vehicle speed, transmission temperature, and gear selection. The ECM determines the lock-up status of the torque converter by comparing the engine rpm (NE) to the input turbine rpm (NT). The ECM calculates the actual transmission gear by comparing input turbine rpm (NT) to counter gear rpm (NC). When conditions are appropriate, the ECM requests "lock-up" by applying control voltage to the shift solenoid DSL. When the DSL is turned on, it applies pressure to the lock-up relay valve and locks the torque converter clutch.

If the ECM detects no lock-up after lock-up has been requested or if it detects lock-up when it is not requested, the ECM interprets this as a fault in the shift solenoid valve DSL or lock-up system performance. The ECM will turn on the MIL and store the DTC.

HINT:

Example:

When either of the following is met, the system judges it as a malfunction.

- There is a difference in rotation between the input side (engine speed) and output side (input turbine speed) of the torque converter when the ECM commands lock-up.
(Engine speed is at least 75 rpm greater than input turbine speed.)
- There is no difference in rotation between the input side (engine speed) and output side (input turbine speed) of the torque converter when the ECM commands lock-up off.
(The difference between engine speed and input turbine speed is less than 35 rpm.)

MONITOR STRATEGY

Related DTCs	P0741: Shift solenoid valve DSL/OFF malfunction Shift solenoid valve DSL/ON malfunction
Required sensors/Components	Shift solenoid valve DSL, Speed sensor (NT), Speed sensor (NC), Crankshaft position sensor (NE), Throttle position sensor (VPA1), Mass air flow sensor (MAF), Transmission temperature sensor (THO1), Engine coolant temperature sensor (ECT)
Frequency of operation	Continuous
Duration	OFF malfunction 3.5 sec. ON malfunction 1.8 sec.

MIL operation	2 driving cycles
Sequence of operation	None

TYPICAL ENABLING CONDITIONS

ALL:

The monitor will run whenever these DTCs are not present.	P0115 - P0118 (ECT sensor) P0125 (Insufficient ECT for closed loop) P0500 (VSS) P0748, P0778, P0798 (Shift solenoid valve (range))
ECT (Engine coolant temperature)	10°C (50°F) or more
Transmission range	"D"
ATF temperature	-20°C (-4°F) or more
ATF temperature sensor circuit	Not circuit malfunction
ECT sensor circuit	Not circuit malfunction
Turbine speed sensor circuit	Not circuit malfunction
Intermediate shaft speed sensor circuit	Not circuit malfunction
Output speed sensor circuit	Not circuit malfunction
Shift solenoid valve SL1 circuit	Not circuit malfunction
Shift solenoid valve SL2 circuit	Not circuit malfunction
Shift solenoid valve SL3 circuit	Not circuit malfunction
Shift solenoid valve S4 circuit	Not circuit malfunction
Shift solenoid valve SR circuit	Not circuit malfunction
Shift solenoid valve DSL circuit	Not circuit malfunction
Electronic throttle system	Not circuit malfunction

OFF malfunction

ECM lock-up command	ON
ECM selected gear	3rd, 4th or 5th
Vehicle speed	25 km/h (15.5 mph) or more

ON malfunction

ECM lock-up command	OFF
ECM selected gear	3rd, 4th or 5th
Throttle valve opening angle	7% or more
Vehicle speed	25 to 60 km/h (15.5 to 37.3 mph)

TYPICAL MALFUNCTION THRESHOLDS

Either of the following conditions is met: OFF malfunction or ON malfunction

OFF malfunction:

Engine Speed - Input (turbine) speed	100 rpm or more
--------------------------------------	-----------------

ON malfunction:

Difference between engine speed and input (turbine) speed	Less than 35 rpm
---	------------------

WIRING DIAGRAM

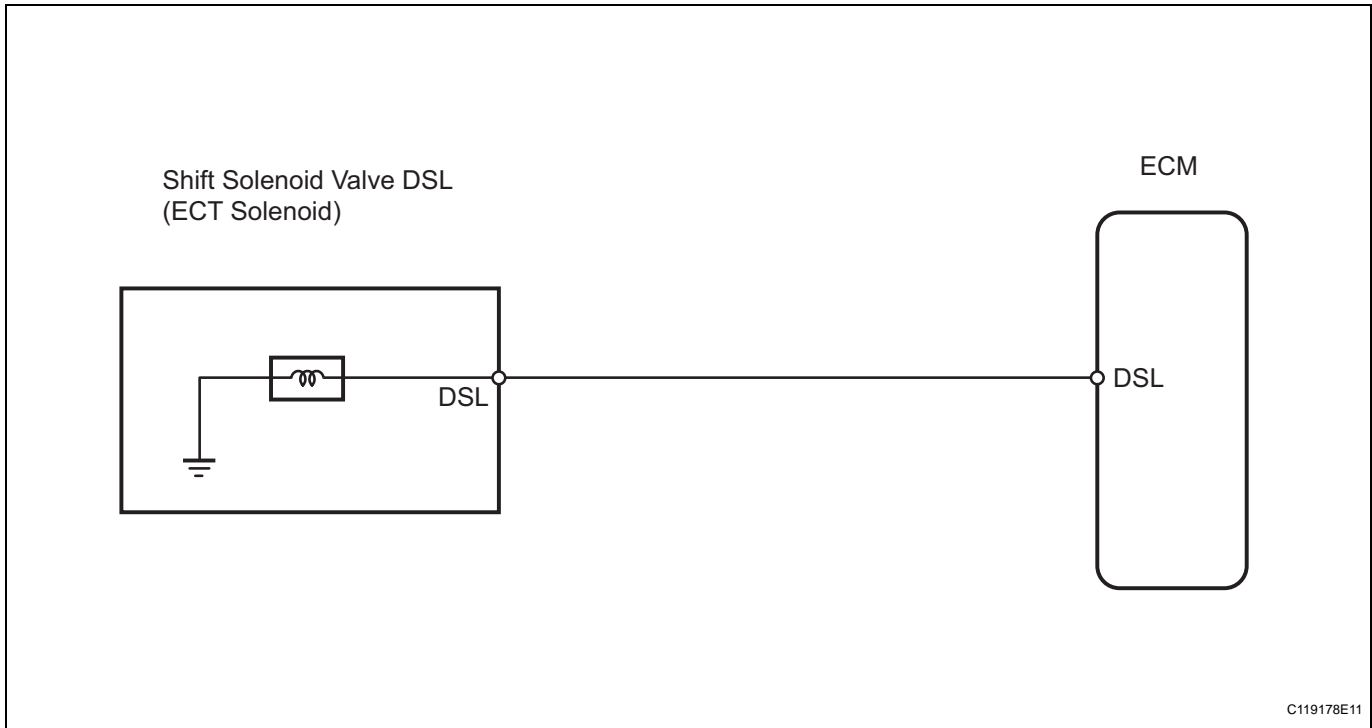

INSPECTION PROCEDURE

HINT:

Performing the intelligent tester's ACTIVE TEST allows relay, VSV, actuator and other items to be operated without removing any parts. Performing the ACTIVE TEST early in troubleshooting is one way to save time.

The DATA LIST can be displayed during the ACTIVE TEST.

1. Warm up the engine.
2. Turn the ignition switch OFF.
3. Connect the intelligent tester to the CAN VIM. Then connect the CAN VIM to the DLC3.
4. Turn the ignition switch ON and turn the tester ON.
5. Enter the following menus: DIAGNOSIS / ENHANCED OBD II / ACTIVE TEST.
6. Follow the instructions on the tester and perform the ACTIVE TEST.

ECM:

Item	Test Details	Diagnostic Note
LOCK UP	[Test Details] Control shift solenoid DSL to set automatic transaxle to the lock-up condition [Vehicle Condition] <ul style="list-style-type: none"> • Throttle valve opening angle: Less than 35% • Vehicle speed: 60 km/h (36 mph) or more 	Possible to check shift solenoid valve DSL operation

HINT:

- This test can be conducted when the vehicle speed is 60 km/h (36 mph) or more.
 - This test can be conducted in the 5th gear.
7. Lightly depress the accelerator pedal and check that the engine speed does not change abruptly.

HINT:

- When changing the accelerator pedal opening angle while driving, if the engine speed does not change, lock-up is ON.
- Slowly release the accelerator pedal in order to decelerate. (Do not fully release the pedal as that will close the throttle valve and lock-up may be turned OFF.)

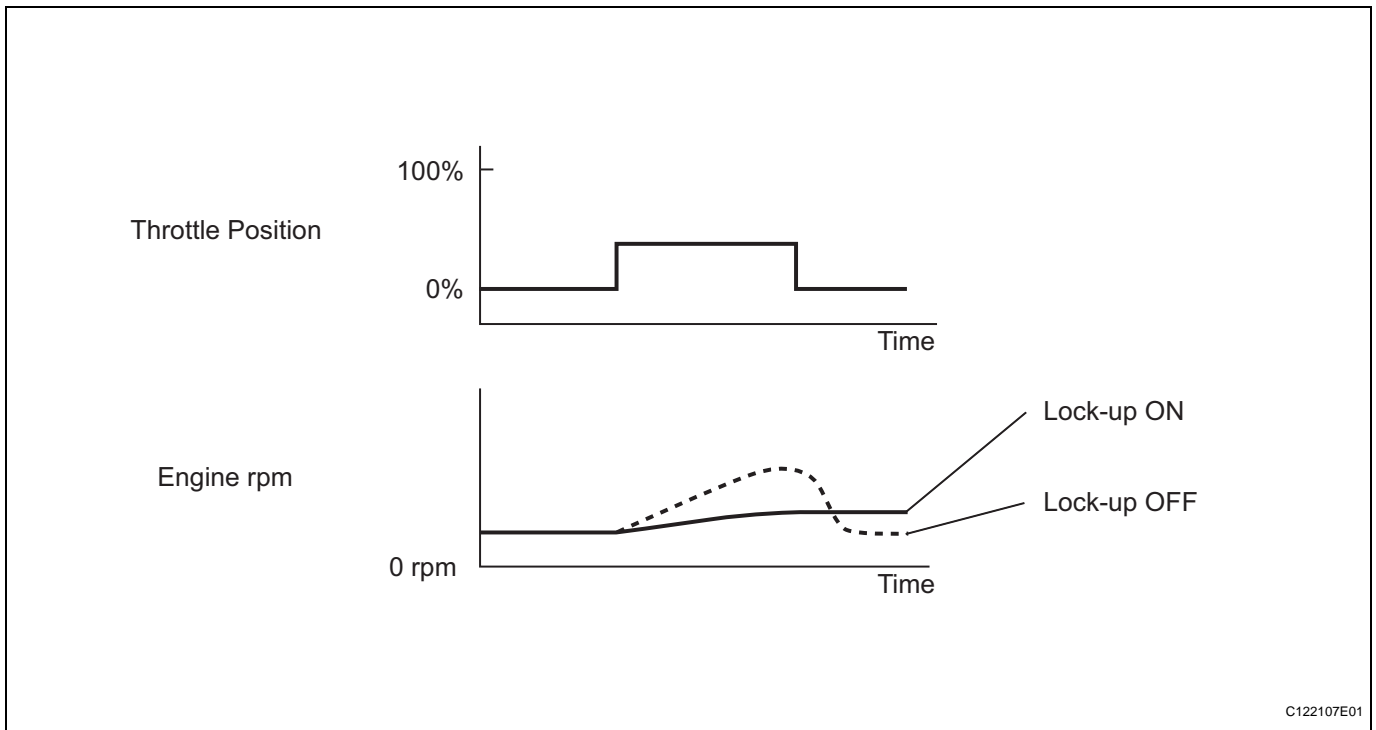

C122107E01

1 CHECK OTHER DTC OUTPUT (IN ADDITION TO DTC P0741)

- (a) Connect the intelligent tester to the CAN VIM. Then connect the CAN VIM to the DLC3.
- (b) Turn the ignition switch ON and turn the tester ON.
- (c) Enter the following menus: DIAGNOSIS / ENHANCED OBD II / DTC INFO / CURRENT CODES.
- (d) Read the DTCs using the tester.

Result

Display (DTC output)	Proceed to
Only P0741 is output	A
P0741 and other DTCs are output	B

HINT:

If any other codes besides P0741 are output, perform troubleshooting for those DTCs first.

B **GO TO DTC CHART**

A

2 INSPECT TRANSMISSION WIRE (SHIFT SOLENOID VALVE DSL)

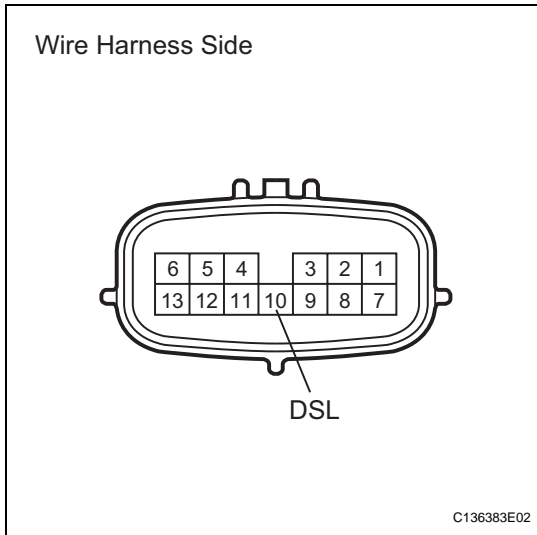

- (a) Disconnect the B32 wire connector.
- (b) Measure the resistance of the transmission wire.

Standard resistance

Tester Connection	Condition	Specified Condition
10 (DSL) - Body ground	20°C (68°F)	11 to 13 Ω

NG → **Go to step 4**

OK

3 CHECK WIRE HARNESS (TRANSMISSION WIRE - ECM)

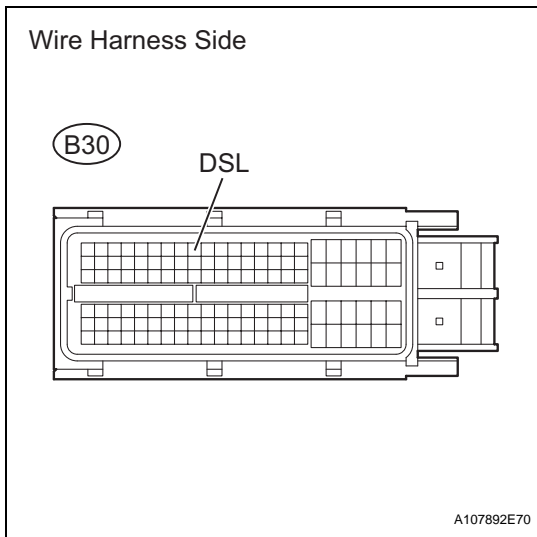

- (a) Disconnect the B30 ECM connector.
- (b) Measure the resistance of the wire harness side connector.

Standard resistance

Tester Connection	Condition	Specified Condition
B30-9 (DSL) - Body ground	20°C (68°F)	11 to 13 Ω

NG → **REPAIR OR REPLACE HARNESS AND CONNECTOR**

OK

REPLACE ECM

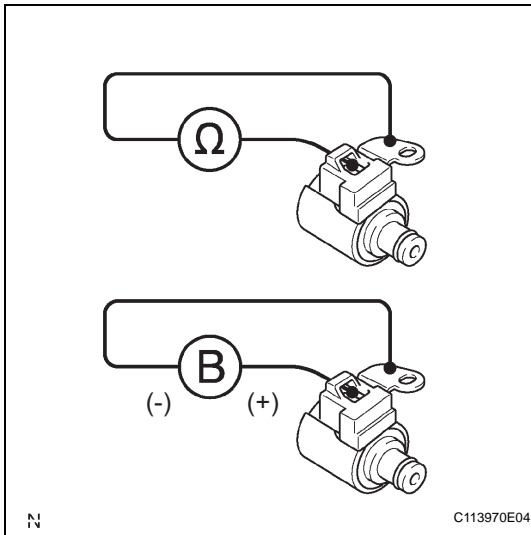
4 INSPECT SHIFT SOLENOID VALVE DSL

- (a) Remove the shift solenoid valve DSL.
 (b) Measure the resistance of the solenoid valve.
Standard resistance:
11 to 13 Ω at 20°C (68°F)
 (c) Connect the battery's positive (+) lead to the terminal of the solenoid valve connector, and the negative (-) lead to the solenoid body. Then check that the valve moves and makes an operating noise.

OK:

Valve moves and makes operating noise.

NG**REPLACE SHIFT SOLENOID VALVE DSL****OK****5 CHECK TRANSMISSION WIRE****OK:**

The connectors and pins are securely installed.
 There is no open or short on the wire harness.

NG**REPAIR OR REPLACE TRANSMISSION WIRE****OK****6 INSPECT TRANSMISSION VALVE BODY ASSEMBLY**

- (a) Check the transmission valve body assembly.

OK:

There are no foreign objects on each valve.

NG**REPAIR OR REPLACE TRANSMISSION VALVE BODY ASSEMBLY****OK****7 INSPECT TORQUE CONVERTER CLUTCH ASSEMBLY**

- (a) Check the torque converter clutch assembly (see page
- [AX-178](#)
-).

OK:

The torque converter clutch operates normally.

NG**REPLACE TORQUE CONVERTER CLUTCH ASSEMBLY****AX**

OK

REPAIR AUTOMATIC TRANSAXLE ASSEMBLY