

SYSTEM DIAGRAM

The configuration of the electronic control system in the U151E automatic transaxle is as shown in the following chart.

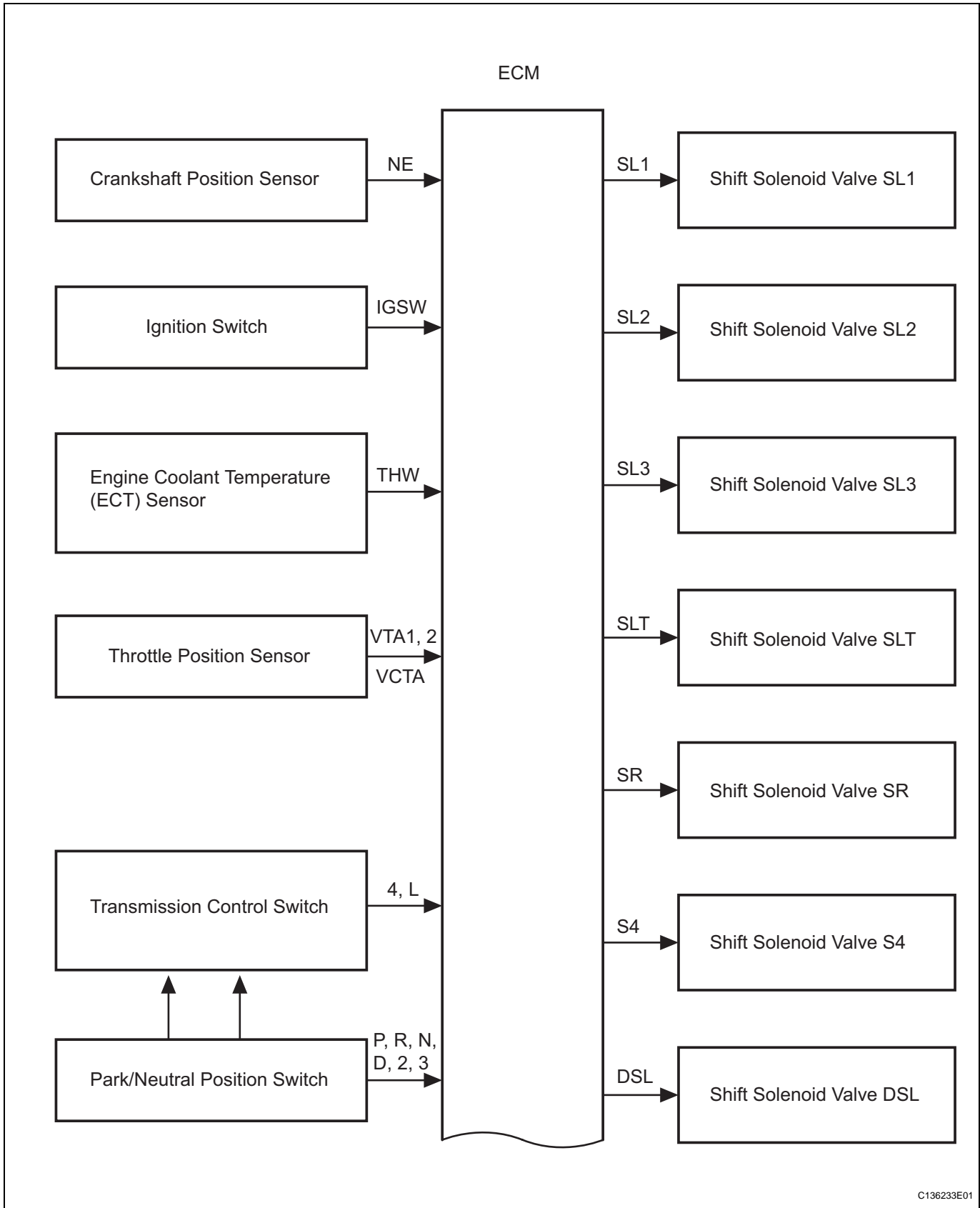

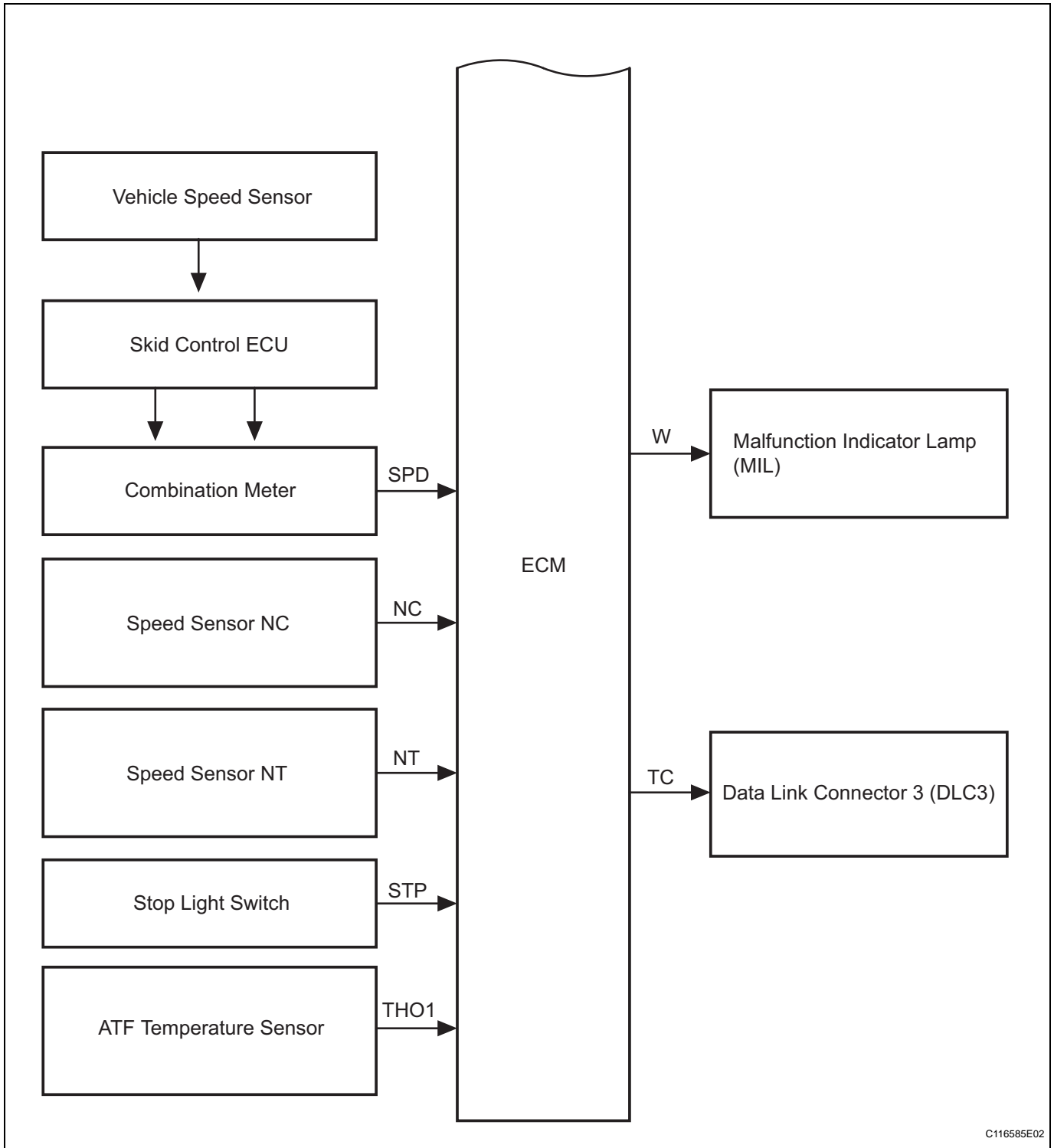

C116585E02

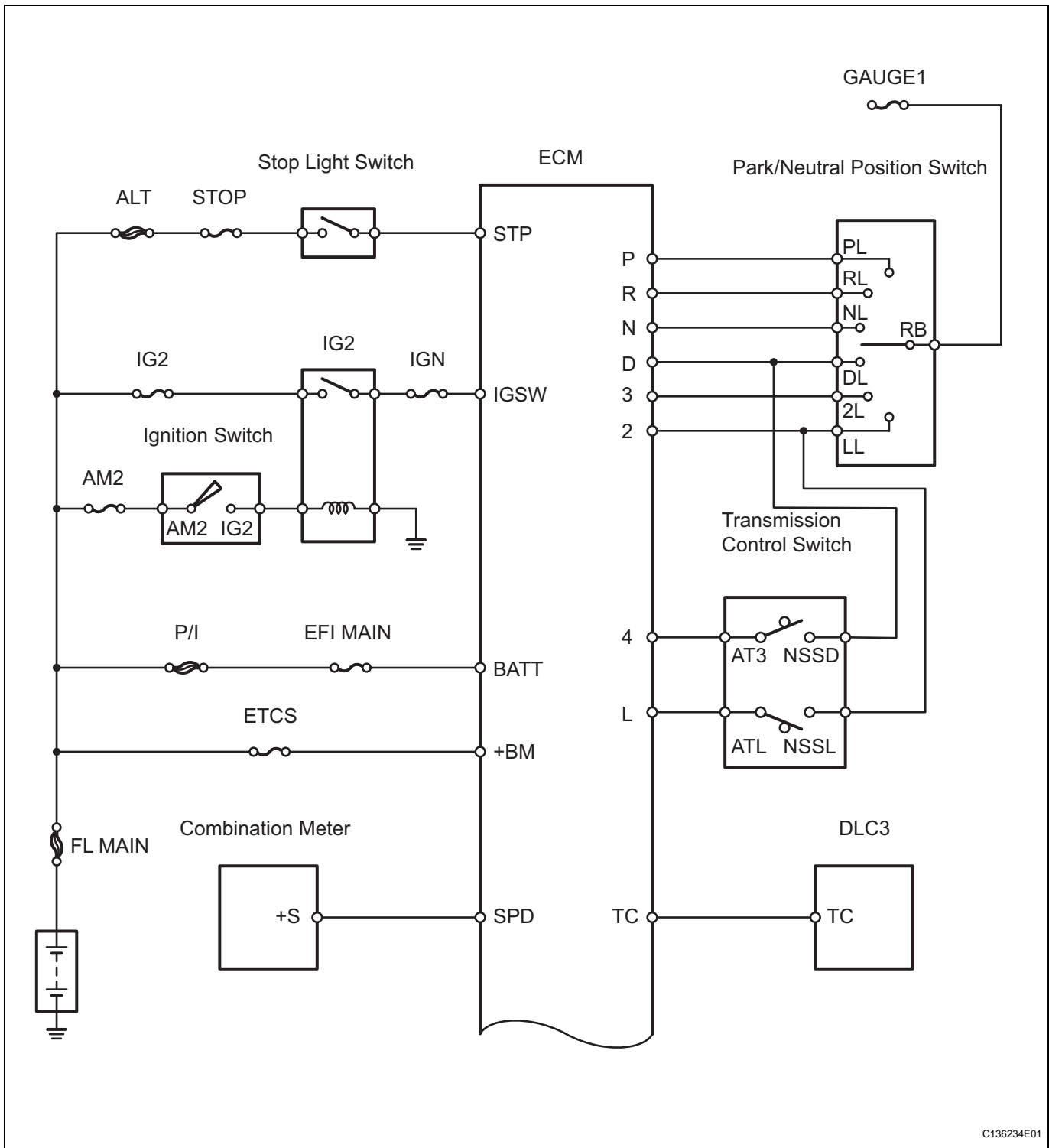

C136234E01

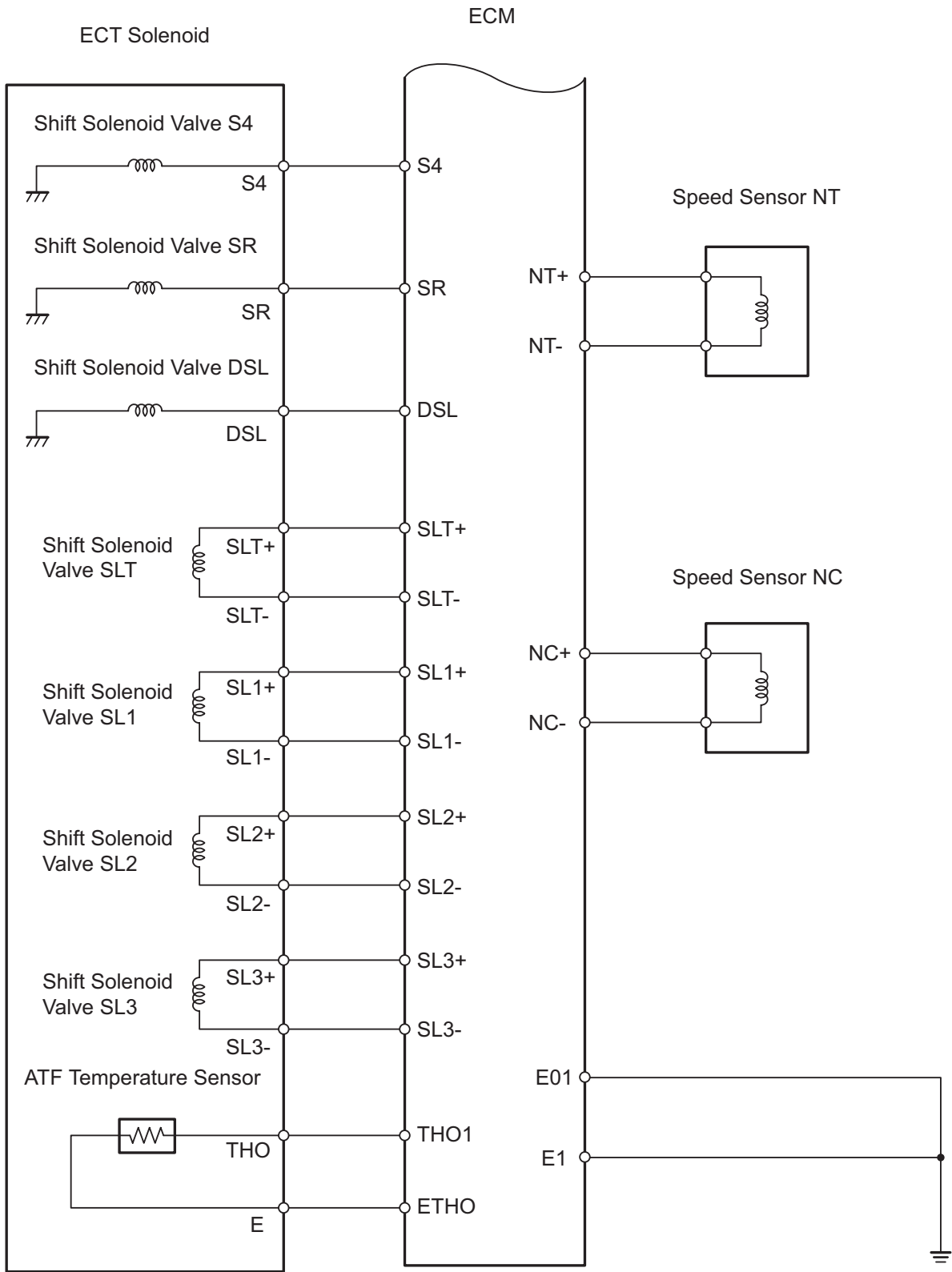

C136235E01