

DTC	P2716	Pressure Control Solenoid "D" Electrical (Shift Solenoid Valve SLT)
------------	--------------	--

DESCRIPTION

Refer to DTC P2714 (see page [AX-91](#)).

DTC No.	DTC Detection Condition	Trouble Area
P2716	Condition (a) and (b) below is detected for 1 sec. or more (1 trip detection logic): (a) SLT - terminal: 0 V (b) SLT - terminal: 12 V	<ul style="list-style-type: none"> • Open or short in shift solenoid valve SLT circuit • Shift solenoid valve SLT • ECM

MONITOR DESCRIPTION

When an open or short in the shift solenoid valve SLT circuit is detected, the ECM interprets this as a fault. The ECM will illuminate the MIL and store the DTC.

MONITOR STRATEGY

Related DTCs	P2716: Shift solenoid valve SLT/Range check
Required sensors/Components	Shift solenoid valve SLT
Frequency of operation	Continuous
Duration	1 sec.
MIL operation	Immediate
Sequence of operation	None

TYPICAL ENABLING CONDITIONS

The monitor will run whenever this DTC is not present.	None
Battery voltage	11 V or more
Solenoid current cut status	Not cut
CPU command duty ratio to SLT	19% or more
Starter	OFF
Ignition switch	ON

TYPICAL MALFUNCTION THRESHOLDS

Solenoid status from IC	Fail (open or short)
-------------------------	----------------------

COMPONENT OPERATING RANGE

Shift solenoid valve SLT	Resistance: 5.0 to 5.6 Ω at 20°C (68°F)
--------------------------	--

WIRING DIAGRAM

Refer to DTC P2714 (see page [AX-91](#)).

INSPECTION PROCEDURE

1 INSPECT TRANSMISSION WIRE (SHIFT SOLENOID VALVE SLT)

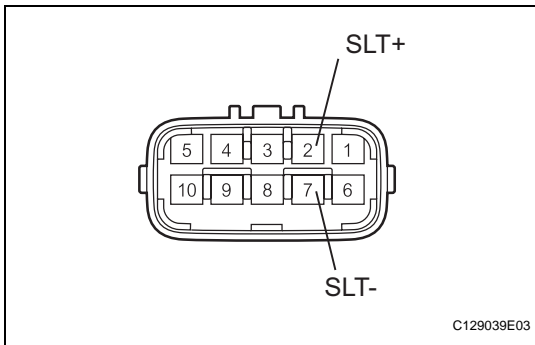

- (a) Disconnect the B27 wire connector.
- (b) Measure the resistance of the transmission wire.

Standard resistance

Tester Connection	Condition	Specified Condition
2 (SLT+) - 7 (SLT-)	20°C (68°F)	5.0 to 5.6 Ω
2 (SLT+) - Body ground	20°C (68°F)	1 MΩ or higher
7 (SLT-) - Body ground	20°C (68°F)	1 MΩ or higher

NG → **Go to step 3**

OK

2 CHECK WIRE HARNESS (TRANSMISSION WIRE - ECM)

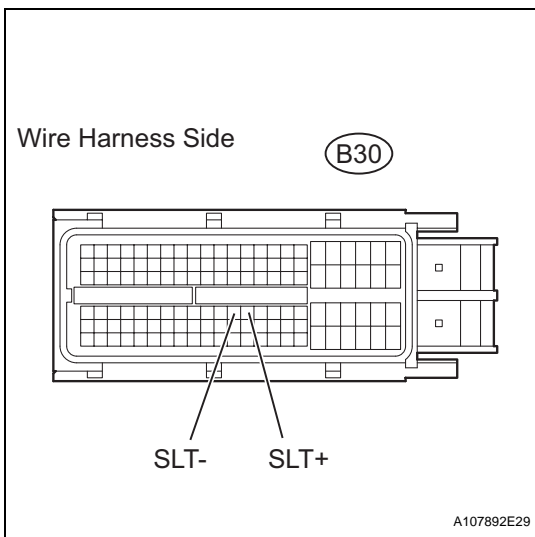

- (a) Disconnect the B30 ECM connector.
- (b) Measure the resistance of the wire harness side connector.

Standard resistance

Tester Connection	Condition	Specified Condition
B30-76 (SLT+) - B30-75 (SLT-)	20°C (68°F)	5.0 to 5.6 Ω
B30-76 (SLT+) - Body ground	20°C (68°F)	1 MΩ or higher
B30-75 (SLT-) - Body ground	20°C (68°F)	1 MΩ or higher

NG → **REPAIR OR REPLACE HARNESS AND CONNECTOR**

OK

REPLACE ECM

3 INSPECT SHIFT SOLENOID VALVE SLT

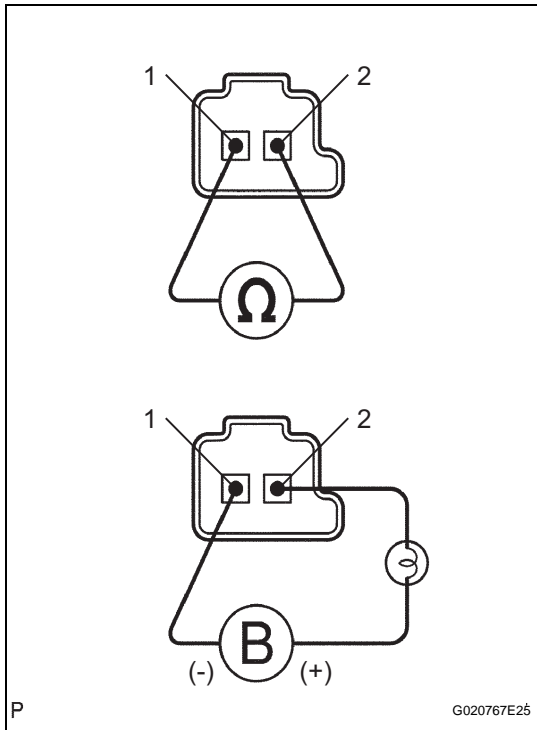

- (a) Remove the shift solenoid valve SLT.
- (b) Measure the resistance of the solenoid valve.
Standard resistance:
5.0 to 5.6 Ω at 20°C (68°F)
- (c) Connect the battery's positive (+) lead with a 21 W bulb to terminal 2 and the negative (-) lead to terminal 1 of the solenoid valve connector. Then check that the valve moves and makes an operating noise.

OK:

Valve moves and makes operating noise.

NG → **REPLACE SHIFT SOLENOID VALVE SLT**

OK

REPAIR OR REPLACE TRANSMISSION WIRE