

INSTALLATION

(2005/11-2006/01)

1. INSTALL SLIDING ROOF WEATHERSTRIP

(a) Install the sliding roof weatherstrip.

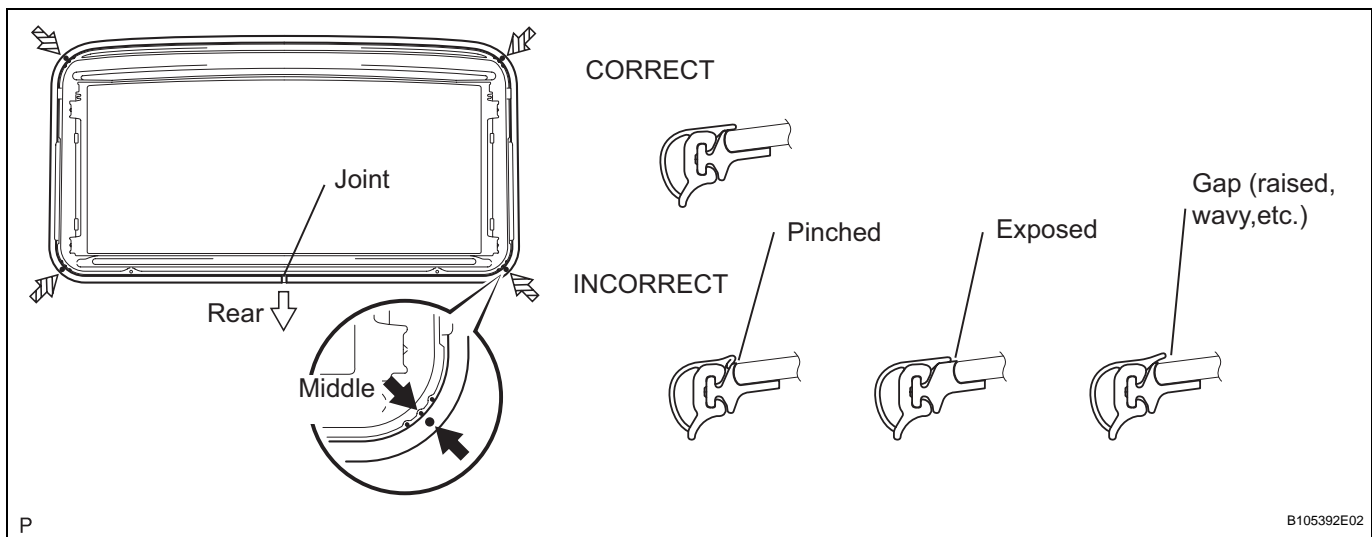

- (1) Position the joint of the weatherstrip at the rear center.
- (2) Align the marks on the weatherstrip with the middle marks at the corners of the plastic on the edge of the sliding roof panel and install the weatherstrip. Make sure that the marks on the weatherstrip are positioned within the area indicated by the marks at the corners of the plastic on the edge of the sliding roof panel.
- (3) Install the lip of the weatherstrip firmly.

2. INSTALL SLIDING ROOF HOUSING ASSEMBLY

(a) Install the housing with the 4 bolts and 8 nuts.

Torque: 5.4 N*m (55 kgf*cm, 48 in.*lbf)

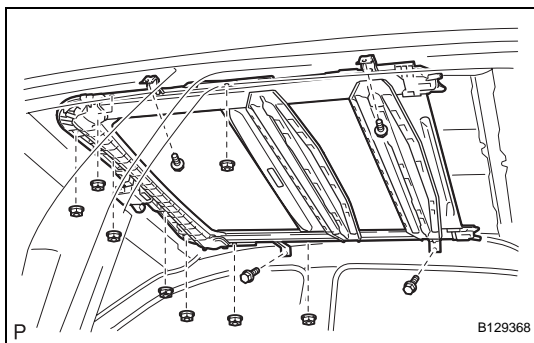

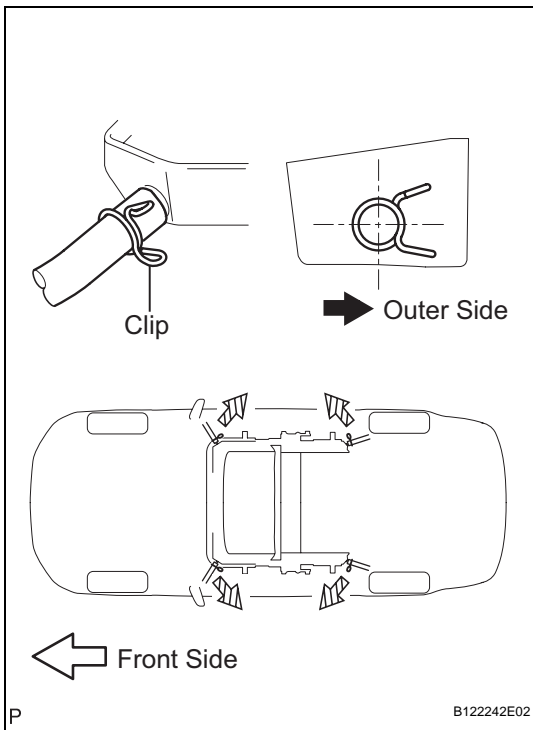

3. CONNECT SLIDING ROOF DRAIN HOSE

- (a) Connect the 4 drain hoses.

NOTICE:

The clip must face toward the outside of the vehicle and also be above the lower surface of the sliding roof housing when installing the drain hoses.

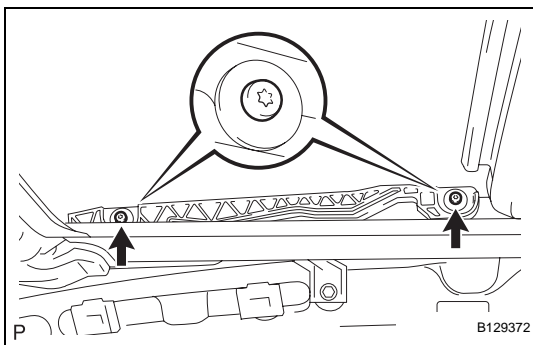

4. INSTALL SLIDING ROOF GLASS SUB-ASSEMBLY

- (a) Using a T25 "torx" driver, temporarily install the sliding roof glass sub-assembly with the 4 screws.

- (b) Perform a level check.

- (1) Check the difference in level for "a" between the roof panel and the upper surface of the weatherstrip when the sliding roof glass is fully closed.

Standard measurement

Area	Specified Condition
A - A	0 + 1.5 mm (0 + 0.059 in.) 0 - 1.5 mm (0 - 0.059 in.)
B - B	0 + 1.5 mm (0 + 0.059 in.) 0 - 1.5 mm (0 - 0.059 in.)
C - C	0 + 1.5 mm (0 + 0.059 in.) 0 - 1.5 mm (0 - 0.059 in.)
D - D	0 + 1.5 mm (0 + 0.059 in.) 0 - 1.0 mm (0 - 0.039 in.)

HINT:

"+" represents the condition that the glass is above the panel level. "-" represents the condition that the glass is below the panel level.

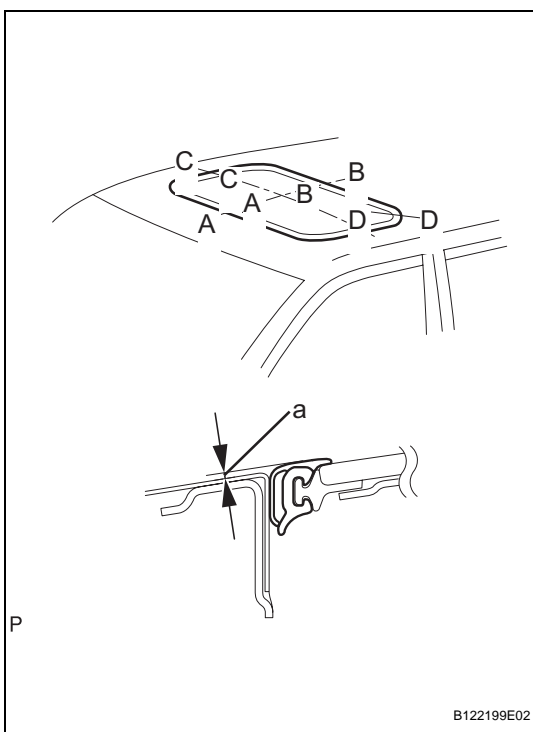

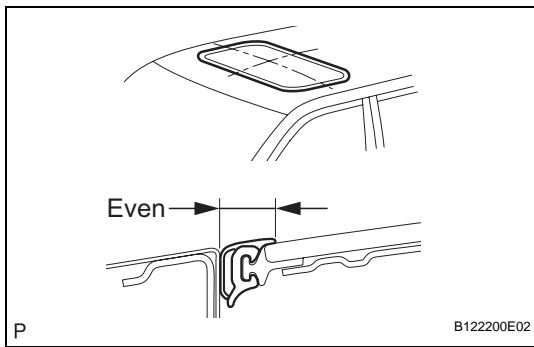

- (c) Perform a gap check.
 (1) Check the gap between the roof panel and roof glass.
NOTICE:
The gap must be even all around.

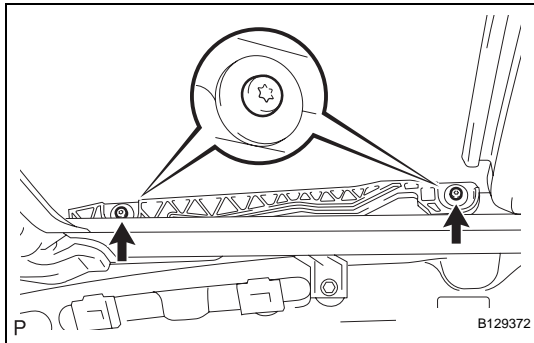

- (d) Using a T25 "torx" driver, install the sliding roof glass with the 4 screws.
Torque: 4.0 N*m (41 kgf*cm, 35 in.*lbf)

RF

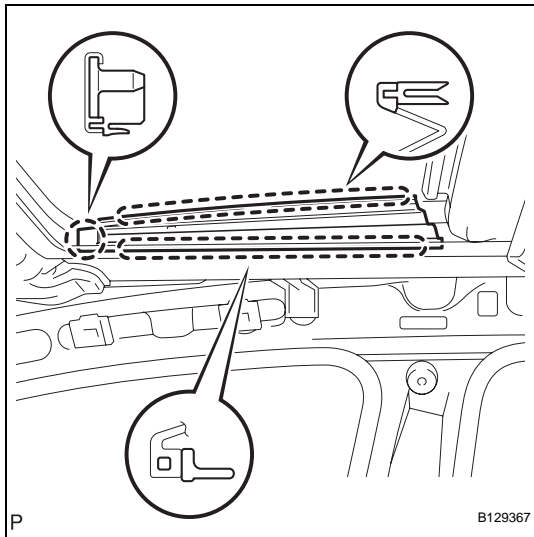

5. **INSTALL SLIDING ROOF SIDE GARNISH LH**
 (a) Attach the claws to install the garnish.
6. **INSTALL SLIDING ROOF SIDE GARNISH RH**
HINT:
 Use the same procedures described for the LH side.
7. **CHECK FOR WATER LEAKS**
 (a) Adjust the sliding roof glass sub-assembly, and check for water leaks.
 (b) If there are any leaks, readjust the sliding roof glass sub-assembly.
8. **INSTALL ROOF HEADLINING ASSEMBLY**
 (a) Install the roof headlining (see page [IR-49](#)).
9. **CONNECT CABLE TO NEGATIVE BATTERY TERMINAL**