

INSTALLATION

NOTICE:

Do not heat the vehicle body, emblem and name plate excessively.

HINT:

When installing the emblem and name plate, heat the vehicle body, emblem and name plate using a heat light.

Standard heating temperature

Item	Specified Condition
Vehicle body	40 to 60°C (104 to 140°F)
Name plate	20 to 30°C (68 to 86°F)

1. INSTALL NO. 4 BACK DOOR NAME PLATE (for 4WD)

- (a) Clean the vehicle body surface.
 - (1) Using a heat light, heat the vehicle body surface.
 - (2) Remove the double-sided tape from the vehicle body.
 - (3) Wipe off any tape adhesive residue with cleaner.
- (b) If reusing the name plate:

Clean the name plate.

 - (1) Using a heat light, heat the name plate.
 - (2) Remove the double-sided tape from the name plate.
 - (3) Wipe off any tape adhesive residue with cleaner.
 - (4) Apply new double-sided tape to the name plate.
- (c) Install the name plate.
 - (1) Using a heat light, heat the vehicle body and name plate.
 - (2) Remove the peeling paper from the face of the name plate.

HINT:

After removing the peeling paper, keep the exposed adhesive free from foreign matter.

- (3) Install the name plate.

NOTICE:

Install the name plate exactly according to the specifications below.

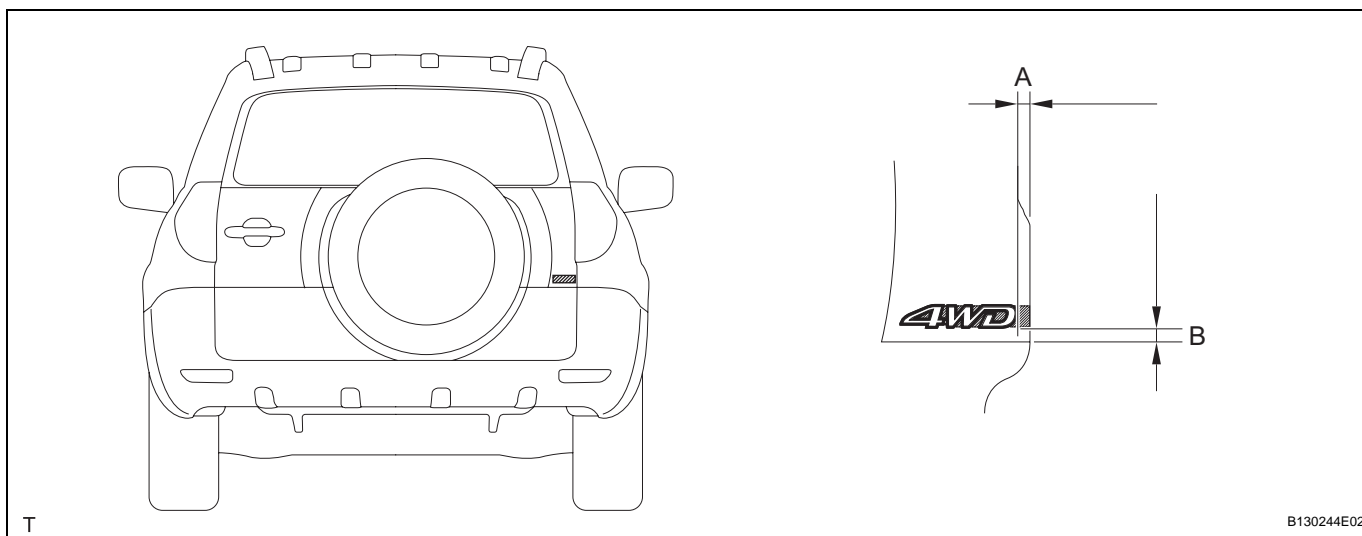

Standard measurement

Area	Specified Condition
A	8 mm (0.314 in.)
B	8.6 mm (0.338 in.)

2. INSTALL NO. 1 BACK DOOR EMBLEM

3. INSTALL BACK DOOR NAME PLATE

4. INSTALL NO. 1 BACK DOOR EMBLEM ASSEMBLY

- (a) Clean the vehicle body surface.
 - (1) Using a heat light, heat the vehicle body surface.
 - (2) Remove the double-sided tape from the vehicle body.
 - (3) Wipe off any tape adhesive residue with cleaner.
- (b) If reusing the name plate and emblem:

Clean the name plate and emblem.

 - (1) Using a heat light, heat the name plate and emblem.
 - (2) Remove the double-sided tape from the name plate and emblem.
 - (3) Wipe off any tape adhesive residue with cleaner.
 - (4) Apply new double-sided tape to the name plate and emblem.
- (c) Install the name plate and emblem.
 - (1) Using a heat light, heat the vehicle body, name plate and emblem.
 - (2) Remove the peeling paper from the face of the name plate and emblem.

HINT:

After removing the peeling paper, keep the exposed adhesive free from foreign matter.

- (3) Install the name plate and emblem.

NOTICE:

Install the name plate and emblem exactly according to the specifications below.

ET

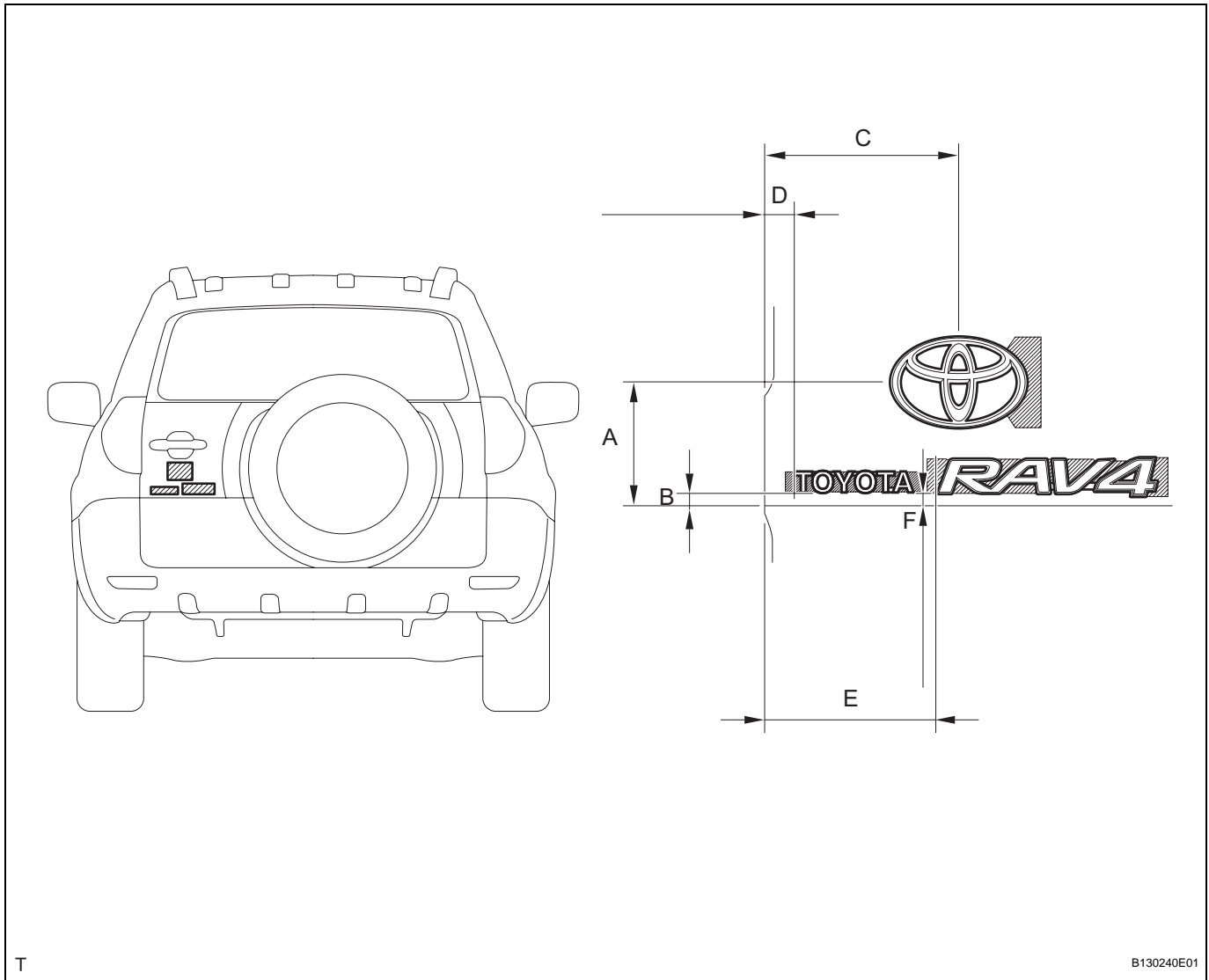

Standard measurement

Area	Specified Condition
A	92.8 mm (3.653 in.)
B	9.3 mm (0.366 in.)
C	157.5 mm (6.200 in.)
D	25.3 mm (0.996 in.)
E	138.0 mm (5.433 in.)
F	8.2 mm (0.322 in.)