

REMOVAL

(2006/01-)

1. **REMOVE FRONT WHEEL**
2. **DRAIN AUTOMATIC TRANSAXLE FLUID**
 - (a) Drain the automatic transaxle fluid for U140F (see page [AX-147](#)).
 - (b) Drain the automatic transaxle fluid for U241E (see page [AX-146](#)).
 - (c) Drain the automatic transaxle fluid for U151F (see page [AX-173](#)).
3. **REMOVE FRONT AXLE HUB NUT (See page [AH-8](#))**
4. **DISCONNECT FRONT SPEED SENSOR LH (See page [BC-191](#))**
5. **DISCONNECT FRONT SPEED SENSOR RH**
HINT:
Use the same procedures described for the LH side.
6. **DISCONNECT FRONT DISC BRAKE CYLINDER ASSEMBLY LH (See page [BR-40](#))**
7. **DISCONNECT FRONT DISC BRAKE CYLINDER ASSEMBLY RH**
HINT:
Use the same procedures described for the LH side.
8. **DISCONNECT FRONT STABILIZER LINK ASSEMBLY LH (See page [SP-30](#))**
9. **DISCONNECT FRONT STABILIZER LINK ASSEMBLY RH**
10. **DISCONNECT FRONT SUSPENSION LOWER NO. 1 ARM SUB-ASSEMBLY LH (See page [SP-22](#))**
11. **DISCONNECT FRONT SUSPENSION LOWER NO. 1 ARM SUB-ASSEMBLY RH**
HINT:
Use the same procedures described for the LH side.
12. **DISCONNECT STEERING KNUCKLE WITH AXLE HUB LH**
 - (a) Put matchmarks on the drive shaft and axle hub.
NOTICE:
Do not punch the marks.
 - (b) Using a plastic-faced hammer, disconnect the steering knuckle with axle hub.
NOTICE:
Be careful not to damage the boot and speed sensor rotor.
Do not excessively push out the drive shaft from the axle assembly.
13. **DISCONNECT STEERING KNUCKLE WITH AXLE HUB RH**
HINT:
Use the same procedures described for the LH side.

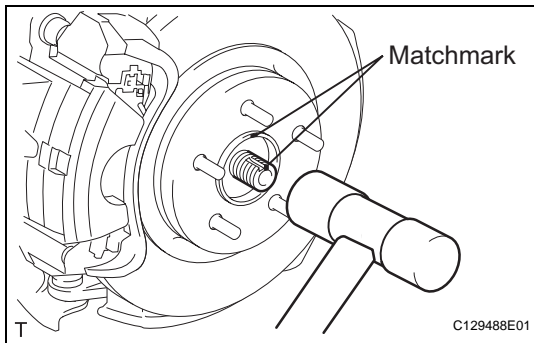

14. DISCONNECT TIE ROD END SUB-ASSEMBLY LH
(See page [PS-42](#))**15. DISCONNECT TIE ROD END SUB-ASSEMBLY RH**

HINT:

Use the same procedures described for the LH side.

16. REMOVE FRONT DRIVE SHAFT ASSEMBLY LH

- (a) Using SST, remove the front drive shaft.

SST 09520-01010, 09520-24010 (09520-32040)**NOTICE:**

- Be careful not to damage the transaxle case oil seal, inboard joint boot and drive shaft dust cover.
- Be careful not to drop the drive shaft.

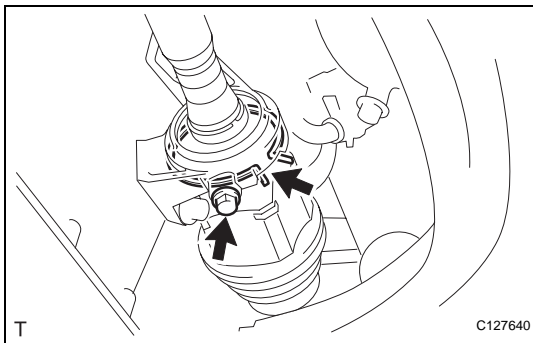
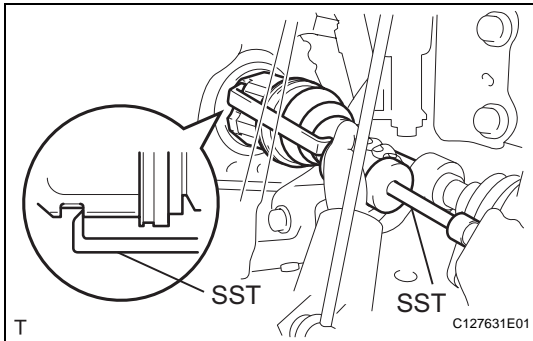
**17. REMOVE FRONT DRIVE SHAFT ASSEMBLY RH**

- (a) Squeeze the ends of the snap ring, and remove the snap ring from the bearing bracket.

- (b) Remove the bearing bracket bolt and remove the front drive shaft from the bearing bracket.

NOTICE:

- Do not damage the oil seal.
- Do not damage the boot.
- Do not allow the drive shaft to fall off.

HINT:

If the connection is stiff, use a brass bar and hammer to lightly tap the edge of the inboard joint RH and remove it.

18. FIX FRONT AXLE ASSEMBLY**NOTICE:**

The hub bearing could be damaged if it is subjected to the vehicle weight, such as when moving the vehicle with the drive shaft removed. Therefore, if it is absolutely necessary to place the vehicle weight on the hub bearing, first support it with SST.

SST 09608-16042 (09608-02021, 09608-02041)