

## DIAGNOSIS SYSTEM

### 1. DESCRIPTION

Power door lock control system data can be read in the Data Link Connector 3 (DLC3) of the vehicle. When the system seems to be malfunctioning, use the intelligent tester to check for malfunctions and perform repairs.

### 2. CHECK DLC3

- (a) The ECU uses ISO 15765-4 for communication. The terminal arrangement of the DLC3 complies with ISO 15031-3 and matches the ISO 15765-4 format.

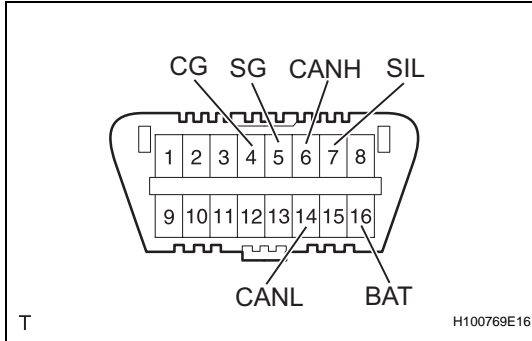

Symbols (Terminal No.)	Terminal Description	Condition	Specified Condition
SIL (7) - SG (5)	Bus '+' line	During transmission	Pulse generation
CG (4) - Body ground	Chassis ground	Always	Below 1 $\Omega$
SG (5) - Body ground	Signal ground	Always	Below 1 $\Omega$
BAT (16) - Body ground	Battery positive	Always	10 to 14 V
CANH (6) - CANL (14)	HIGH-level CAN bus line	Ignition switch OFF*	54 to 69 $\Omega$
CANH (6) - CG (4)	HIGH-level CAN bus line	Ignition switch OFF*	1 k $\Omega$ or more
CANL (14) - CG (4)	HIGH-level CAN bus line	Ignition switch OFF*	1 k $\Omega$ or more
CANH (6) - BAT (16)	LOW-level CAN bus line	Ignition switch OFF*	1 M $\Omega$ or more
CANL (14) - BAT (16)	LOW-level CAN bus line	Ignition switch OFF*	1 M $\Omega$ or more

#### NOTICE:

\*: Before measuring the resistance, leave the vehicle for at least 1 minute and do not operate the ignition switch, any switches or doors. If the result is not as specified, the DLC3 may have a malfunction. Repair or replace the harness and connector.

#### HINT:

Connect the cable of the intelligent tester to the DLC3, turn the ignition switch ON and attempt to use the tester. If the display indicates that a communication error has occurred, there is a problem either with the vehicle or with the tester.

- If communication is normal when the tester is connected to another vehicle, inspect the DLC3 of the original vehicle.
- If communication is still not possible when the tester is connected to another vehicle, the problem may be in the tester itself. Consult the Service Department listed in the tester's instruction manual.

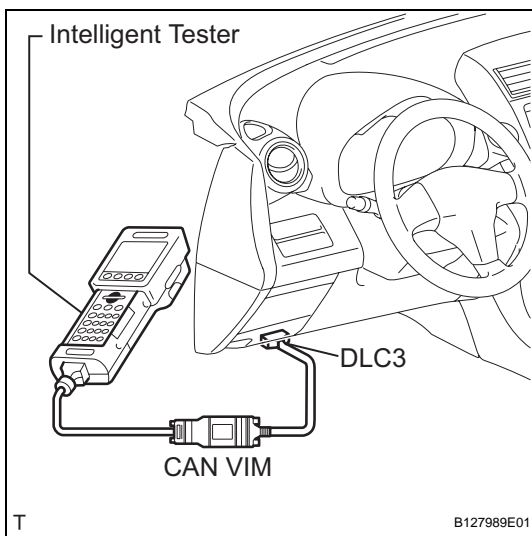

## DATA LIST / ACTIVE TEST

### 1. READ DATA LIST

#### HINT:

Using the intelligent tester's DATA LIST allows switch, sensor, actuator and other item values to be read without removing any parts. Reading the DATA LIST early in troubleshooting is one way to save time.

- (a) Connect the intelligent tester (with CAN VIM) to the DLC3.
- (b) Turn the ignition switch ON.
- (c) Read the DATA LIST on the tester's screen.

### Main body ECU

Item	Measurement Item / Display (Range)	Normal Condition	Diagnostic Note
D DOR CTY SW	Driver side door courtesy light switch signal / ON or OFF	ON: Driver side door is open OFF: Driver side door is closed	-
D LOCK POS SW	Driver side door lock position switch signal / ON or OFF	ON: Driver side door is unlocked OFF: Driver side door is locked	-
D/L SW-LOCK	Door manual lock switch signal ON or OFF	ON: Door control switch on power window regulator master switch is pushed to lock position OFF: Door control switch on power window regulator master switch is not pushed	-
D/L SW UNLOCK	Door manual unlock switch signal / ON or OFF	ON: Door control switch on power window regulator master switch is pushed to unlock position OFF: Door control switch on power window regulator master switch is not pushed	-
DOR KEY SW-LOCK	Door key linked lock switch signal / ON or OFF	ON: Driver side door key cylinder is turned to lock position OFF: Driver side door key cylinder is not turned	-
D DOR KEY SW-UL	Door key linked lock switch signal / ON or OFF	ON: Driver side door key cylinder is turned to unlock position OFF: Driver side door key cylinder is not turned	-
P DOR CTY SW	Passenger side door courtesy light signal / ON or OFF	ON: Passenger side door is open OFF: Passenger side door is closed	-
P LOCK POS SW	Passenger side door lock position switch signal / ON or OFF	ON: Passenger side door is unlocked OFF: Passenger side door is locked	-
RR DOR CTY SW	Rear door RH courtesy light switch signal / ON or OFF	ON: Rear door RH is open OFF: Rear door RH is closed	-
RL DOR CTY SW	Rear door LH courtesy light switch signal / ON or OFF	ON: Rear door LH is open OFF: Rear door LH is closed	-
BK DOR CTY SW	Back door courtesy light switch signal / ON or OFF	ON: Back door is open OFF: Back door is closed	-
KEY UNLK WRN SW	Unlock warning switch signal / ON or OFF	ON: Key is in ignition key cylinder OFF: No key is in ignition key cylinder	-

**2. PERFORM ACTIVE TEST****HINT:**

Performing the intelligent tester's ACTIVE TEST allows relay, VSV, actuator and other items to be operated without removing any parts. Performing the ACTIVE TEST early in troubleshooting is one way to save time. The DATA LIST can be displayed during the ACTIVE TEST.

- (a) Connect the intelligent tester (with CAN VIM) to the DLC3.
- (b) Turn the ignition switch ON.
- (c) Perform the ACTIVE TEST according to the display on the tester.

**Main body ECU**

Item	Test Details	Diagnostic Note
DOOR LOCK	Operate door lock motor LOCK/UNLOCK	-
D DOOR UNLOCK	Operate driver side door unlock ON / OFF	-