

INSTALLATION

(2006/01-)

1. **INSTALL CHECK VALVE GROMMET**
 - (a) Install the grommet to the booster.
2. **INSTALL BRAKE VACUUM CHECK VALVE ASSEMBLY**
 - (a) Install the check valve to the grommet.
3. **INSTALL BRAKE BOOSTER GASKET**
 - (a) Install a new gasket to the booster.
4. **INSTALL BRAKE MASTER CYLINDER PUSH ROD CLEVIS**
 - (a) Install the push rod clevis to the booster.
 - (b) Temporarily tighten the push rod clevis lock nut.

HINT:
The push rod clevis lock nut will be tightened to a torque specification in the "CHECK AND ADJUST BRAKE PEDAL HEIGHT" procedures.
5. **INSTALL BRAKE BOOSTER ASSEMBLY**
 - (a) Install the booster with the 4 nuts.
Torque: 12.7 N*m (130 kgf*cm, 9 ft.*lbf)
6. **INSTALL PUSH ROD PIN**

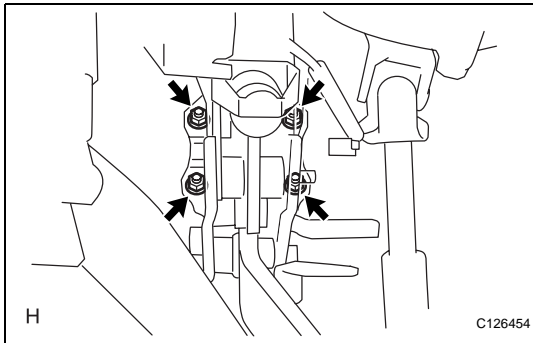

BR

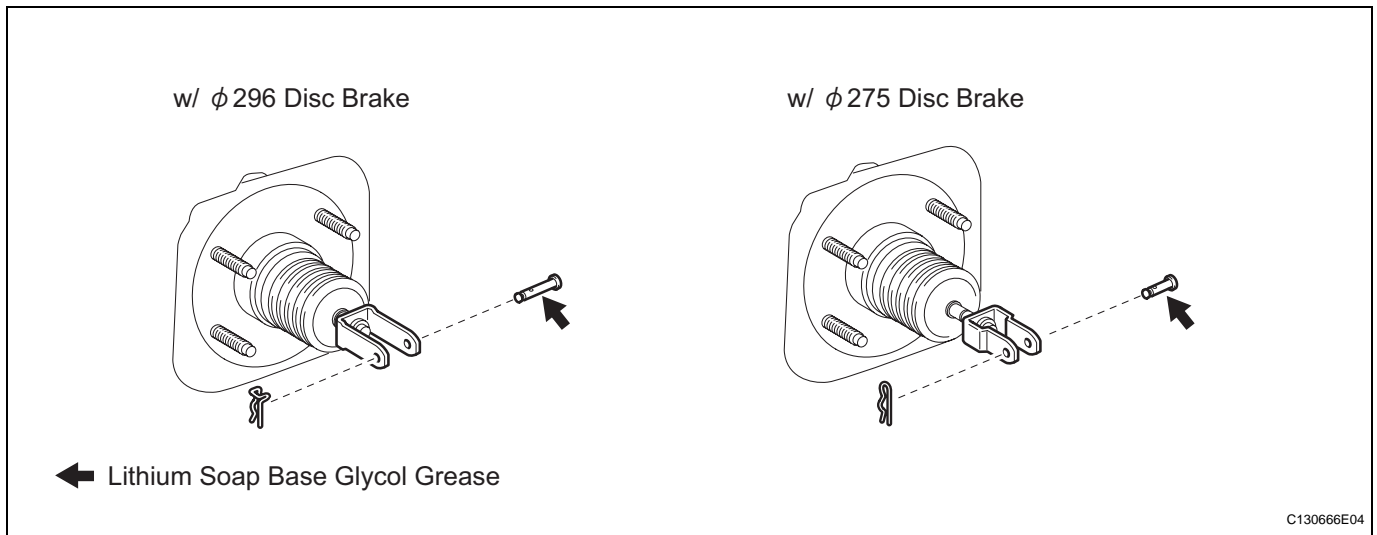

- (a) Apply lithium soap base glycol grease to the push rod pin.
 - (b) Install the push rod pin to the push rod clevis.
- NOTICE:**
The push rod pin must be installed as shown in the illustration.

- (c) Install the clip to the push rod pin.

NOTICE:

The clip must be installed as shown in the illustration.

7. **CHECK AND ADJUST BRAKE BOOSTER PUSH ROD**
(See page [BR-24](#))
8. **CONNECT VACUUM HOSE**
 - (a) Connect the vacuum hose to the check valve.
9. **INSTALL BRAKE MASTER CYLINDER SUB-ASSEMBLY** (See page [BR-26](#))
10. **INSTALL ABS AND TRACTION ACTUATOR ASSEMBLY WITH BRACKET** (See page [BC-187](#))
11. **CONNECT BRAKE LINES** (See page [BC-188](#))
12. **FILL RESERVOIR WITH BRAKE FLUID** (See page [BR-6](#))
13. **BLEED AIR FROM BRAKE MASTER CYLINDER** (See page [BR-7](#))
14. **BLEED AIR FROM BRAKE LINE** (See page [BR-7](#))
15. **BLEED AIR FROM ABS AND TRACTION ACTUATOR ASSEMBLY** (See page [BR-8](#))
16. **CHECK AND ADJUST BRAKE PEDAL HEIGHT** (See page [BR-15](#))
17. **CHECK BRAKE PEDAL FREE PLAY** (See page [BR-15](#))
18. **CHECK BRAKE PEDAL RESERVE DISTANCE** (See page [BR-16](#))
19. **CHECK BRAKE FLUID LEVEL IN RESERVOIR** (See page [BR-6](#))
20. **CHECK FOR BRAKE FLUID LEAKAGE**
21. **INSTALL AIR CLEANER CASE SUB-ASSEMBLY (for 2AZ-FE)**
 - (a) Install the air cleaner case (see page [EM-105](#)).
HINT:
Refer to the procedures from the installation of the air cleaner case up until the installation of the purge VSV.
22. **INSTALL AIR CLEANER CASE (for 2GR-FE)**
 - (a) Install the air cleaner case (see page [EM-31](#)).
HINT:
Refer to the procedures from the installation of the air cleaner case up until the installation of the air cleaner cap sub-assembly.