

COMPRESSOR AND PULLEY (for 2GR-FE)

COMPONENTS

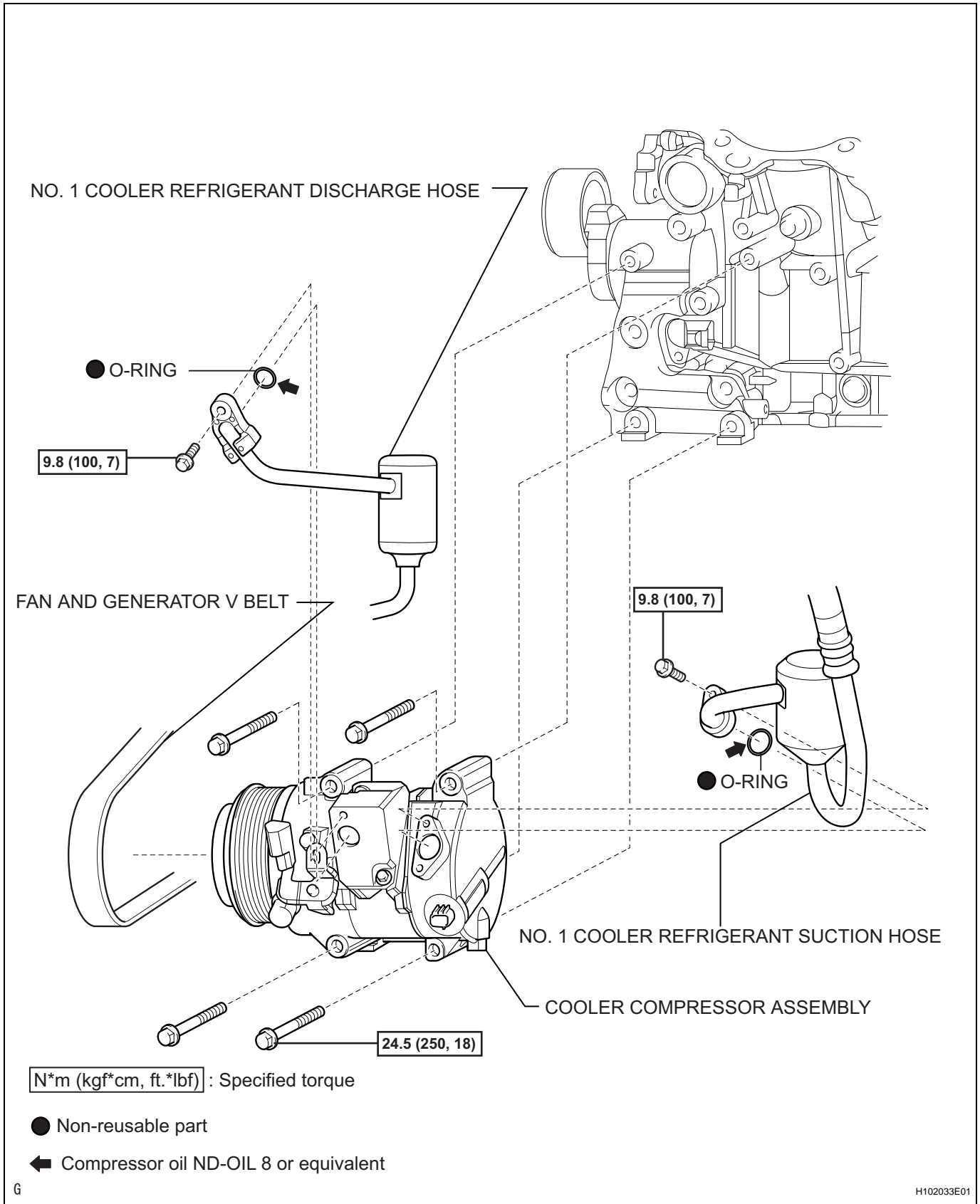

AC

REMOVAL

1. DISCHARGE REFRIGERANT FROM REFRIGERATION SYSTEM (See page [AC-172](#))

2. DISCONNECT CABLE FROM NEGATIVE BATTERY TERMINAL

CAUTION:

Wait at least 90 seconds after disconnecting the cable from the negative (-) battery terminal to prevent airbag and seat belt pretensioner activation.

3. DISCONNECT NO. 1 COOLER REFRIGERANT SUCTION HOSE

- (a) Remove the bolt and disconnect the cooler refrigerant suction hose from the cooler compressor.
- (b) Remove the O-ring from the cooler refrigerant suction hose.

NOTICE:

Seal the openings of the disconnected parts using vinyl tape to prevent moisture and foreign matter from entering them.

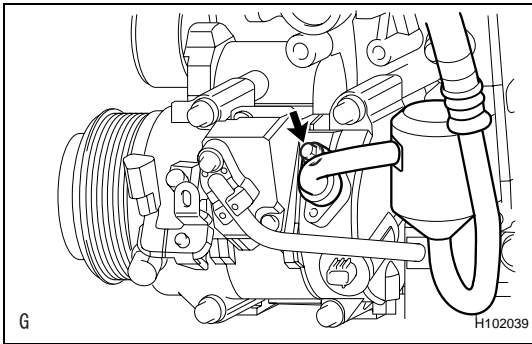

4. DISCONNECT NO. 1 COOLER REFRIGERANT DISCHARGE HOSE

- (a) Remove the bolt and disconnect the cooler refrigerant discharge hose from the cooler compressor.
- (b) Remove the O-ring from the cooler refrigerant discharge hose.

NOTICE:

Seal the openings of the disconnected parts using vinyl tape to prevent moisture and foreign matter from entering them.

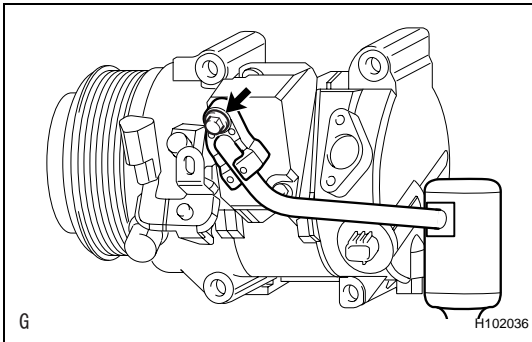

5. REMOVE FAN AND GENERATOR V BELT (See page [EM-8](#))

6. REMOVE COOLER COMPRESSOR ASSEMBLY

- (a) Disconnect the connector.
- (b) Remove the 4 bolts and cooler compressor.

