

REMOVAL

1. **DISCHARGE FUEL SYSTEM PRESSURE** (See page [FU-13](#))
2. **DISCONNECT CABLE FROM NEGATIVE BATTERY TERMINAL**
CAUTION:
 Wait at least 90 seconds after disconnecting the cable from the negative (-) battery terminal to prevent airbag and seat belt pretensioner activation.
3. **REMOVE FUEL TANK CAP**
4. **REMOVE FRONT FLOOR COVER**
 (a) Remove the nut, bolt, 3 clips and floor cover.
5. **REMOVE NO. 1 FLOOR UNDER COVER**
 (a) Remove the 2 nuts, clip and floor under cover.

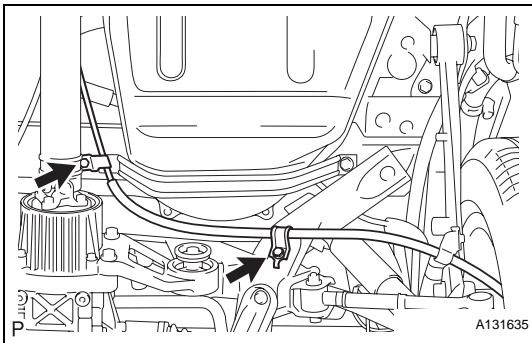
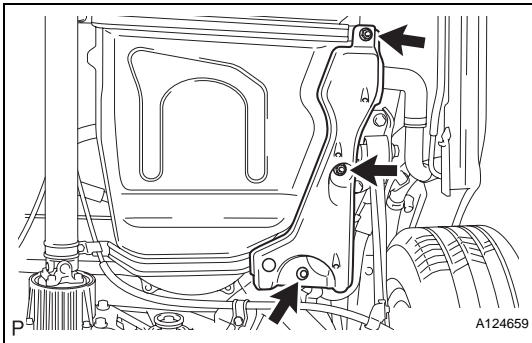

6. **DISCONNECT NO. 2 PARKING BRAKE CABLE ASSEMBLY**
 (a) Remove the 2 bolts and disconnect the parking brake cable.

FU

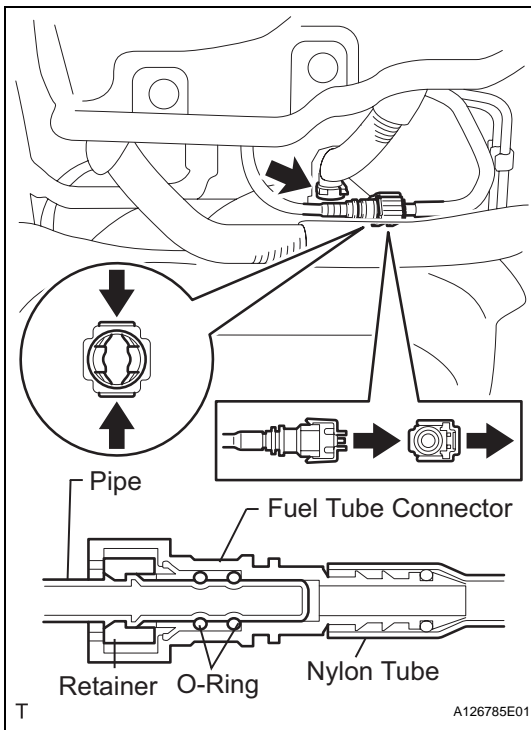

7. DISCONNECT FUEL TANK MAIN TUBE SUB-ASSEMBLY

- (a) Pinch and pull the main tube connector to disconnect the connector from the pipe.

NOTICE:

- Check for foreign matter in the pipe and around the connector. Clean if necessary. Foreign matter may damage the O-ring or cause leaks in the seal between the pipe and connector.
- Do not use any tools to separate the pipe and connector.
- Do not forcefully bend or twist the nylon tube.
- Check for foreign matter on the pipe seal surface. Clean if necessary.
- Put the pipe and connector ends in plastic bags to prevent damage and foreign matter contamination.
- If the pipe and connector are stuck together, pinch the connector between your fingers and turn it carefully to disconnect it.

- (b) Disconnect the EVAP hose from the tank.

8. DISCONNECT FUEL TANK TO FILLER PIPE HOSE

- (a) Disconnect the filler pipe hose from the fuel tank.

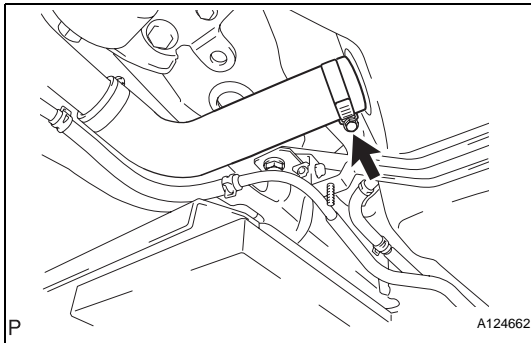

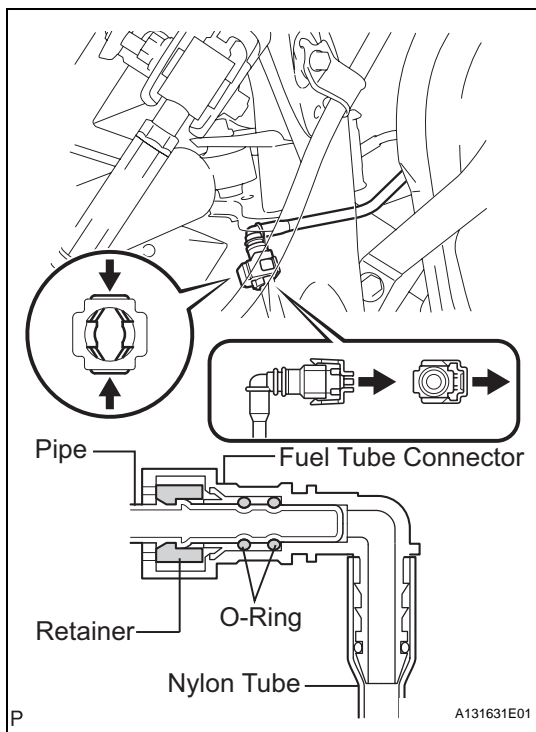

9. DISCONNECT FUEL TANK BREATHER HOSE

- (a) Disconnect the breather hose from the fuel tank.

NOTICE:

- Check for foreign matter in the pipe and around the connector. Clean if necessary. Foreign matter may damage the O-ring or cause leaks in the seal between the pipe and connector.
- Do not use any tools to separate the pipe and connector.
- Do not forcefully bend or twist the nylon tube.
- Check for foreign matter on the pipe seal surface. Clean if necessary.
- Put the pipe and connector ends in plastic bags to prevent damage and foreign matter contamination.
- If the pipe and connector are stuck together, pinch the connector between your fingers and turn it carefully to disconnect it.

10. REMOVE FUEL TANK FILLER PIPE

- (a) Remove the 3 bolts and filler pipe protector.
 (b) Remove the 2 bolts and filler pipe.

11. REMOVE FUEL TANK ASSEMBLY

- (a) Set a mission jack underneath the fuel tank.
 (b) Remove the 6 bolts and 3 fuel tank bands.
 (c) Slightly lower the mission jack.

NOTICE:

Be careful not to cut the wirings.

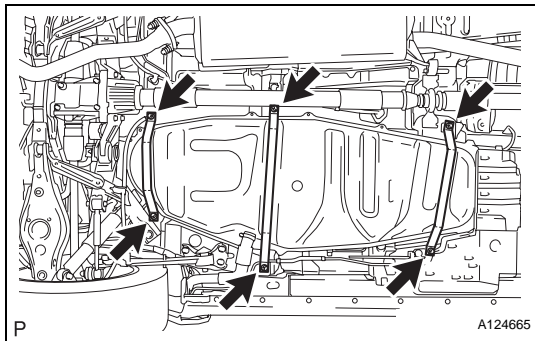

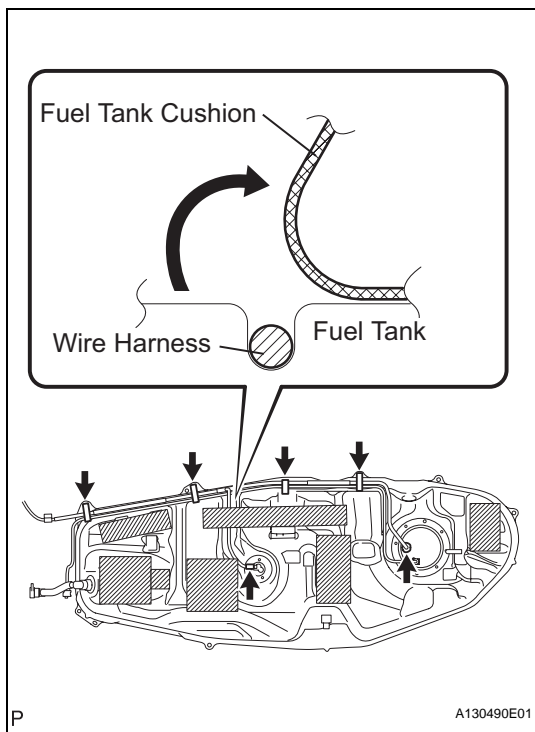

- (d) Fold back approximately half of each cushion rubber so that the wire harness can be detached from the fuel tank in the step below.
- (e) Disconnect the fuel pump connector and sender gauge connector.

NOTICE:

- Before this procedure, check the connector for dirt, mud or other contamination.
 - Do not use any tools in this procedure.
- (f) Detach the wire harness from the 4 clamps and remove the fuel tank.