

FUEL SYSTEM

PRECAUTION

1. BEFORE WORKING ON FUEL SYSTEM

- (a) Do not work near an open flame.
- (b) Keep gasoline away from rubber and leather parts.
- (c) Perform the "DISCHARGE FUEL SYSTEM PRESSURE" procedures below before disconnecting the fuel line to prevent gasoline from spilling out.

2. DISCHARGE FUEL SYSTEM PRESSURE

CAUTION:

- The "DISCHARGE FUEL SYSTEM PRESSURE" procedures must be performed before disconnecting any part of the fuel system.
- After performing the "DISCHARGE FUEL SYSTEM PRESSURE" procedures, pressure will remain in the fuel line. When disconnecting the fuel line, place a cloth or equivalent over fittings to reduce the risk of fuel spray.

- (a) Remove the console box (see page [IP-16](#)).
- (b) Disconnect the connector.
- (c) Start the engine. After the engine has stopped, turn the ignition switch OFF.
HINT:
DTC P0171/P0172 (system too lean) may be set.
- (d) Check that the engine does not start.
- (e) Remove the fuel tank cap, and let the air out of the fuel tank.

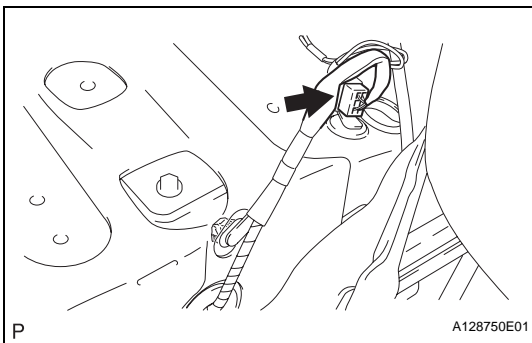
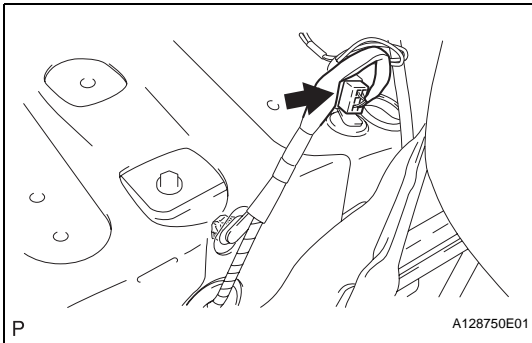

- (f) Connect the connector.
- (g) Install the console box (see page [IP-23](#)).

3. FUEL SYSTEM

- (a) When disconnecting the high fuel pressure line, a large amount of gasoline will spill out, so observe the following procedures:
 - (1) Discharge the fuel system pressure.
 - (2) Disconnect the fuel pump main tube (see page [FU-22](#)).
 - (3) Drain the fuel that remains inside the fuel pump main tube.

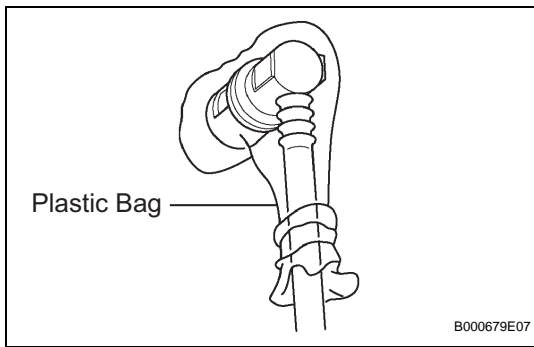

- (4) To protect the disconnected fuel pump main tube from damage and contamination, cover it with a plastic bag.
- (5) Put a container under the connection part.

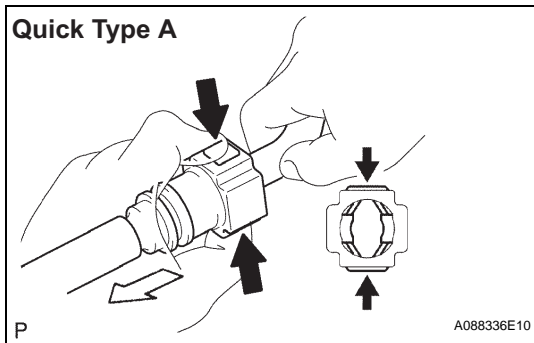

- (b) Observe the following precautions when disconnecting the fuel tube connectors (quick type A):

- (1) Remove the No. 1 fuel pipe clamp.

FU

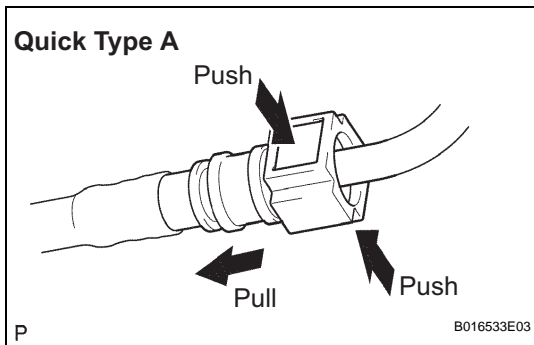

- (2) Check that there is no dirt or other foreign objects on the pipe and around the connector before disconnecting them. Clean them if necessary.
- (3) Disconnect the connector from the pipe by hand.
- (4) When the connector and the pipe are stuck, push in and pull on the connector to release it and pull the connector out of the pipe carefully.
- (5) Check that there is no dirt or other foreign objects on the sealing surface of the disconnected pipe. Clean it away if necessary.
- (6) Do not damage the disconnected pipe and connector, and prevent intrusion of foreign objects by covering them with a plastic bag.

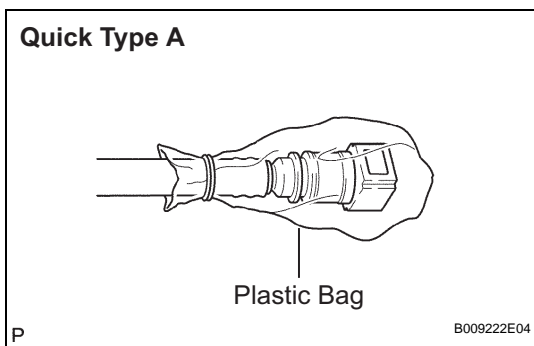

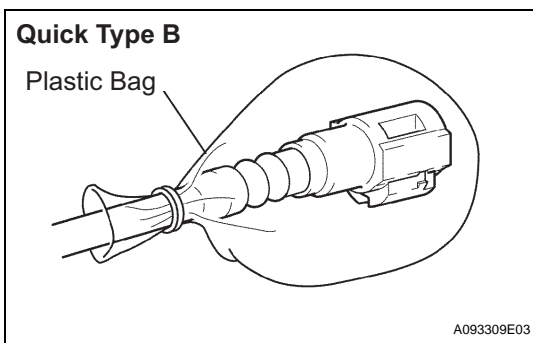
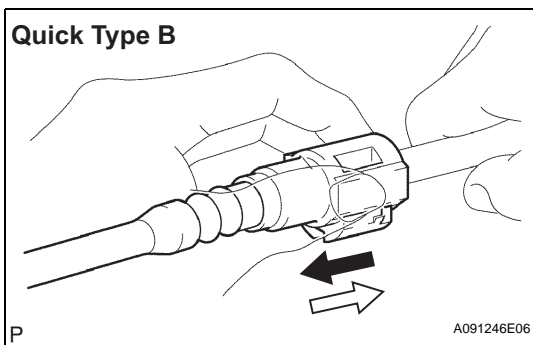
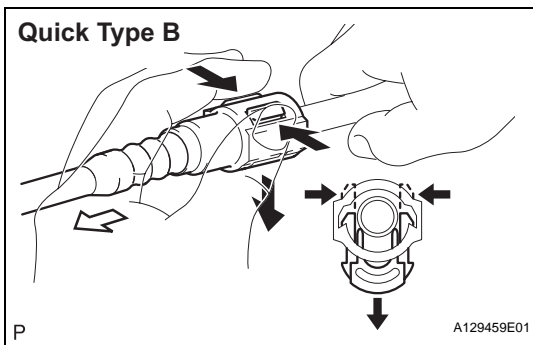
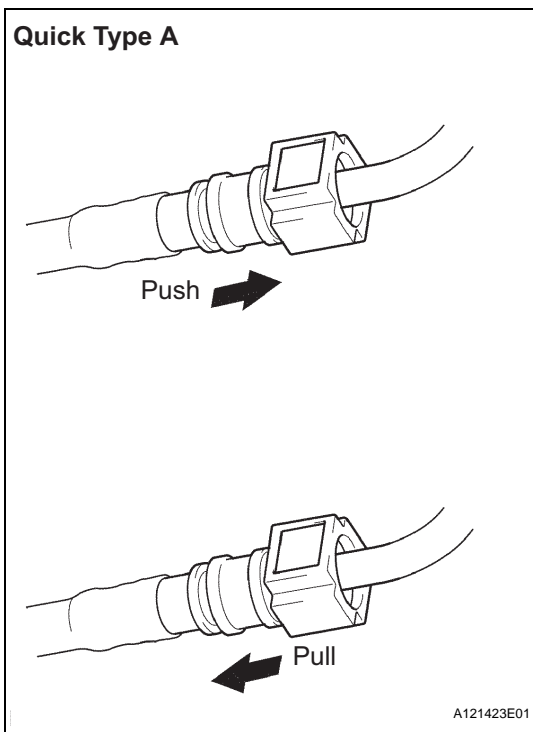

- (c) Observe the following precautions when connecting the fuel tube connectors (quick type A):
- (1) Check that there is no damage or foreign objects in the connected part of the pipe.
 - (2) Match the axis of the connector with the axis of the pipe, and push the pipe into the connector until the connector makes a "click" sound. If the connection is tight, apply a small amount of fresh engine oil to the tip of the pipe.
 - (3) After finishing the connection, check if the pipe and the connector are securely connected by pulling on them.
 - (4) Check for fuel leaks.

- (d) Observe the following precautions when disconnecting the fuel tube connector (quick type B):
- (1) Check that there is no dirt or other foreign objects around the connector before disconnecting the fuel pump tube.
 - (2) Detach the 2 claws of the connector retainer. Push down on the connector and disconnect it from the pipe.
HINT:
Be sure to disconnect the connector by hand.
 - (3) If the connector and pipe are stuck, pinch the fuel pipe by hand and push or pull on the connector to disconnect it.
 - (4) Check that there is no dirt or other foreign objects on the sealing surface of the disconnected pipe.

- (5) Do not damage the connector and pipe, and prevent intrusion of foreign objects by covering them with a plastic bag.

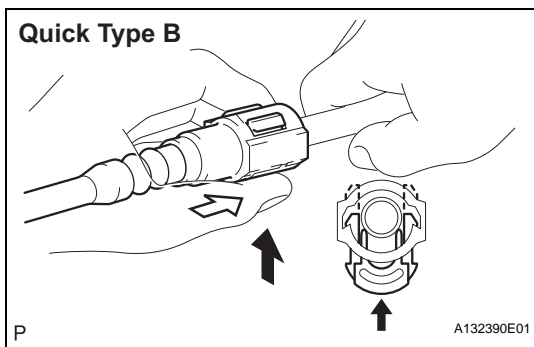

- (e) Observe the following precautions when disconnecting the fuel tube connector (quick type B):
- (1) Match the axis of the connector with the axis of the pipe. Push the pipe into the connector and push up on the retainer.
- HINT:
If it is hard to make the connection, apply a small amount of engine oil to the tip of the pipe.
- (2) After finishing the connection, pull on the connector and pipe and make sure that they are securely connected.
 - (3) Check for fuel leaks.
- (f) Observe the following precautions when handling a nylon tube:

CAUTION:

- Do not twist the connection part of the nylon tube and the quick connector when connecting them.
- Do not bend or twist the nylon tube.
- Do not remove the EPDM protector on the outside of the nylon tube.
- Do not close the piping by bending the nylon tube.

FU

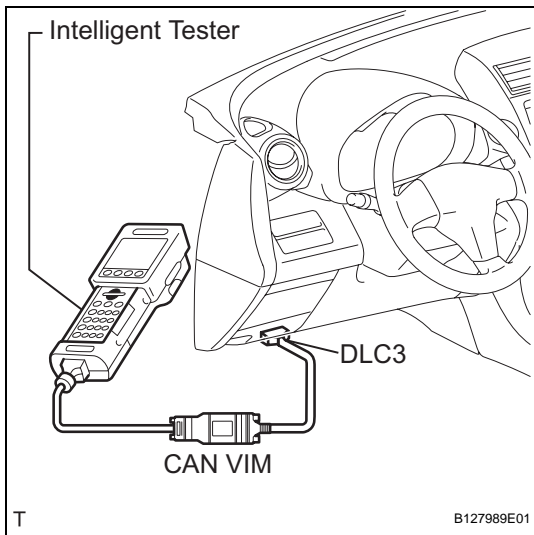
**4. CHECK FOR FUEL LEAKS**

- (a) Make sure that there are no fuel leaks after performing maintenance on the fuel system.
- (1) Connect the intelligent tester to the DLC3.
 - (2) Turn the ignition switch ON, and push the intelligent tester main switch ON.
- NOTICE:**
Do not start the engine.
- (3) Select the Active Test mode on the intelligent tester.
 - (4) Check that there are no leaks from the fuel system.
 - (5) Turn the ignition switch OFF.
 - (6) Disconnect the intelligent tester from the DLC3.