

GENERATOR COMPONENTS

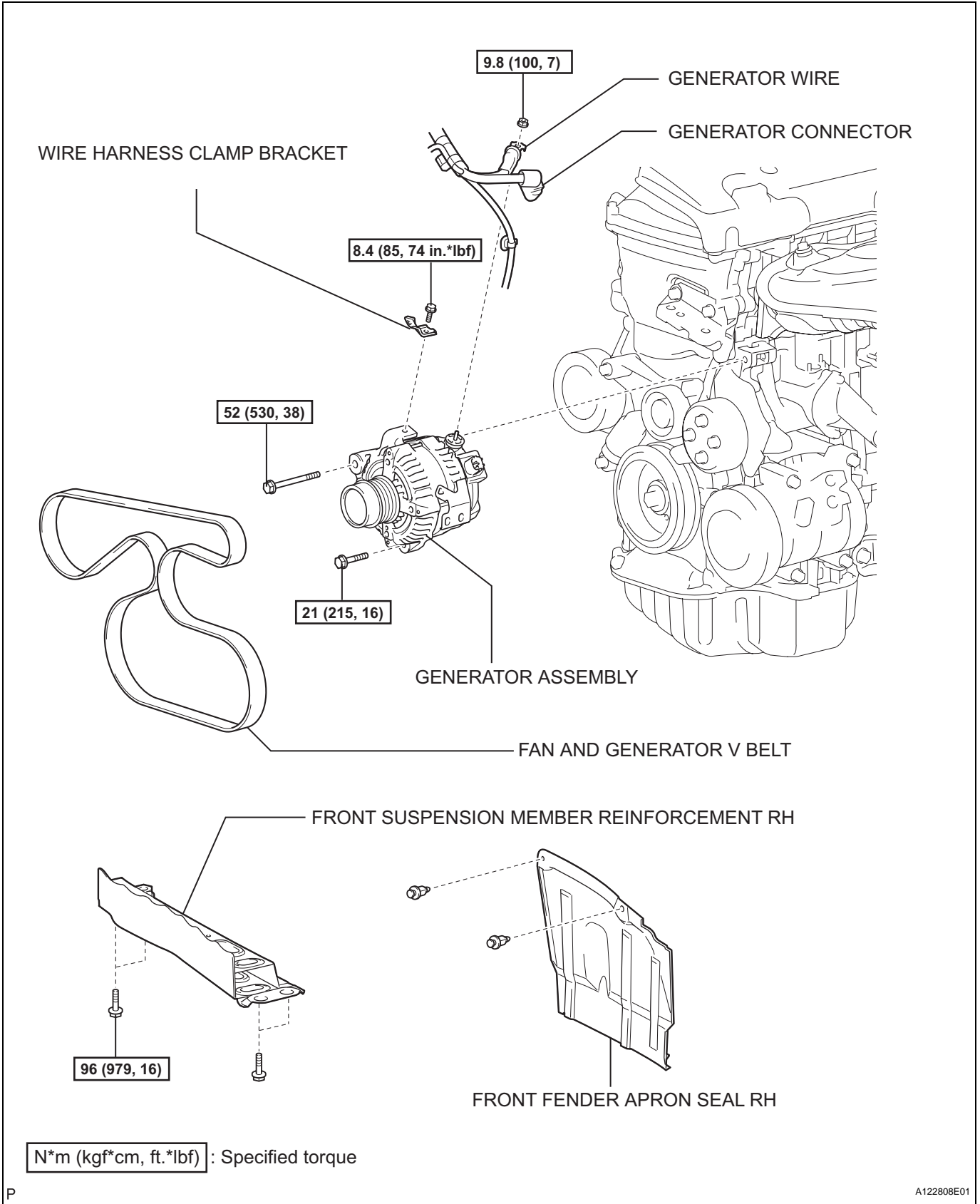

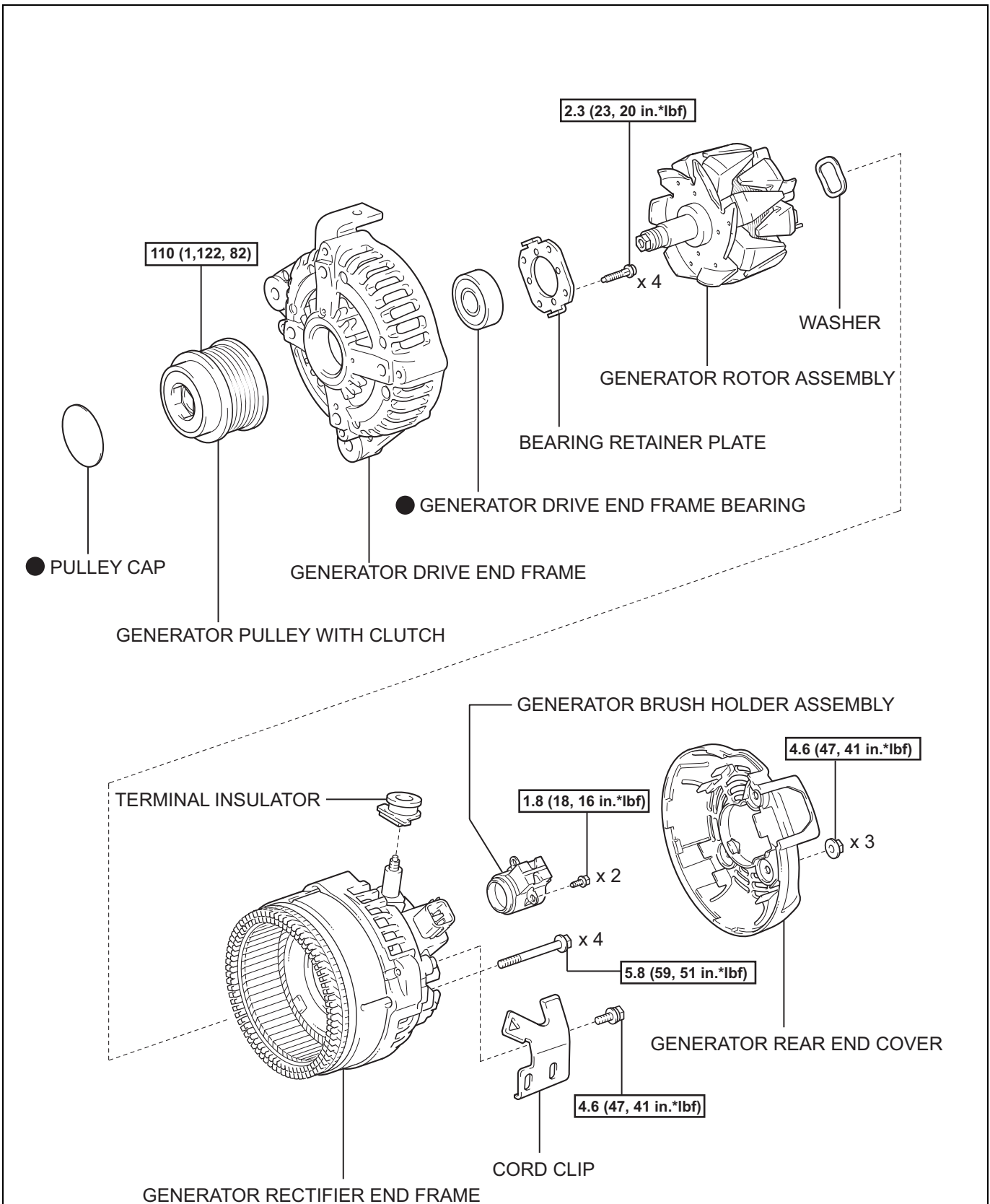

N*m (kgf*cm, ft.*lbf) : Specified torque

● Non-reusable part

CH