

## DISPOSAL

### HINT:

When scrapping vehicles equipped with a seat belt pretensioner or disposing of a front seat outer belt (with seat belt pretensioner), always first activate the seat belt pretensioner in accordance with the procedures described below. If any abnormality occurs during activation of the seat belt pretensioner, contact the SERVICE DEPARTMENT of TOYOTA MOTOR SALES, U.S.A., INC. When disposing of a front seat outer belt assy (with seat belt pretensioner) that was activated in a collision, start with step 1-(f) in this section.

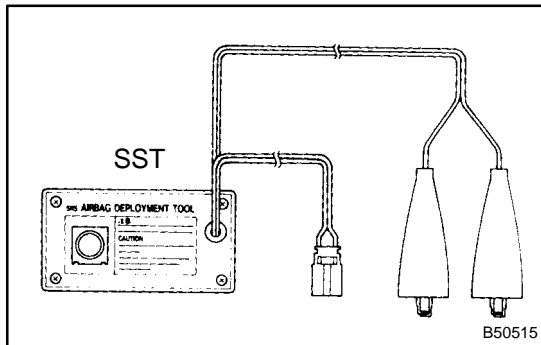

### CAUTION:

- Never dispose of a front seat outer belt assy that has an unactivated pretensioner.
- The seat belt pretensioner produces a loud, exploding sound when it activates. Perform the operation where it will not be a nuisance to nearby residents.
- When activating a front seat outer belt (with seat belt pretensioner), stand at least 10 m (33 ft) away from the front seat outer belt.
- Use gloves and safety glasses when handling a front seat belt with an activated pretensioner.
- Always wash your hands with water after completing activation.
- Do not apply water to a front seat outer belt that has an activated pretensioner.
- When activating the seat belt pretensioner, always use the specified SST (SRS airbag deployment tool).
- Perform operation in a place away from electrical interference.

SST 09082-00700

1. **DISPOSE OF FRONT SEAT OUTER BELT ASSY RH (WHEN INSTALLED IN VEHICLE)**

### HINT:

Prepare a battery to power activation of the seat belt pretensioner.

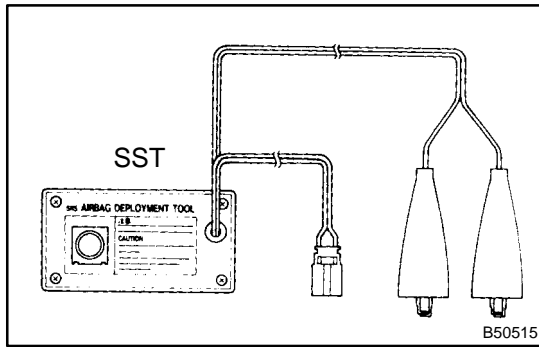

(a) Check if SST is functioning.

**CAUTION:**

**When activating the seat belt pretensioner, always use the specified SST.**

SST 09082-00700, 09082-00770

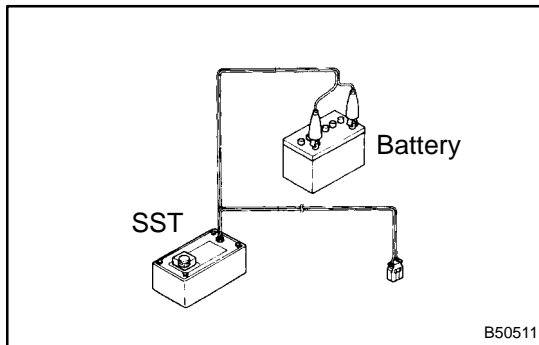

(1) Connect SST red clip to the battery's positive (+) terminal and the black clip to the negative (-) terminal.

**HINT:**

Do not connect the yellow connector. The yellow connector is used to connect to the seat belt pretensioner.

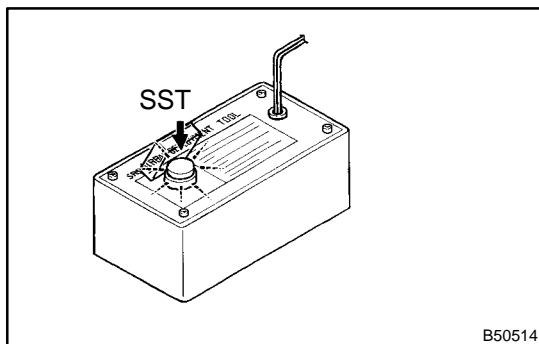

(2) Press SST activation switch and check that the LED of SST activation switch lights up.

**CAUTION:**

**If the LED turns on when the activation switch is not being pressed, SST may be malfunctioning. Do not use SST.**

(b) Disconnect SST from the battery.

(c) Disconnect the pretensioner connector.

(1) Disconnect the battery's negative (-) terminal.

(2) Remove the front door scuff plate RH (see page 76-28).

(3) Remove the rear door scuff plate RH (see page 76-28).

(4) Remove the front door opening trim weatherstrip RH (see page 76-28).

(5) Remove the rear door opening trim weatherstrip RH (see page 76-28).

(6) Remove the center pillar garnish lower RH (see page 76-28).

(7) Remove the center pillar garnish upper RH (see page 76-28).

## SEAT BELT – FRONT SEAT BELT

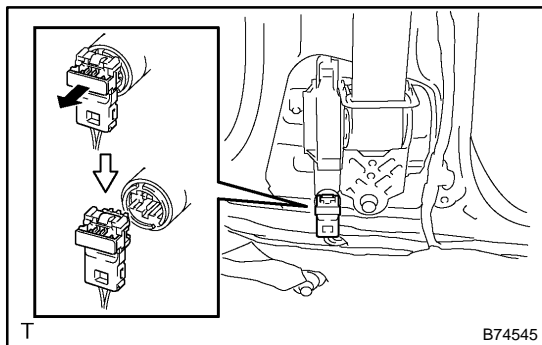

- (8) Disconnect the pretensioner connector, as shown in the illustration.
- (d) Connect the SST.
- (1) Install floor anchor of the seat belt.

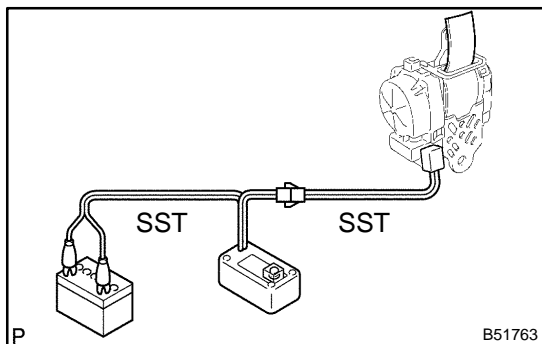

- (2) Connect 2 SSTs, then connect the yellow connector to the seat belt pretensioner.

SST 09082-00700, 09082-00770

**NOTICE:**

To avoid damaging SST connector and wire harness, do not lock the secondary lock of the twin lock.

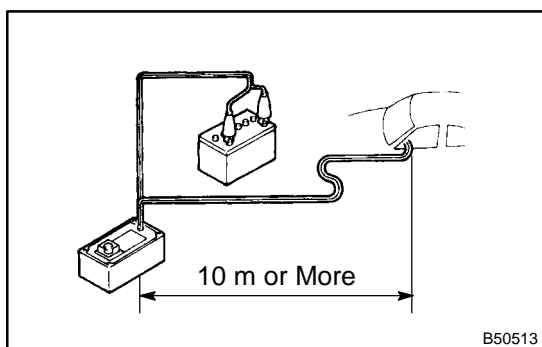

- (3) Move SST at least 10 m (33 ft) away from the front of the vehicle.
- (4) Close all the doors and windows of the vehicle.

**HINT:**

Do not close the windows fully. Leave a gap for inserting SST wire harness.

**NOTICE:**

Take care not to damage SST wire harness.

- (5) Connect SST red clip to the battery's positive (+) terminal and the black clip to the negative (-) terminal.
- (e) Activate the seat belt pretensioner.
- (1) Confirm that no one is inside the vehicle or within 10 m (33 ft) of the vehicle.
- (2) Press SST activation switch and activate the seat belt pretensioner.

**HINT:**

The seat belt pretensioner operates simultaneously with the LED light for SST activation switch.

- (f) Dispose of the outer belt (with the seat belt pretensioner).

**CAUTION:**

- Do not touch the outer belt for at least 30 minutes after the seat belt pretensioner has been activated. It is very hot.
- Use gloves and safety glasses when handling an outer belt with a pretensioner that has been activated.
- Always wash your hands with water after completing the operation.
- Do not apply water to a front seat outer belt that has an activated pretensioner.

**HINT:**

When scrapping a vehicle, activate the seat belt pretensioner, and then scrap the vehicle with the activated outer belt still installed.

## 2. DISPOSE OF FRONT SEAT OUTER BELT ASSY RH (WHEN NOT INSTALLED IN VEHICLE)

**NOTICE:**

- When only disposing of the front seat outer belt (with the seat belt pretensioner), never use the customer's vehicle to activate the seat belt pretensioner.
- Be sure to follow the procedures listed below when activating the seat belt pretensioner.

**HINT:**

Prepare a battery as the power source to activate the seat belt pretensioner.

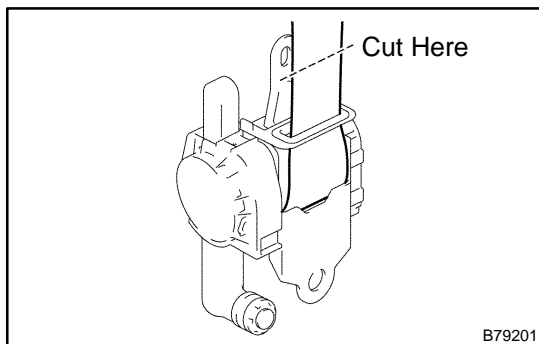

- (a) Remove the outer belt (see page 61-9).
- (1) Wind the seat belt with the retractor.
  - (2) When the seat belt is sufficiently wound, cut the seat belt approximately 10 cm from the retractor, as shown in the illustration.

**HINT:**

The amount of resistance in the retractor increases in correlation with how much the seat belt is wound.

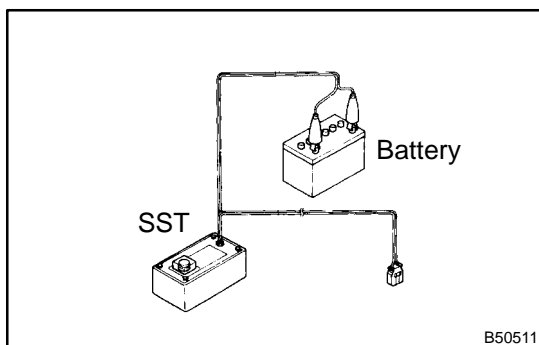

- (b) Check if SST is functioning (see step 1-(a)).

**CAUTION:**

When activating the seat belt pretensioner, always use the specified SST.

SST 09082-00700, 09082-00770

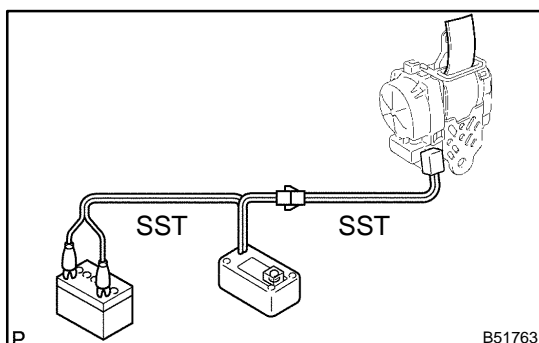

- (c) Connect SST.
- (1) Connect SST, then connect them to the seat belt pretensioner.

**NOTICE:**

To avoid damaging SST connector and wire harness, do not lock the secondary lock of the twin lock.

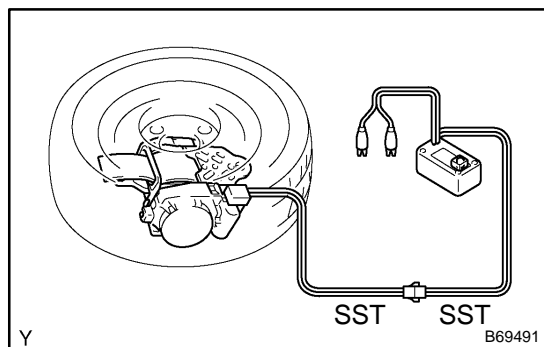

- (2) Place the outer belt on the ground and cover it with a tire with a wheel attached.

**NOTICE:**

Set up the front seat outer belt assy as shown in the illustration.

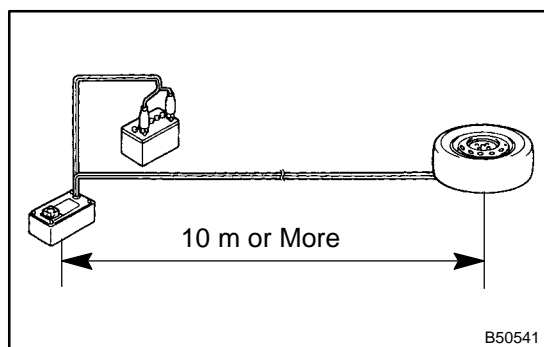

- (3) Move SST at least 10 m (33 ft) away from the wheel.

**NOTICE:**

Take care not to damage SST wire harness.

- (d) Activate the seat belt pretensioner.
- (1) Connect SST red clip to the battery's positive (+) terminal and the black clip to the battery's negative (-) terminal.
  - (2) Check that no one is within 10 m (33 ft) of the wheel.
  - (3) Press SST activation switch and activate the seat belt pretensioner.

**HINT:**

The seat belt pretensioner operates simultaneously with the LED light for SST activation switch.

- (e) Dispose of the outer belt (with the seat belt pretensioner).

**CAUTION:**

- Do not touch the outer belt for at least 30 minutes after the seat belt pretensioner has been activated. It is very hot.
  - Use gloves and safety glasses when handling an outer belt assy with a pretensioner that has been activated.
  - Always wash your hands with water after completing operation.
  - Do not apply water to an outer belt assy that has an activated pretensioner.
- (1) Remove the wheel and SST.

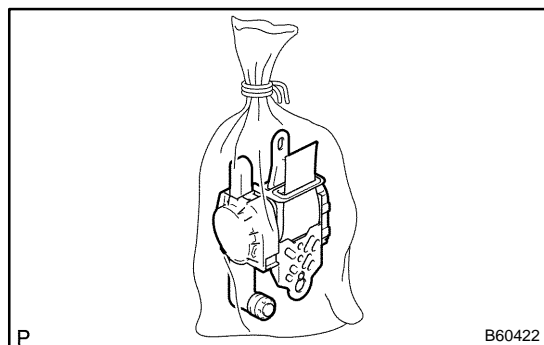

- (2) Place the outer belt in a plastic bag, tie the end tightly and dispose of it in the same way as other general parts.