

OVERHAUL

HINT:

- Installation is in the reverse order of removal.
 - COMPONENTS for instrument panel safety pad: See page 71-1.
 - COMPONENTS for blower assy: See page 55-29.
1. REMOVE INSTRUMENT PANEL SUB-ASSY W/PASSENGER AIRBAG ASSY (SEE PAGE 71-7)
 2. REMOVE INSTRUMENT PANEL SUB-ASSY LOWER (SEE PAGE 71-13)
 3. REMOVE TRANSMISSION CONTROL ECU ASSY
 4. REMOVE ECM (SEE PAGE 10-24)
 5. REMOVE NETWORK GATEWAY ECU (SEE PAGE 67-26)
 6. REMOVE HEATER TO REGISTER DUCT NO.1 (SEE PAGE 55-17)

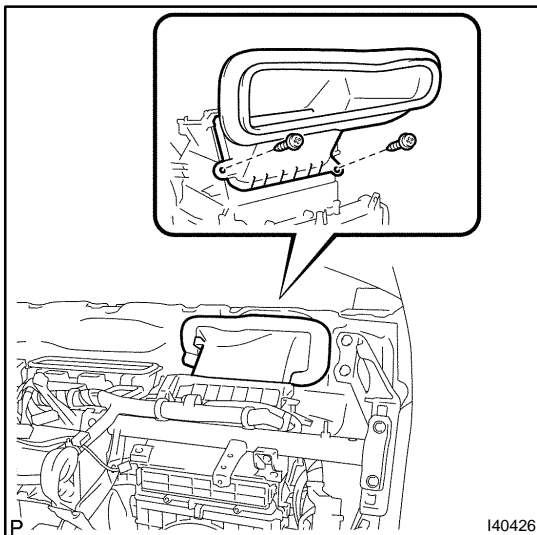

7. REMOVE AIR DUCT SUB-ASSY

- (a) Remove the 2 screws and then the air duct sub-assy.

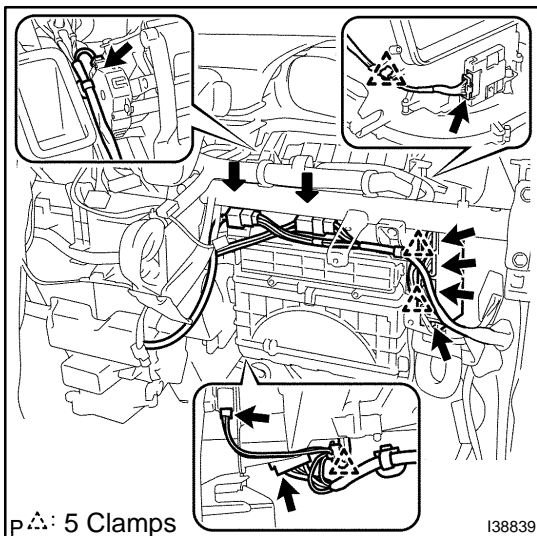

8. REMOVE BLOWER ASSY

- (a) Disconnect the 10 connectors and remove the 5 clamps.
- (b) Disconnect the wire harness.

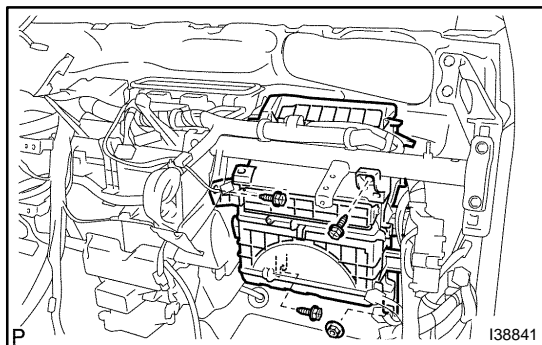

- (c) Remove the 3 screws the nut and then the blower assy.

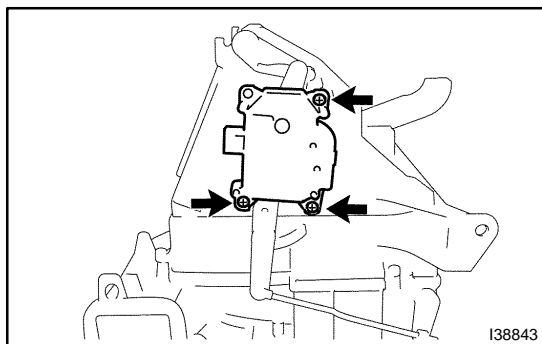

9. REMOVE AIR INLET SERVOMOTER

- (a) Remove the 3 screws and then the air inlet servomotor.

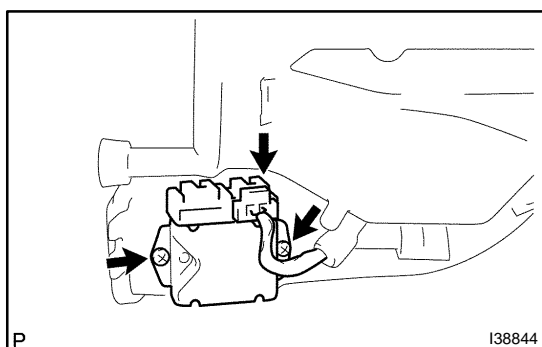

10. REMOVE BLOWER MOTOR CONTROL

- (a) Disconnect the connector and remove the 2 screws.
 (b) Remove the blower motor control.

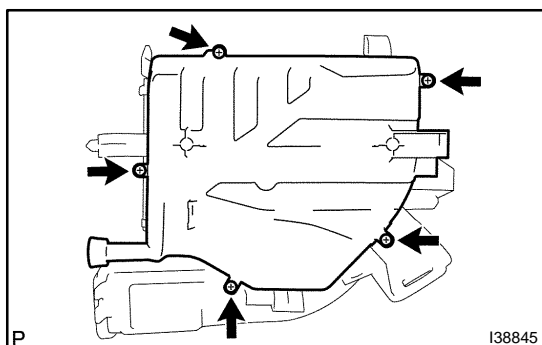

11. REMOVE COOLER WIRING HARNESS SUB-ASSY NO.2

- (a) Remove the 5 screws and then the blower motor cover.

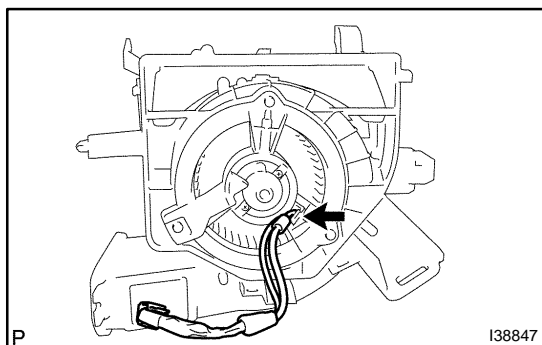

- (b) Remove the cooler wiring harness sub-assy No.2 from the blower w/fan motor sub-assy.

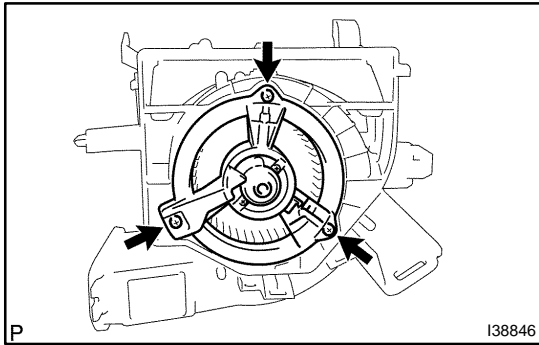
**12. REMOVE BLOWER W/FAN MOTOR SUB-ASSY**

- (a) Remove the 3 screws and then the blower w/fan motor sub-assy.

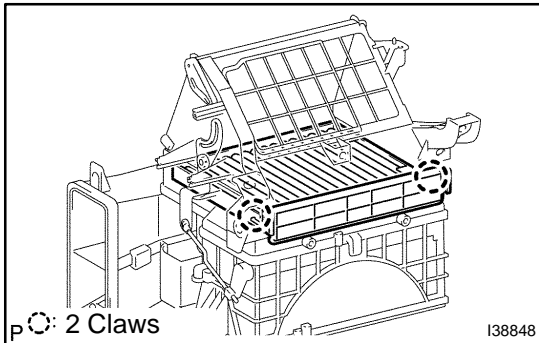
**13. REMOVE CLEAN AIR FILTER**

- (a) Disengage the 2 claws and then remove the air filter cover plate with the clean air filter.
- (b) Remove the clean air filter from the air filter cover plate.

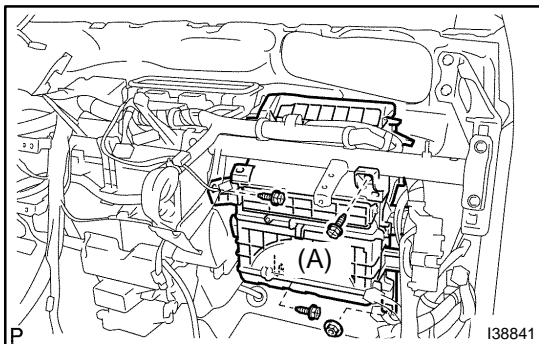
**14. INSTALL BLOWER ASSY**

- (a) Install the blower assy with the 3 screws

HINT:

Use repair screw (parts No.90159-70003) if the screw (A) removed before cannot be tightened.

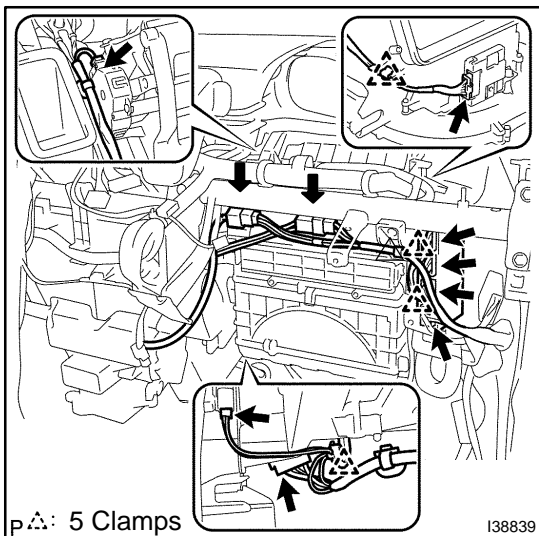

- (b) Install the wire harness with the 10 connectors and 5 clamps.
- (c) Install the transponder key computer assy connector.

15. INSTALL INSTRUMENT PANEL SUB-ASSY LOWER (SEE PAGE 71-13)

HINT:

Refer to the installation procedures for the instrument panel sub-assy lower.

2004 Prius – Preliminary Release (RM1075U)

**16. INSTALL INSTRUMENT PANEL SUB-ASSY W/PASSENGER AIRBAG ASSY
(SEE PAGE 71-7)**

HINT:

Refer to the installation procedures for the instrument panel with the passenger airbag assy.