

DTC	P0336/137	CRANKSHAFT POSITION SENSOR "A" CIRCUIT RANGE/PERFORMANCE
------------	------------------	---

DTC	P0340/532	CAMSHAFT POSITION SENSOR "A" CIRCUIT
------------	------------------	---

CIRCUIT DESCRIPTION

If there is any malfunction in the communication values or pulse inputs, the HV control ECU detects it by comparing the following three speeds: the engine speed transmitted by the ECM via CAN (Controller Area Network) communication, the engine speed obtained through pulse inputs, and the engine speed calculated from the MG1 and MG2 speeds.

DTC No.	INF Code	DTC Detection Condition	Trouble Area
P0336	137	Engine speed sensor deviation malfunction (CAN communication)	<ul style="list-style-type: none"> • Wire harness or connector • Crankshaft position sensor • Camshaft position sensor • HV control ECU
P0340	532	Engine speed sensor deviation malfunction (pulse signal)	<ul style="list-style-type: none"> • Wire harness or connector • Crankshaft position sensor • Camshaft position sensor • HV control ECU

WIRING DIAGRAM

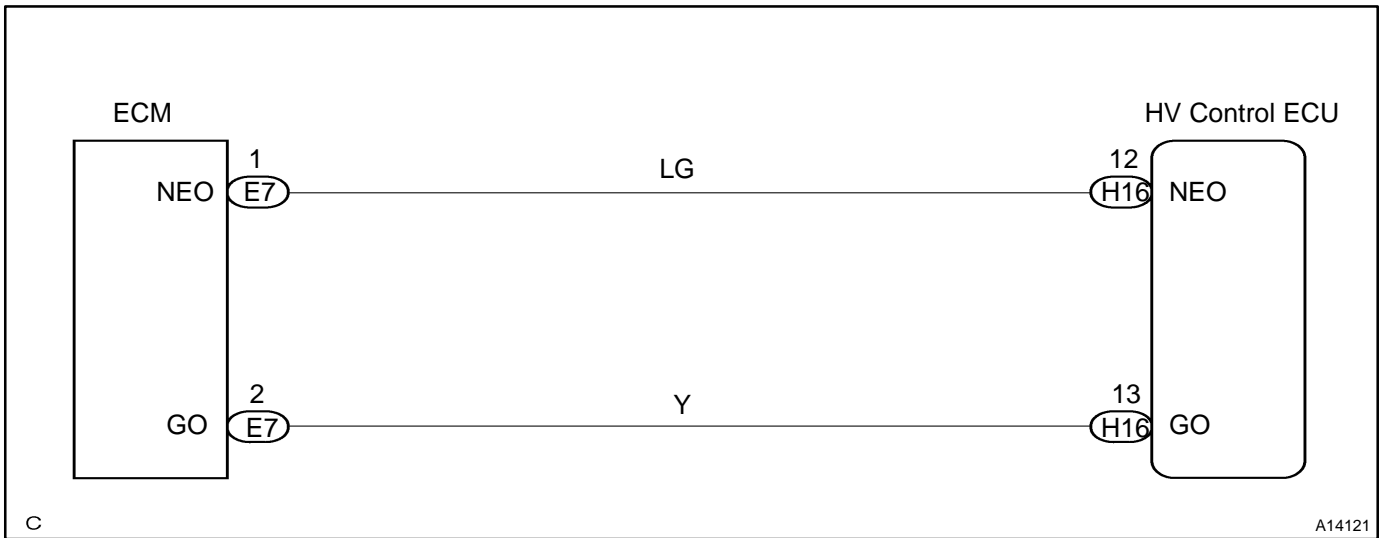

INSPECTION PROCEDURE

1 READ OUTPUT DTC(ENGINE)

- (a) Connect the hand-held tester to the DLC3.
- (b) Turn the power switch ON (IG).
- (c) Turn the hand-held tester ON.
- (d) On the hand-held tester, enter the following menus: DIAGNOSIS / ENHANCED OBD II / ENGINE AND ECT / DTC INFO / TROUBLE CODES.
- (e) Read DTCs.

Result: DTCs are output

YES → **GO TO RELEVANT DTC CHART**
(See page 05-55)

NO

2 CHECK HARNESS AND CONNECTOR(HYBRID VEHICLE CONTROL ECU – ECM)

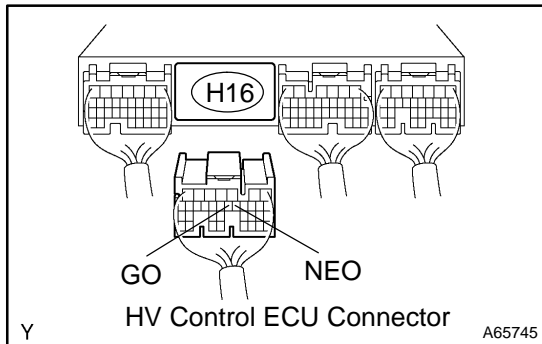

- (a) Disconnect the H16 HV control ECU connector.
- (b) Disconnect the E7 ECM connector.
- (c) Check the resistance between the wire harness side connectors.

Standard (Check for open):

Tester Connection	Specified Condition
NEO (H16-12) – NEO (E7-1)	Below 1 Ω
GO (H16-13) – GO (E7-2)	Below 1 Ω

Standard (Check for short):

Tester Connection	Specified Condition
NEO (H16-12) or NEO (E7-1) – Body ground	10 kΩ or higher
GO (H16-13) or GO (E7-2) – Body ground	10 kΩ or higher

- (d) Reconnect the ECM connector.
- (e) Reconnect the HV control ECU connector.

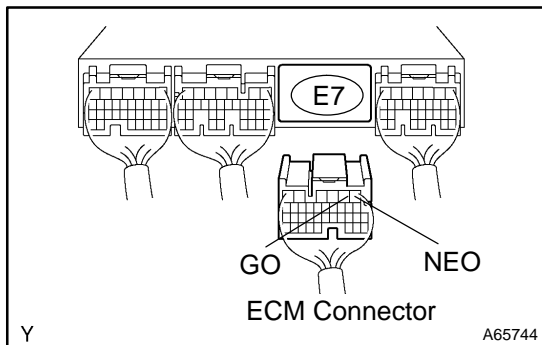

NG → **REPAIR OR REPLACE HARNESS OR CONNECTOR**

OK

3 INSPECT CRANKSHAFT POSITION SENSOR (See Page 18-6)

NG → **REPLACE CRANKSHAFT POSITION SENSOR**
(See page 18-10)

OK

4 INSPECT CAMSHAFT POSITION SENSOR (See page 18-6)

NG

REPLACE CAMSHAFT POSITION SENSOR
(See page 18-8)

OK

REPLACE HYBRID VEHICLE CONTROL ECU (See page 21-124)