

DTC	C1235/35	FOREIGN MATTER IS ATTACHED ON TIP OF RIGHT FRONT SENSOR
DTC	C1236/36	FOREIGN MATTER IS ATTACHED ON TIP OF LEFT FRONT SENSOR
DTC	C1238/38	FOREIGN MATTER IS ATTACHED ON TIP OF RIGHT REAR SENSOR
DTC	C1239/39	FOREIGN MATTER IS ATTACHED ON TIP OF LEFT REAR SENSOR

CIRCUIT DESCRIPTION

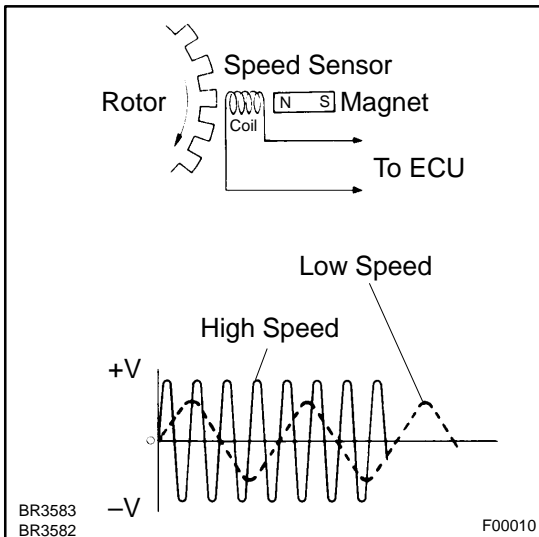

The speed sensor detects wheel speed and sends the appropriate signals to the ECU. These signals are used to control the ABS control system. The front and rear rotors have 48 serrations respectively.

When the rotors rotate, the magnetic field emitted by the permanent magnet in the speed sensor generates an AC voltage. Since the frequency of this AC voltage changes in direct proportion to the speed of the rotor, the frequency is used by the ECU to detect the speed of each wheel.

When foreign matter adheres to the speed sensor tip or sensor rotor, or the rotor teeth are chipped, these DTCs are output. An abnormal waveform input from the sensor determines these conditions.

These DTCs may be detected when a malfunction occurs in the connector terminals or wire harness of the speed sensor circuit.

DTC No.	Detailed Code	DTC Detecting Condition	Trouble Area
C1235/35	-	Pulse waveform of speed sensor signal is abnormal for at least 5 sec. when vehicle speed is 12 mph (20 km/h) or more.	<ul style="list-style-type: none"> • Right front speed sensor • Each speed sensor circuit • Sensor installation • Skid control ECU
C1236/36	303	Pulse waveform of speed sensor signal is abnormal for at least 5 sec. when vehicle speed is 12 mph (20 km/h) or more.	<ul style="list-style-type: none"> • Left front speed sensor • Each speed sensor circuit • Sensor installation • Skid control ECU
C1238/38	304	Pulse waveform of speed sensor signal is abnormal for at least 5 sec. when vehicle speed is 12 mph (20 km/h) or more.	<ul style="list-style-type: none"> • Right rear speed sensor • Each speed sensor circuit • Skid control ECU
C1239/39	305	Pulse waveform of speed sensor signal is abnormal for at least 5 sec. when vehicle speed is 12 mph (20 km/h) or more.	<ul style="list-style-type: none"> • Left rear speed sensor • Each speed sensor circuit • Skid control ECU

HINT:

- DTC C1235/35 is for the right front speed sensor.
- DTC C1236/36 is for the left front speed sensor.
- DTC C1238/38 is for the right rear speed sensor.
- DTC C1239/39 is for the left rear speed sensor.

WIRING DIAGRAM

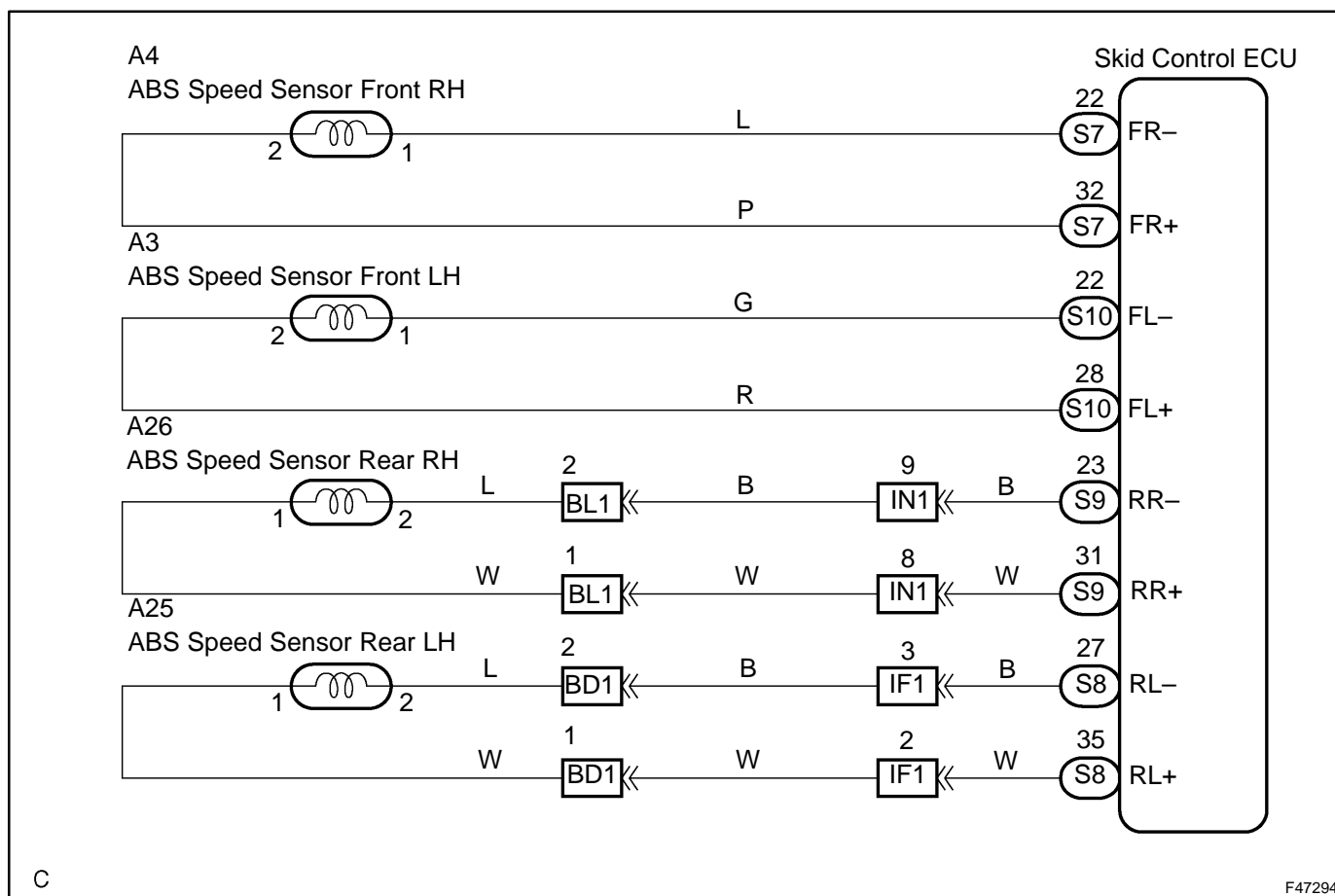

INSPECTION PROCEDURE

1 INSPECT SPEED SENSOR AND SENSOR ROTOR SERRATIONS

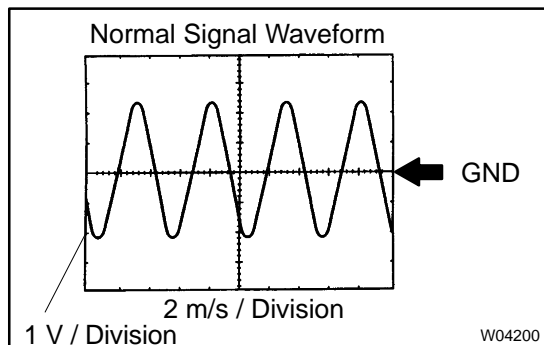

INSPECTION USING OSCILLOSCOPE

- Connect the oscilloscope to terminal FR+ – FR– or FL+ – FL– of the skid control ECU.
- Drive the vehicle at approximately 19 mph (30 km/h), and check the signal waveform.

OK:

A waveform as shown in a figure should be output.

- As the vehicle speed (wheel revolution speed) increases, a cycle of the waveform narrows and the fluctuation in the output voltage becomes greater.
- When noise is identified in the waveform on the oscilloscope, error signals are generated due to the speed sensor rotor's scratches, looseness or foreign matter attached to it.

NG → Go to step 4

OK

2 INSPECT SPEED SENSOR AND SENSOR ROTOR SERRATIONS

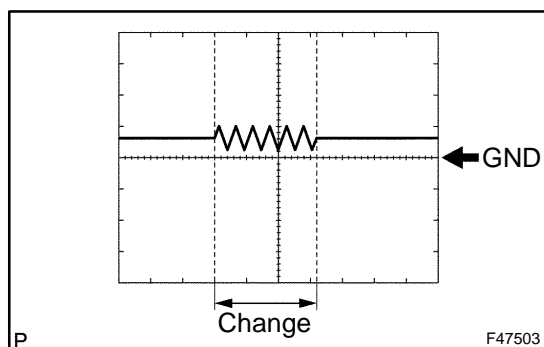

INSPECTION USING OSCILLOSCOPE

- Connect the oscilloscope to terminal FR+ – FR– or FL+ – FL– of the skid control ECU.
- Check if the oscilloscope has any change when the wire harness connector is subject to vibration while the vehicle is stopped and the ignition switch is on.
(If the connector is poorly connected, vibration of the wire harness connector may cause a temporary stop in current flow.)

OK:

There is no change in a waveform.

Result:

OK	No Change	A
NG	Change	B

B → REPAIR OR REPLACE HARNESS OR CONNECTOR

A

3	RECONFIRM DTC
----------	----------------------

- (a) Clear the DTCs (see page [05-975](#)).
- (b) Turn the power switch ON (READY).
- (c) Check the same DTCs are recorded (see page [05-975](#)).

Result:

DTC is not output	A
DTC is output	B

B

REPLACE SKID CONTROL ECU ASSY

A

PROCEED TO NEXT CIRCUIT INSPECTION SHOWN IN PROBLEM SYMPTOMS TABLE (SEE PAGE 05-966)

4	INSPECT SPEED SENSOR TIP
----------	---------------------------------

- (a) Remove the front axle hub and front speed sensor.
- (b) Check the sensor tip.

OK:**No scratches or foreign matter on the sensor tip.****NOTICE:**

**Check the speed sensor signal after the replacement
(see page [05-961](#)).**

NG

CLEAN OR REPLACE SPEED SENSOR

OK

5	INSPECT SPEED SENSOR ROTOR
----------	-----------------------------------

- (a) Remove the front axle hub and front speed sensor rotor.
- (b) Check the sensor rotor serrations.

OK:**No scratches, missing teeth or foreign matter on the rotors.****HINT:**

If there is foreign matter in the rotor, remove it and check the output waveform after reassembly.

NOTICE:**Check the speed sensor signal after the replacement (see page [05-961](#)).**

NG

CLEAN OR REPLACE SPEED SENSOR ROTOR
--

OK

REPLACE SPEED SENSOR
