

# ILLUMINATION CIRCUIT

## CIRCUIT DESCRIPTION

When the light control switch is turned to TAIL or HEAD position, the T-LP relay activates and power is supplied to the radio receiver assy and the multi-display panel illumination. The body ECU determines the surrounding illumination intensity according to the illumination intensity detected by the automatic light control sensor and activates the T-LP relay, allowing power to be supplied to the radio receiver assy and the multi-display panel illumination.

Illumination intensity adjustment for the radio receiver assy and multi-display panel illumination is performed with the rheostat switch.

HINT:

If a problem exists in the automatic light control sensor, DTC B1244 is output.

## WIRING DIAGRAM

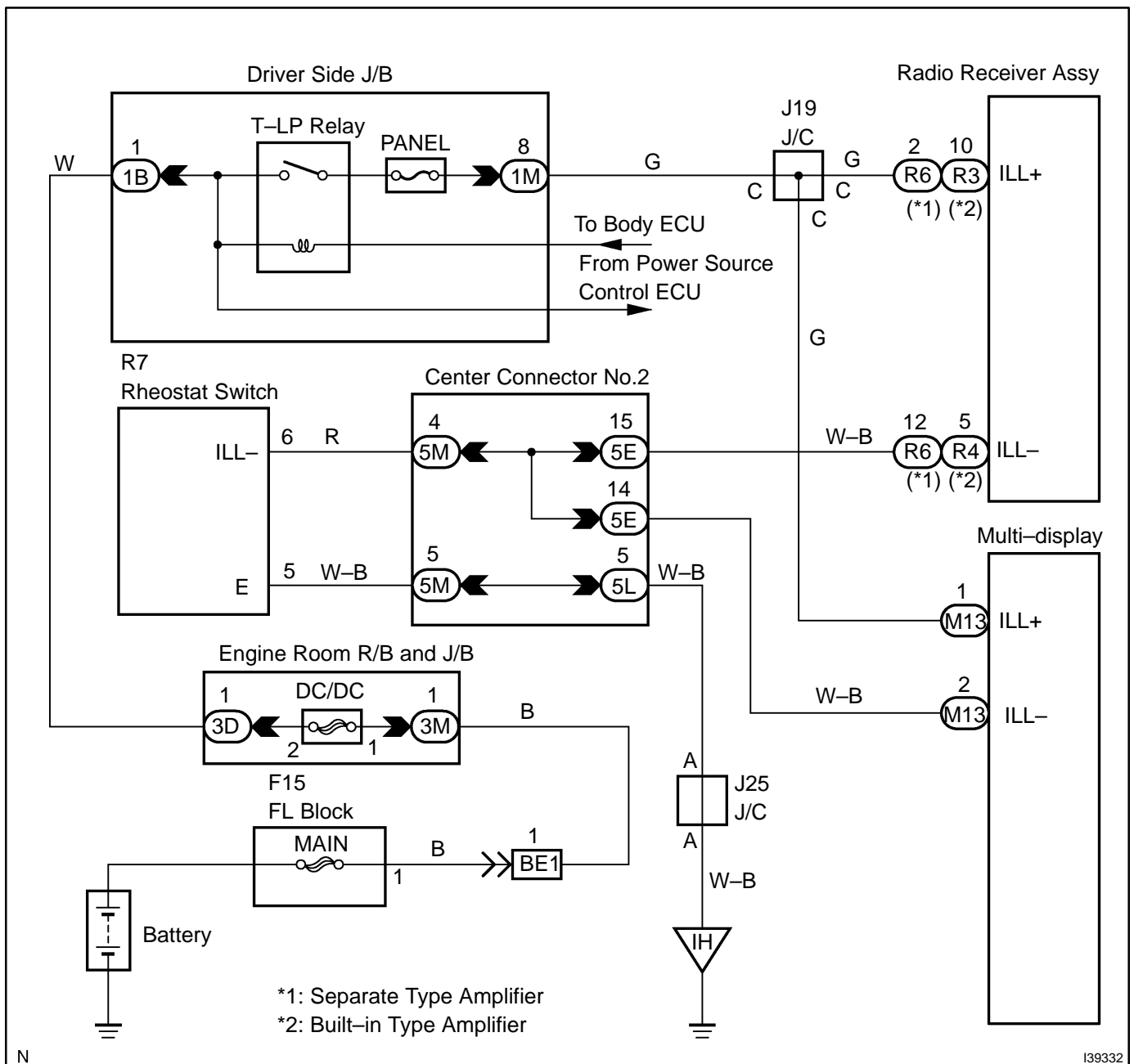

# INSPECTION PROCEDURE

## 1 CHECK CONDITION

(a) Check all components with illumination malfunctions.

Components with malfunction	Go to step
Radio receiver assy and/or multi-display	A
All illumination (Radio receiver assy, multi-display combination meter and hazard warning switch)	B

HINT:

If all the illuminations have malfunctions, check the rheostat switch.

**B** GO TO COMBINATION METER SYSTEM (SEE PAGE 05-1983)

**A**

## 2 CHECK HARNESS AND CONNECTOR (COMPONENTS WITH MALFUNCTION - BATTERY)

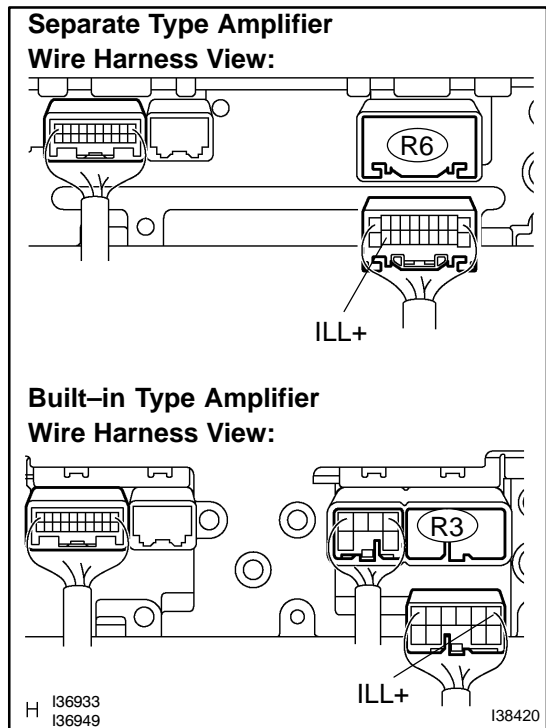

(a) RADIO RECEIVER ASSY

- (1) Disconnect the radio receiver assy R6 or R3 connector.
- (2) Measure the voltage according to the values in the table below.

**Standard:**

Tester connection	Condition	Specified condition
ILL+ (R6-2) - Body ground *1	Light control switch TAIL or HEAD	10 to 14 V
ILL+ (R3-10) - Body ground *2	Light control switch TAIL or HEAD	10 to 14 V

\*1: Separate Type Amplifier

\*2: Built-in Type Amplifier

**Multi-display Wire Harness View:**

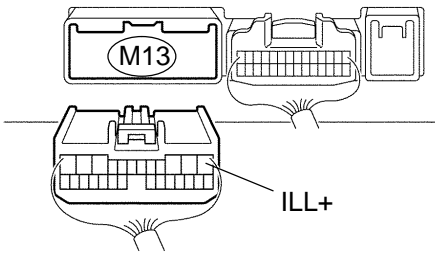

P I39881

- (b) MULTI-DISPLAY
- (1) Disconnect the multi-display M13 connector.
  - (2) Measure the voltage according to the values in the table below.

**Standard:**

Tester connection	Condition	Specified condition
ILL+ (M13-1) - Body ground	Light control switch TAIL or HEAD	10 to 14 V

**NG** → **REPAIR OR REPLACE HARNESS OR CONNECTOR**

**OK**

**3 CHECK HARNESS AND CONNECTOR (COMPONENTS WITH MALFUNCTION - RHEOSAT SWITCH)**

**Separate Type Amplifier Wire Harness View:**

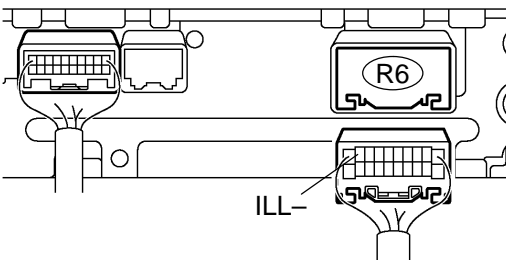

**Built-in Type Amplifier Wire Harness View:**

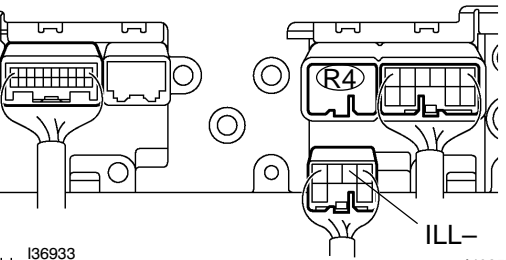

H I36933 I36950 I40257

- (a) RADIO RECEIVER ASSY
- (1) Disconnect the radio receiver assy R4 or R6 connector and rheostat switch R7 connector.
  - (2) Measure the resistance according to the values in the table below.

**Standard:**

Tester connection	Condition	Specified condition
ILL- (R6-12) - ILL- (R7-6) *1	Always	Below 1 Ω
ILL- (R4-5) - ILL- (R7-6) *2	Always	Below 1 Ω

\*1: Separate Type Amplifier

\*2: Built-in Type Amplifier

**Light Control Rheostat Wire Harness View:**

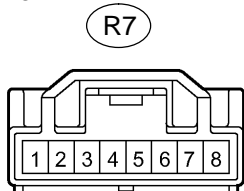

H I40235

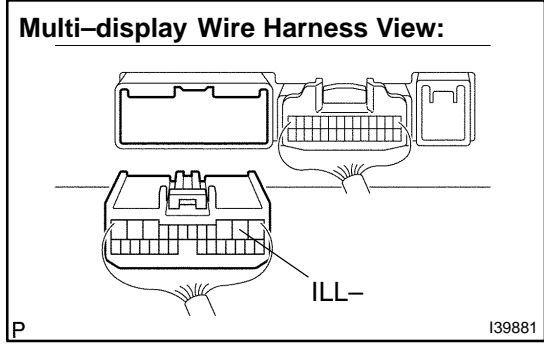

- (b) MULTI-DISPLAY
- (1) Disconnect the rheostat switch R7 connector.
  - (2) Measure the resistance according to the values in the table below.

**Standard:**

Tester connection	Condition	Specified condition
ILL- (M13-2) - ILL- (R7-6)	Always	Below 1 Ω

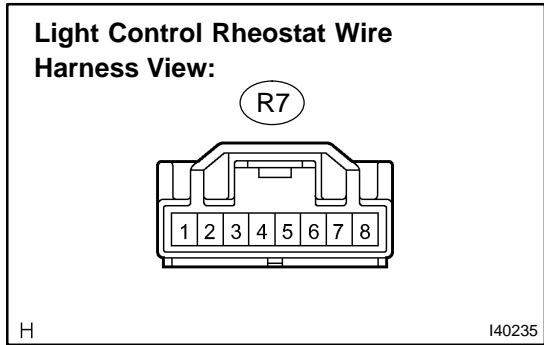

**NG** REPAIR OR REPLACE HARNESS OR CONNECTOR

**OK**

**4 CHECK HARNESS AND CONNECTOR**

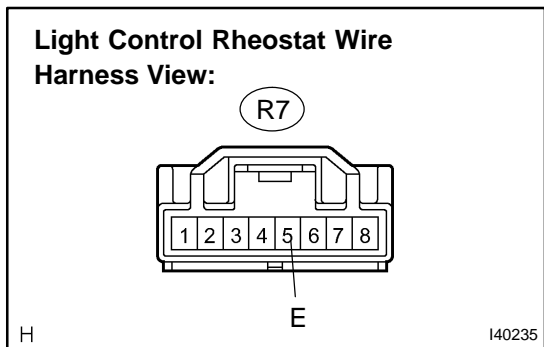

- (a) Measure the resistance according to the values in the table below.

**Standard:**

Tester connection	Condition	Specified condition
E (R7-5) - Body ground	Always	Below 1 Ω

**NG** REPAIR OR REPLACE HARNESS OR CONNECTOR

**OK**

**5 INSPECT LIGHT CONTROL RHEOSTAT**

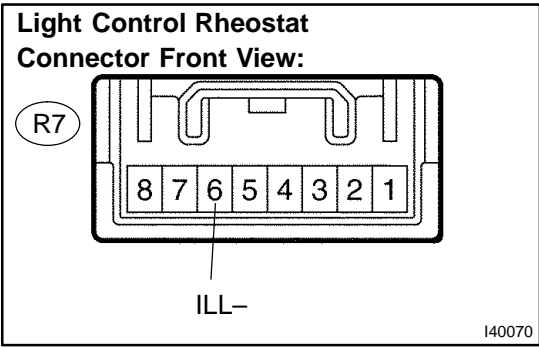

- (a) Reconnect the connectors.
- (b) Measure the voltage according to the values in the table below.

**Standard:**

Tester connection	Condition	Specified condition
ILL- (R7-6) - Body ground	Light control rheostat is turned volume up → volume down	Pulse generation (see waveform 1)

**HINT:**

Waveform 1: Inspection using oscilloscope.

**Standard:**

Item	Condition
Tool setting	2 V/DIV, 1 ms/DIV
Vehicle condition	Light control switch TAIL or HEAD

**HINT:**

Duty ratio changes as illumination becomes darker ("A" becomes longer).

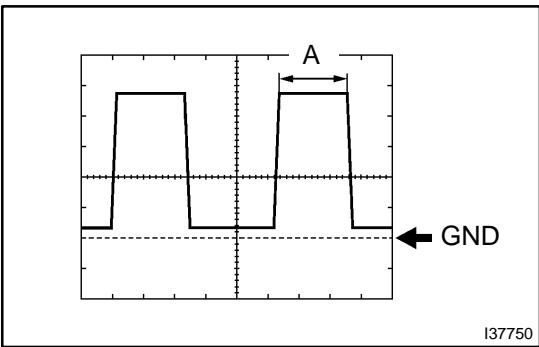

**NG** → **REPLACE LIGHT CONTROL RHEOSTAT**

**OK**

**PROCEED TO NEXT CIRCUIT INSPECTION SHOWN IN PROBLEM SYMPTOMS TABLE (SEE PAGE 05-1873)**