

DTC	B1835/58	SHORT IN CURTAIN SHIELD AIRBAG (P SEAT SIDE) SQUIB CIRCUIT
------------	-----------------	---

CIRCUIT DESCRIPTION

The curtain shield airbag (P seat side) squib circuit consists of the airbag ECU Assy and the curtain shield airbag Assy RH.

The circuit instructs the SRS to deploy when deployment conditions are met.

DTC B1835 is recorded when a short circuit is detected in the curtain shield airbag (P seat side) squib circuit.

DTC No.	DTC Detecting Condition	Trouble Area
B1835	<ul style="list-style-type: none"> • When the airbag ECU Assy receives a line short signal 5 times in the curtain shield airbag (P seat side) squib circuit during primary check. • Curtain shield airbag (P seat side) squib malfunction • Airbag ECU Assy malfunction 	<ul style="list-style-type: none"> • Floor wire No.2 • Curtain shield airbag Assy RH (Curtain shield airbag (P seat side) squib) • Airbag ECU Assy

WIRING DIAGRAM

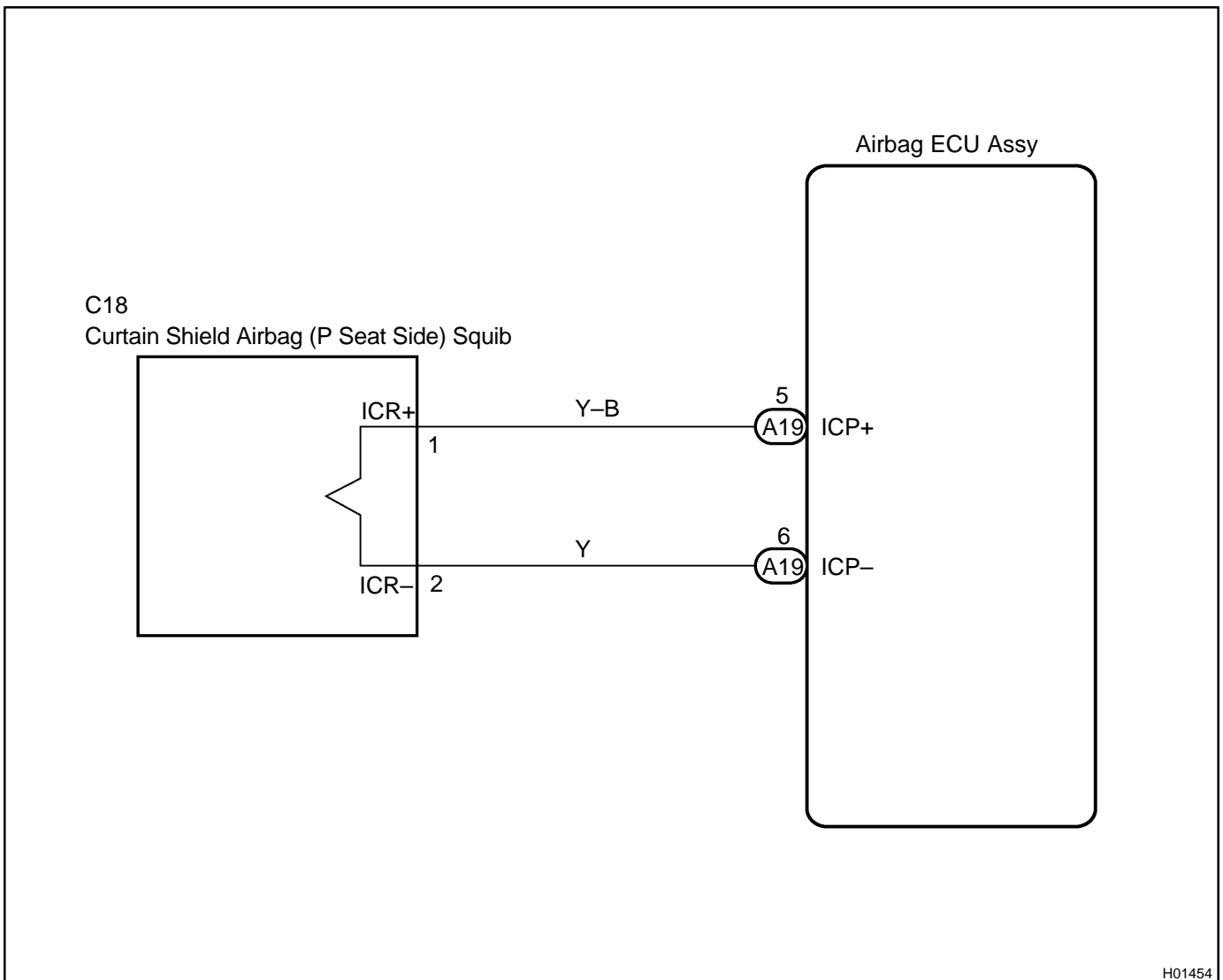

H01454

INSPECTION PROCEDURE

CAUTION:

Be sure to perform the following procedures before troubleshooting to avoid unexpected airbag deployment.

- (a) Turn the power switch off.
- (b) Disconnect the negative (-) terminal cable from the battery, and wait for at least 90 seconds.
- (c) Disconnect the connectors from the airbag ECU assy.
- (d) Disconnect the connectors from the horn button assy.
- (e) Disconnect the connectors from the front passenger airbag assy.
- (f) Disconnect the connector from the front seat airbag assy LH.
- (g) Disconnect the connector from the front seat airbag assy RH.
- (h) Disconnect the connector from the curtain shield airbag assy LH.
- (i) Disconnect the connector from the curtain shield airbag assy RH.
- (j) Disconnect the connector from the front seat outer belt assy LH.
- (k) Disconnect the connector from the front seat outer belt assy RH.

1 CHECK CONNECTOR

- (a) Check that the floor wire No.2 connector (on the curtain shield airbag assy RH side) is not damaged.
OK:
 The lock button is not disengaged, or the claw of the lock is not deformed or damaged.

NG REPAIR OR REPLACE FLOOR WIRE NO.2

OK

2 CHECK FLOOR WIRE NO.2(CURTAIN SHIELD AIRBAG (P SEAT SIDE) SQUIB CIRCUIT)

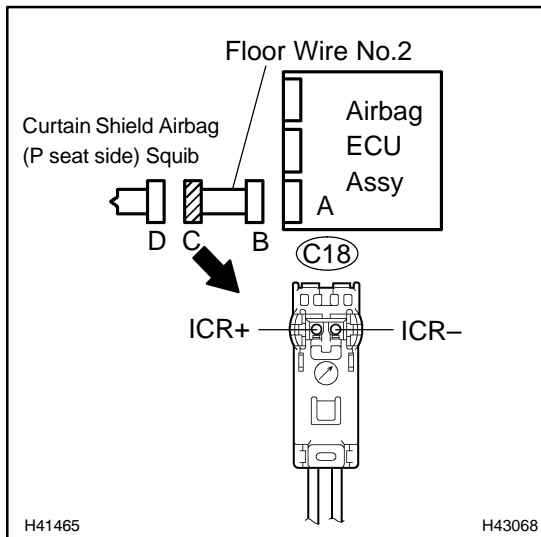

- (a) Release the activation prevention mechanism built into connector "B" (see page 05-1397).
- (b) Measure the resistance according to the value(s) in the table below.

Standard:

Tester connection	Condition	Specified condition
C18-1 (ICR+) - C18-2 (ICR-)	Always	1 MΩ or Higher

NG REPAIR OR REPLACE FLOOR WIRE NO.2

OK

3 CHECK AIR BAG ECU ASSY

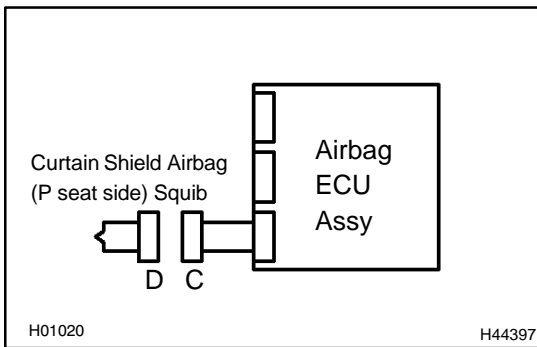

- (a) Connect the connectors to the airbag ECU Assy.
- (b) Connect the negative (–) terminal cable to the battery, and wait for at least 2 seconds.
- (c) Turn the power switch on (IG), and wait for at least 60 seconds.
- (d) Clear the DTCs stored in memory (see page 05-1402).
- (e) Turn the power switch off.
- (f) Turn the power switch on (IG), and wait for at least 60 seconds.
- (g) Check the DTCs (see page 05-1402).

OK:

DTC B1835 is not output.

HINT:

Codes other than code B1835 may be output at this time, but they are not related to this check.

NG

**REPLACE AIR BAG ECU ASSY
(SEE PAGE 60-54)**

OK

4	CHECK CURTAIN SHIELD AIR BAG ASSY RH(CURTAIN SHIELD AIRBAG (P SEAT SIDE) SQUIB)
----------	--

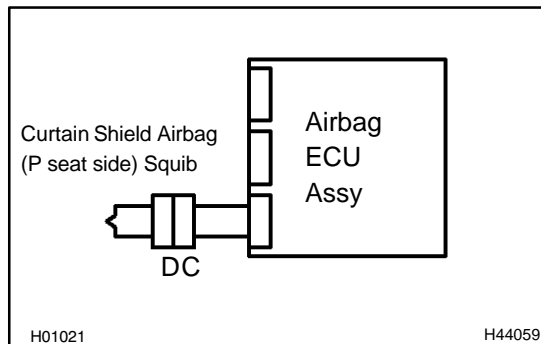

- (a) Turn the power switch off.
- (b) Disconnect the negative (-) terminal cable from the battery, and wait for at least 90 seconds.
- (c) Connect the connector to the curtain shield airbag assy RH.
- (d) Connect the negative (-) terminal cable to the battery, and wait for at least 2 seconds.
- (e) Turn the power switch on (IG), and wait for at least 60 seconds.
- (f) Clear the DTCs stored in memory (see page 05-1402).
- (g) Turn the power switch off.
- (h) Turn the power switch on (IG), and wait for at least 60 seconds.
- (i) Check the DTCs (see page 05-1402).

OK:

DTC B1835 is not output.

HINT:

Codes other than code B1835 may be output at this time, but they are not related to this check.

NG

**REPLACE CURTAIN SHIELD AIR BAG ASSY RH
(SEE PAGE 60-41)**

OK

USE SIMULATION METHOD TO CHECK (SEE PAGE 05-1397)

HINT:

- Perform the simulation method by selecting the check mode with the hand-held tester (see page 05-1405).
- After selecting the check mode, perform the simulation method by wiggling each connector of the airbag system or driving the vehicle on a city or rough road (see page 05-1405).