

DTC	P0A78/286	DRIVE MOTOR "A" INVERTER PERFORMANCE
------------	------------------	---

CIRCUIT DESCRIPTION

See the description of the inverter on page [05-562](#).

If the motor inverter has a circuit malfunction, internal short, or overheats, the inverter transmits that information to the MFIV terminal of the HV control ECU via the motor inverter fail signal line.

DTC No.	INF Code	DTC Detection Condition	Trouble Area
P0A78	286	Motor inverter fail (MFIV) signal detection (circuit malfunction)	<ul style="list-style-type: none"> • Wire harness or connector • w/ converter inverter assembly

MONITOR DESCRIPTION

If the motor inverter detects a circuit malfunction, it transmits a motor inverter fail signal to the HV control ECU. Upon receiving this signal, the HV control ECU illuminates the MIL and sets a DTC.

MONITOR STRATEGY

Related DTCs	P0A78 (INF 286): Motor inverter/MFIV detection circuit malfunction
Required sensor/components	Motor inverter
Frequency of operation	Continuous
Duration	TOYOTA's intellectual property
MIL operation	Immediately
Sequence of operation	None

TYPICAL ENABLING CONDITIONS

The monitor will run whenever the following DTCs are not present	TOYOTA's intellectual property
No other condition	–

TYPICAL MALFUNCTION THRESHOLDS

Motor inverter	Circuit malfunction
----------------	---------------------

COMPONENT OPERATING RANGE

Motor inverter	DTC P0A78 (INF 286) is not detected
----------------	-------------------------------------

WIRING DIAGRAM

Refer to DTC P0A78 (INF 282) on page [05-586](#).

INSPECTION PROCEDURE

CAUTION:

- Before inspecting the high-voltage system, take safety precautions to prevent electrical shocks, such as wearing insulated gloves and removing the service plug grip. After removing the service plug grip, put it in your pocket to prevent other technicians from reconnecting it while you are servicing the high-voltage system.
- After disconnecting the service plug grip, wait at least for 5 minutes before touching any of the high-voltage connectors or terminals.

HINT:

At least 5 minutes is required to discharge the high-voltage condenser inside the inverter.

1 READ OUTPUT DTC(HV ECU)

- (a) Connect the hand-held tester to the DLC3.
- (b) Turn the power switch ON (IG).
- (c) Turn the hand-held tester ON.
- (d) On the hand-held tester, enter the following menus: DIAGNOSIS / ENHANCED OBD II / HV ECU / DTC INFO / TROUBLE CODES.
- (e) Read DTCs.

Result: DTC listed in the table below is output

DTC No.	INF Code	Detection Item	See Page
P0A78	283 or 285	Drive Motor "A" Inverter performance	05-590

YES

GO TO THE PAGE NUMBER SHOWN IN THE TABLE ABOVE

NO

2 CHECK CONNECTION CONDITION OF INVERTER CONNECTOR(LOOSENESS AND POOR CONTACT)

CAUTION:

Wear insulated gloves before performing the following operation.

- (a) Turn the power switch OFF.
- (b) Remove the service plug grip (see page 21-116).

NOTICE:

Turning the power switch ON (READY) with the service plug grip removed could cause malfunction. Therefore, never turn the power switch ON (READY) in this state.

- (c) Remove the inverter cover (see page 21-23).
- (d) Check the connection condition of the I9 and I10 inverter connectors.

OK: Connectors have been connected securely and there is no poor connection.

- (e) Reinstall the inverter cover (see page 21-23).
- (f) Reinstall the service plug grip (see page 21-116).

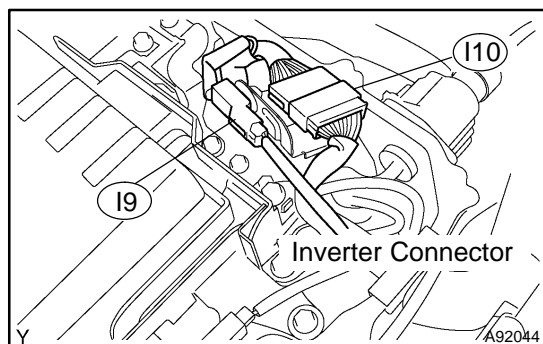

NG

CONNECT SECURELY

OK

3 READ OUTPUT DTC(HV ECU)

- (a) Connect the hand-held tester to the DLC3.
- (b) Turn the power switch ON (IG).

HINT:

DTCs for the interlock switch system are output when turning the power switch ON (IG) with both service plug grip and inverter cover removed.

- (c) Turn the hand-held tester ON.
- (d) On the hand-held tester, enter the following menus: DIAGNOSIS / ENHANCED OBD II / HV ECU / DTC INFO / TROUBLE CODES.
- (e) Read DTCs.

Result: DTCs P0A78 (INF 282, 286) and P0A7A (INF 324) (inverter circuit malfunction) are output

NO REPLACE W/CONVERTER INVERTER ASSY (See page 21-23)

YES

4 INSPECT W/CONVERTER INVERTER ASSY(IGCT VOLTAGE)

CAUTION:

Wear insulated gloves before performing the following operation.

- (a) Turn the power switch OFF.
- (b) Remove the service plug grip (see page 21-116).

NOTICE:

Turning the power switch ON (READY) with the service plug grip removed could cause malfunction. Therefore, never turn the power switch ON (READY) in this state.

- (c) Remove the inverter cover (see page 21-23).
- (d) Turn the power switch ON (IG).

HINT:

DTCs for the interlock switch system are output when turning the power switch ON (IG) with both service plug grip and inverter cover removed.

- (e) Measure the voltage between the terminals of the inverter connector.

Standard:

Tester Connection	Specified Condition
IGCT (I9-1) - GND1 (I9-2)	8 V or more

- (f) Turn the power switch OFF.
- (g) Reinstall the inverter cover (see page 21-23).
- (h) Reinstall the service plug grip (see page 21-116).

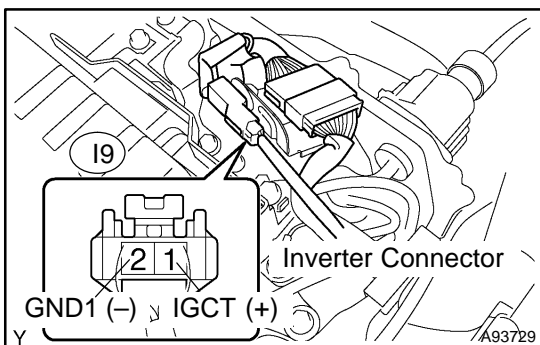

NG REPAIR OR REPLACE HARNESS OR CONNECTOR

OK

REPLACE W/CONVERTER INVERTER ASSY (See page 21-23)