

DIAGNOSIS SYSTEM

1. DESCRIPTION

(a) The hybrid vehicle control ECU controls vehicle's immobilizer system function. Immobilizer system data and the Diagnostic Trouble Codes (DTCs) can be read through the vehicle's Data Link Connector 3 (DLC3). In some cases, a malfunction may be occurring in the immobilizer system even though the security indicator lamp is off. When the system seems to be malfunctioning, use the hand-held tester to check for malfunctions and perform repairs.

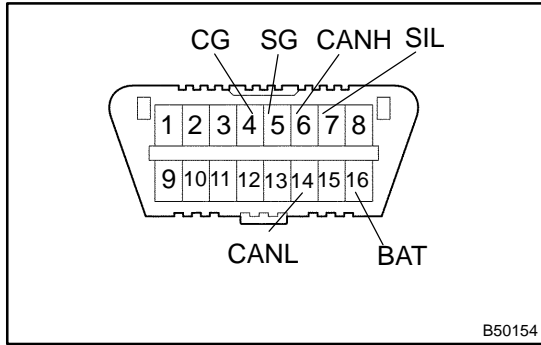

2. CHECK DLC3

The vehicle uses the ISO 15765-4 for communication protocol. The terminal arrangement of the DLC3 complies with SAE J1962 and matches the ISO 15765-4 format.

Symbol	Terminal No.	Name	Reference terminal	Result	Condition
SIL	7	Bus "+” line	5 – Signal ground	Pulse generation	During transmission
CG	4	Chassis ground	Body ground	Below 1 Ω	Constant
SG	5	Signal ground	Body ground	Below 1 Ω	Constant
BAT	16	Battery positive	Body ground	11 to 14 V	Constant
CANH	6	HIGH-level CAN bus line	CANL	54 to 69 Ω	Power switch's power mode OFF
CANH	6	HIGH-level CAN bus line	Battery positive	1 MΩ or higher	Power switch's power mode OFF
CANH	6	HIGH-level CAN bus line	CG	1 kΩ or higher	Power switch's power mode OFF
CANL	14	LOW-level CAN bus line	Battery positive	1 MΩ or higher	Power switch's power mode OFF
CANL	14	LOW-level CAN bus line	CG	1 kΩ or higher	Power switch's power mode OFF

If the result is not as specified, the DLC3 may have a malfunction. Repair or replace the harness and connector.

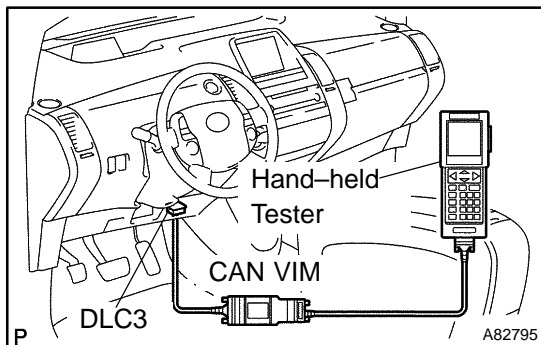

HINT:

Connect the cable of the hand-held tester (with CAN VIM) to the DLC3, change the power switch's power mode to ON (IG) and attempt to use the hand-held tester. If the screen displays UNABLE TO CONNECT TO VEHICLE, a problem exists in the vehicle side or tester side.

- If communication is normal when the tester is connected to another VIM, inspect the DLC3 of the original vehicle.
- If communication is still impossible when the tester is connected to another vehicle, the problem is probably in the tester itself. Consult the Service Department listed in the tester's instruction manual.

3. CHECK BATTERY VOLTAGE**Standard: 11 to 14 V**

If the voltage is below 11 V, replace the battery before proceeding.