

<b>DTC</b>	<b>B2797</b>	<b>COMMUNICATION MALFUNCTION NO.1</b>
------------	--------------	---------------------------------------

### CIRCUIT DESCRIPTION

This DTC is output when a communication error occurs between the transponder key amplifier and transponder key ECU. A possible reason for the communication error is that noise is occurring on the communication line. Following the inspection procedure below.

DTC No.	DTC Detection Condition	Trouble Area
B2797	Key has noise occurring on communication line	<ul style="list-style-type: none"> <li>• Smart key (Door control transmitter)</li> <li>• Wire harness</li> <li>• Key slot</li> <li>• Transponder key ECU Assy</li> </ul>

### WIRING DIAGRAM

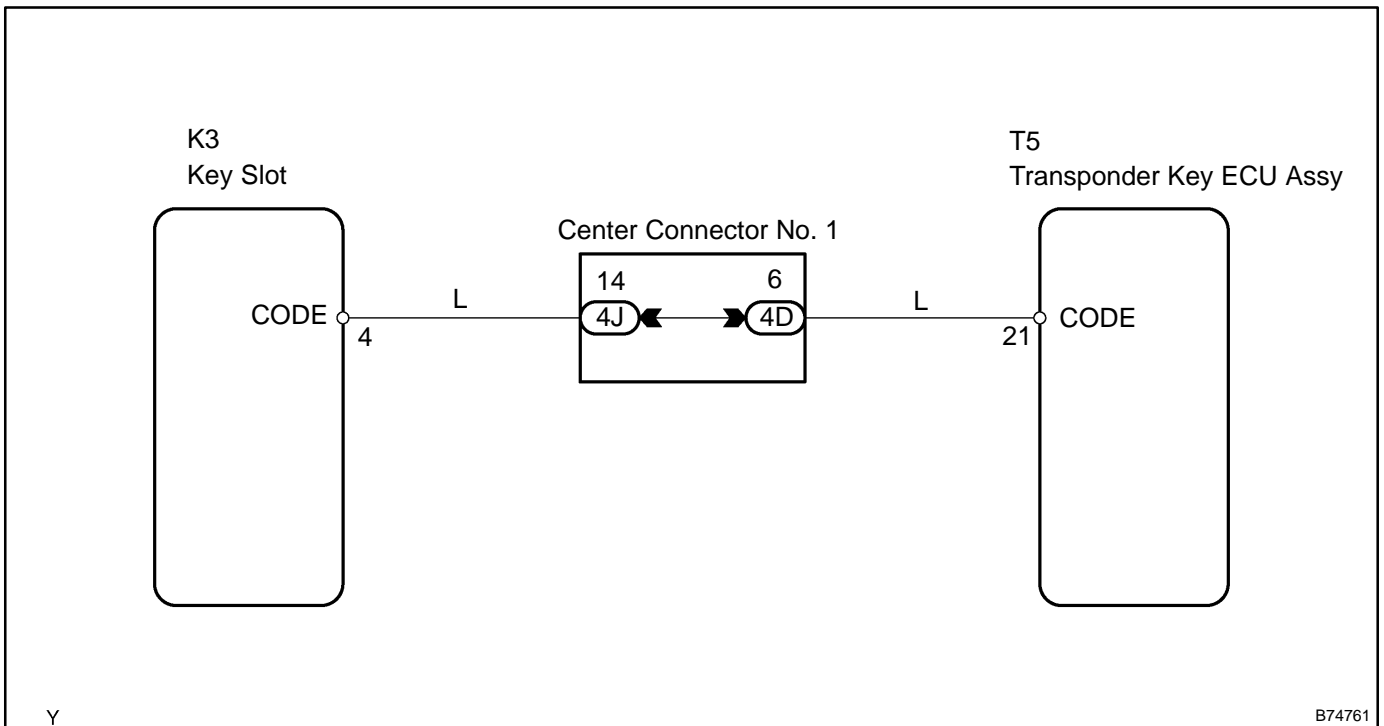

## INSPECTION PROCEDURE

### 1 CHECK TRANSPONDER KEY ECU ASSY

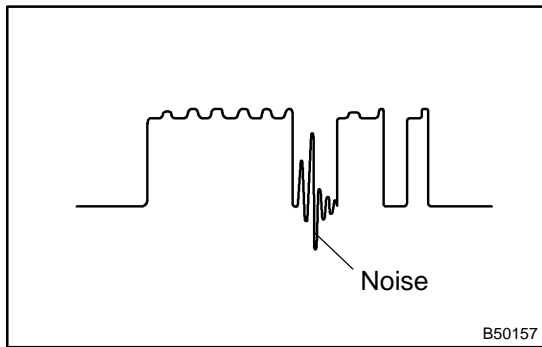

- (a) Using an oscilloscope or the hand-held tester, check that the waveform between the terminals of the K3 key slot and T5 ECU connector. The waveform should be similar to the illustration on the left.

**Standard:**

Tester Connection	Specified Condition
T5-21 (CODE) – K3-4 (CODE)	No noise is present

Tool Setting	2.5 V/DIV., 20 ms/DIV.
Condition	Power switch's power mode OFF <input type="checkbox"/> ON (IG)

**NG** FIND CAUSE OF NOISE AND REMOVE IT

**OK**

### 2 CHECK WIRE HARNESS (TRANSPONDER KEY ECU ASSY – KEY SLOT)

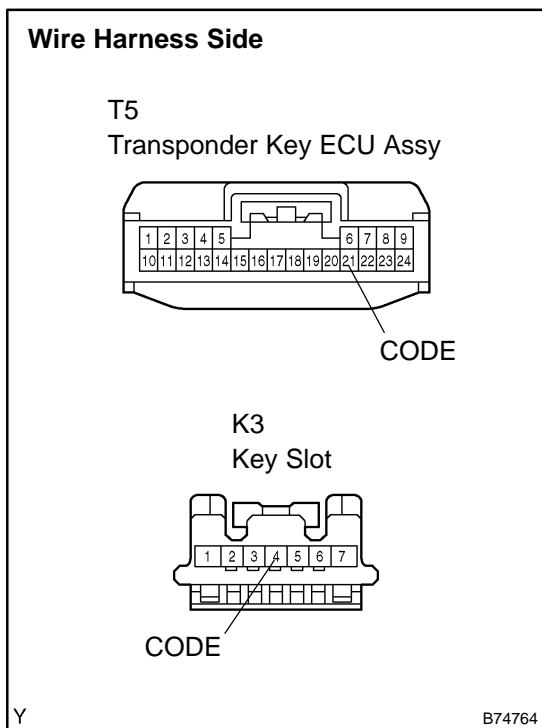

- (a) Disconnect the T5 ECU connector.  
 (b) Disconnect the K3 key slot connector.  
 (c) Measure the resistance of the wire harness side connectors.

**Standard:**

Tester Connection	Specified Condition
T5-21 (CODE) – K3-4 (CODE)	Below 1 Ω

**NG** REPAIR OR REPLACE WIRE HARNESS AND CONNECTOR

**OK**

**3 CHECK OPERATION OF KEY SLOT**

- (a) After replacing the key slot with normally functioning key slot, check that the power switch's power mode can be changed to ON (ACC and IG) and the hybrid control system can be started.

**OK:**

**Power switch's power mode can be changed to ON (ACC and IG) and hybrid control system can be started.**

**NG**

**REPLACE TRANSPONDER KEY ECU ASSY**

**OK**

**END (REPLACE KEY SLOT)**