

DTC	B1200	BODY ECU COMMUNICATION STOP
------------	--------------	------------------------------------

CIRCUIT DESCRIPTION

This DTC is detected when communication between the multiplex network body ECU and gateway ECU stops for more than 10 seconds.

DTC No.	DTC Detection Condition	Trouble Area
B1200	Body ECU communication stops	<ul style="list-style-type: none"> • Instrument panel J/B assy (Body ECU) • Wire harness

WIRING DIAGRAM

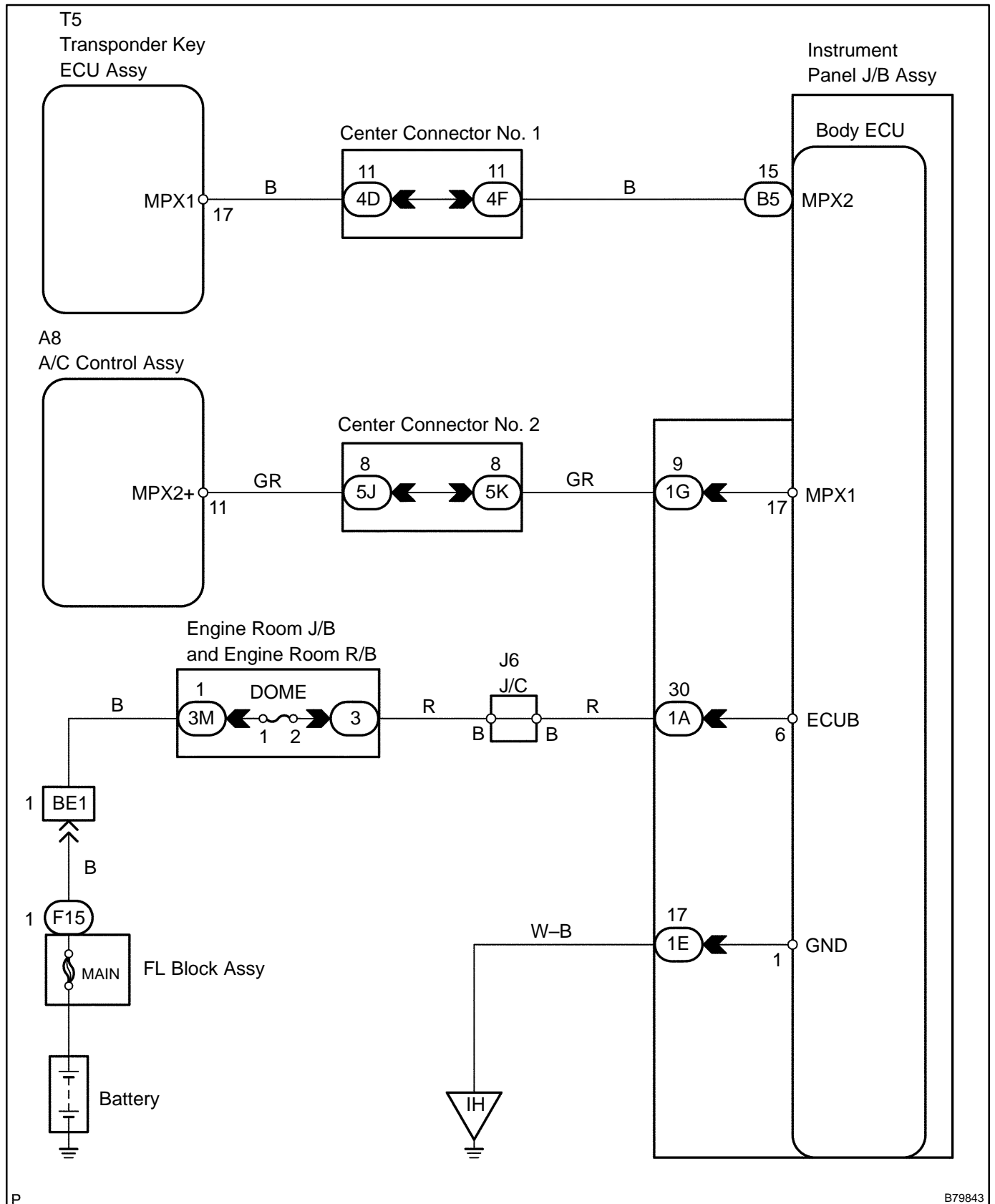

INSPECTION PROCEDURE

1 INSPECT FUSE (DOME)

- (a) Remove the DOME fuse from engine room J/B and engine room R/B.
- (b) Measure the resistance.

Standard: Below 1 Ω

NG → REPLACE FUSE

OK

2 CHECK WIRE HARNESS (INSTRUMENT PANEL J/B ASSY - BODY GROUND)

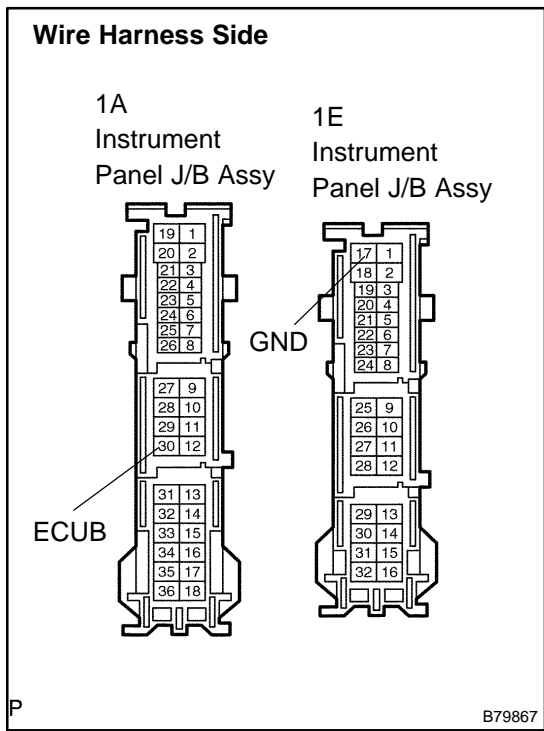

- (a) Disconnect the 1A and 1E J/B connectors.
- (b) Measure the voltage and resistance of the wire harness side connectors.

Standard:

Tester Connection	Specified Condition
1A-30 (ECUB) - Body ground	10 to 14 V
1E-17 (GND) - Body ground	Below 1 Ω

NG → REPAIR OR REPLACE HARNESS AND CONNECTOR

OK

3 CHECK RESISTANCE OF COMMUNICATION LINE

Wire Harness Side

1G
Instrument Panel J/B

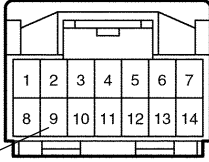

MPX1

T5
Transponder Key ECU Assy

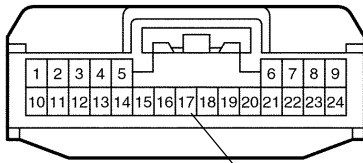

MPX1

A8
A/C Control Assy

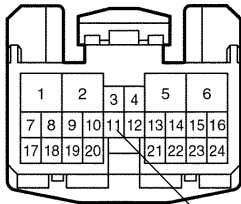

MPX2+

B5
Body ECU

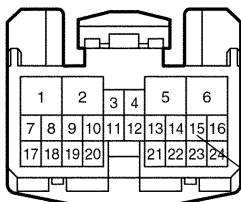

MPX2

P

B79845

A

- (a) Disconnect the 1G J/B connector.
- (b) Disconnect the T5, A8 and B5 ECU connectors.
- (c) Measure the resistance between the wire harness side connectors.

Standard:

Tester Connection	Specified Condition
T5-17 (MPX1) – B5-15 (MPX2)	Below 1 Ω
A8-11 (MPX2+) – 1G-9 (MPX1)	Below 1 Ω

Result:

Result	Proceed To
Both are OK	A
One is OK	B
Both are NG	C

B → REPLACE INSTRUMENT PANEL J/B ASSY AND REPAIR OR REPLACE HARNESS AND CONNECTOR

C → REPAIR OR REPLACE HARNESS AND CONNECTOR

REPLACE INSTRUMENT PANEL J/B ASSY (MULTIPLEX NETWORK BODY ECU)