

DTC	B1241	BODY ECU SWITCH CIRCUIT DIAGNOSIS
------------	--------------	--

CIRCUIT DESCRIPTION

DTC B1241 notifies how the door control switches on the master switch assembly and passenger's door work.

If this DTC is not output when one of the switches is operated, switch contact is faulty. If this DTC is output when neither switch is operated, one of the switches is in the lock/unlock position (ON) or stuck. When a malfunction is detected in these switches, inspect each switch. Then, replace the malfunctioning switch if necessary. If no malfunction is detected in these switches, check the wire harness and body ECU.

DTC No.	DTC Detecting Condition	Trouble Area
B1241	<ul style="list-style-type: none"> • Door control switch on master switch assembly is in lock/unlock position (ON) or stuck • Door control switch on passenger's door is in lock/unlock position (ON) or stuck 	<ul style="list-style-type: none"> • Power window regulator master switch assy • Door control switch assy • Instrument panel J/B assy (Multiplex network body ECU) • Wire harness

WIRING DIAGRAM

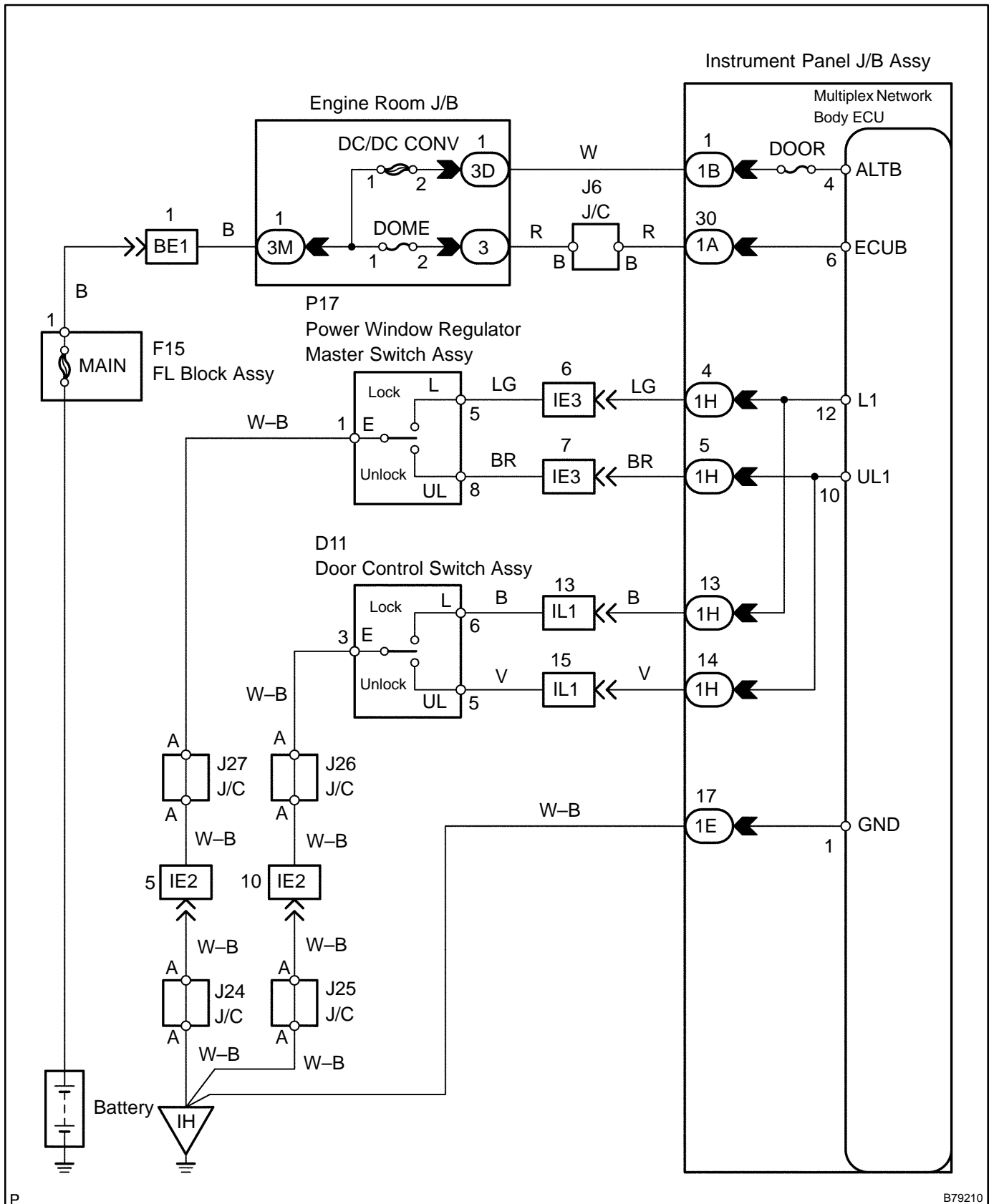

P

B79210

INSPECTION PROCEDURE

1 INSPECT FUSE (DOOR)

- (a) Remove the DOOR fuse from the instrument panel J/B.
 (b) Measure the resistance.

Standard: Below 1 Ω

NG → REPLACE FUSE

OK

2 READ VALUE OF HAND-HELD TESTER (DOOR CONTROL SWITCH)

- (a) Check the DATA LIST for proper functioning of the door control switch.

Multiplex network body ECU:

Item	Measurement Item/Display (Range)	Normal Condition	Diagnostic Note
D/L SW-LOCK	Door control switch lock signal /ON or OFF	ON: Door control switch is in the LOCK position OFF: Door control switch is not in the LOCK position	–
D/L SW-UNLOCK	Door control switch unlock signal /ON or OFF	ON: Door control switch is in the UNLOCK position OFF: Door control switch is not in the UNLOCK position	–

OK: "ON" (Door is locked/unlocked) appears on the screen.

NG → Go to step 3

OK

Go to step 5

3 INSPECT POWER WINDOW REGULATOR MASTER SWITCH ASSY (DOOR CONTROL SWITCH)

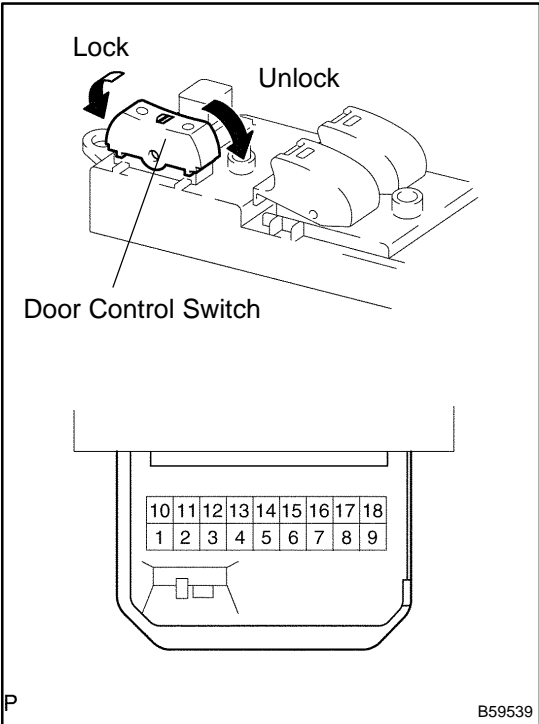

(a) Measure the resistance of the door control switch.

Standard:

Tester Connection	Door Lock Condition	Specified Condition
1 - 5	Lock	Below 1 Ω
1 - 5 1 - 8	OFF	10 kΩ or higher
1 - 8	Unlock	Below 1 Ω

NG → **REPLACE POWER WINDOW REGULATOR MASTER SWITCH ASSY**

OK

4 CHECK WIRE HARNESS (POWER WINDOW REGULATOR MASTER SWITCH ASSY (DOOR CONTROL SWITCH) – INSTRUMENT PANEL J/B ASSY AND BODY GROUND)

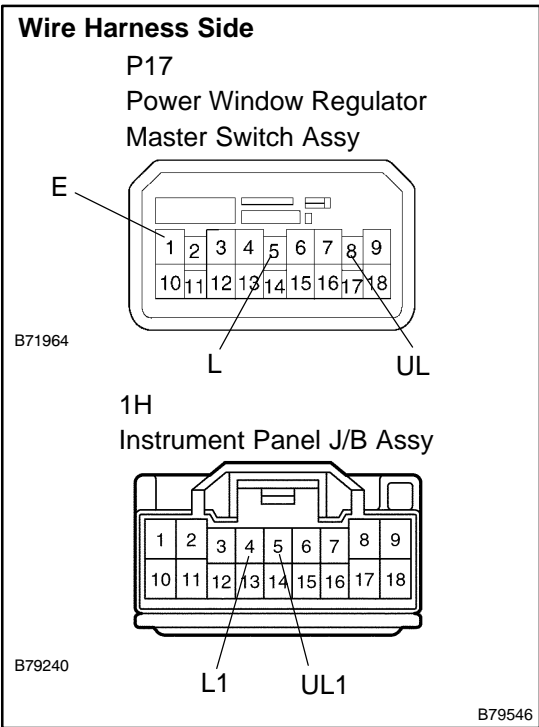

- (a) Disconnect the P17 switch and 1H J/B connectors.
- (b) Measure the resistance of the wire harness side connectors.

Standard:

Tester Connection	Specified Condition
P17-5 (L) – 1H-4 (L1)	Below 1 Ω
P17-8 (UL) – 1H-5 (UL1)	Below 1 Ω
P17-1 (E) – Body ground	Below 1 Ω

NG → **REPAIR OR REPLACE HARNESS AND CONNECTOR**

OK

5 CHECK DOOR CONTROL SWITCH ASSY

- (a) Press the lock switch on the passenger’s side door control switch and check that all the doors lock. Press the unlock switch on the passenger’s side door control switch and check that all the doors unlock.

OK: All doors lock/unlock when lock/unlock switches are pressed.

NG → **Go to step 6**

OK

Go to step 8

6 INSPECT DOOR CONTROL SWITCH ASSY

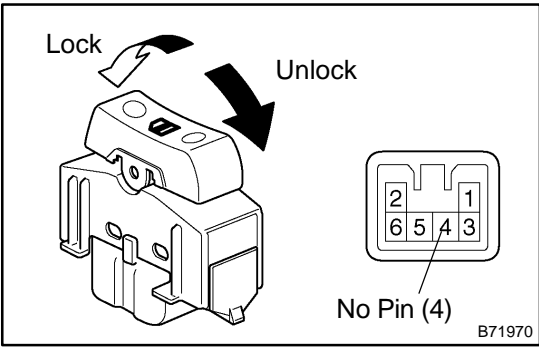

(a) Measure the resistance of the switch.

Standard:

Tester Connection	Door Lock Condition	Specified Condition
3-6	Lock	Below 1 Ω
3-5	OFF	10 kΩ or higher
3-6		
3-5	Unlock	Below 1 Ω

NG → **REPLACE DOOR CONTROL SWITCH ASSY**

OK

7 CHECK WIRE HARNESS (DOOR CONTROL SWITCH ASSY - INSTRUMENT PANEL J/B ASSY AND BODY GROUND)

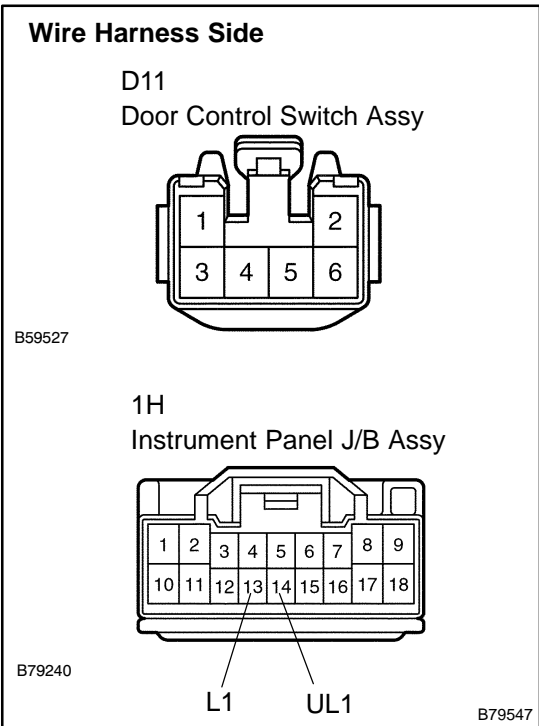

(a) Disconnect the D11 switch and 1H J/B connectors.
 (b) Measure the resistance of the wire harness side connectors.

Standard:

Tester Connection	Specified Condition
D11-6 - 1H-13 (L1)	Below 1 Ω
D11-5 - 1H-14 (UL1)	Below 1 Ω
D11-3 - Body ground	Below 1 Ω

NG → **REPAIR OR REPLACE HARNESS AND CONNECTOR**

OK

8 CHECK WIRE HARNESS (INTRUMENT PANEL J/B ASSY - BODY GROUND)

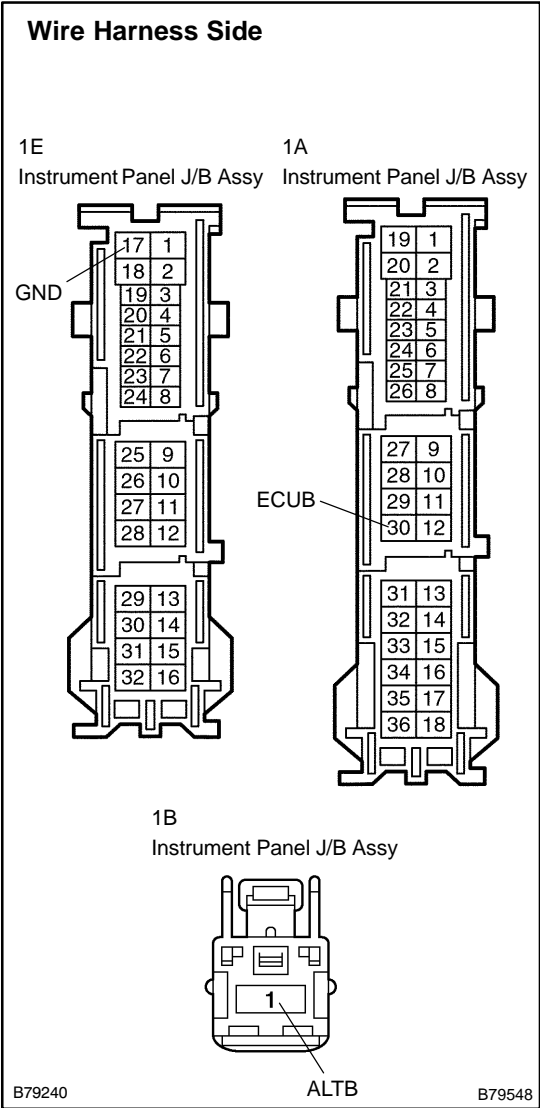

- (a) Disconnect the 1A, 1B and 1E J/B connectors.
- (b) Measure the resistance and voltage of the wire harness side connectors.

Standard:

Tester Connection	Specified Condition
1A-30 (ECUB) - Body ground	10 to 14 V
1B-1 (ALTB) - Body ground	10 to 14 V
1E-17 (GND) - Body ground	Below 1 Ω

NG REPAIR OR REPLACE HARNESS AND CONNECTOR

OK

REPLACE INSTRUMENT PANEL JUNCTION BLOCK ASSY (MULTIPLEX NETWORK BODY ECU)