

ALL DOORS LOCK/UNLOCK FUNCTIONS DO NOT OPERATE VIA MASTER SWITCH

CIRCUIT DESCRIPTION

The instrument panel J/B Assy (multiplex network body ECU) receives switch signals from the power window regulator master switch Assy and activates the door lock motors on each door according to the signal.

WIRING DIAGRAM

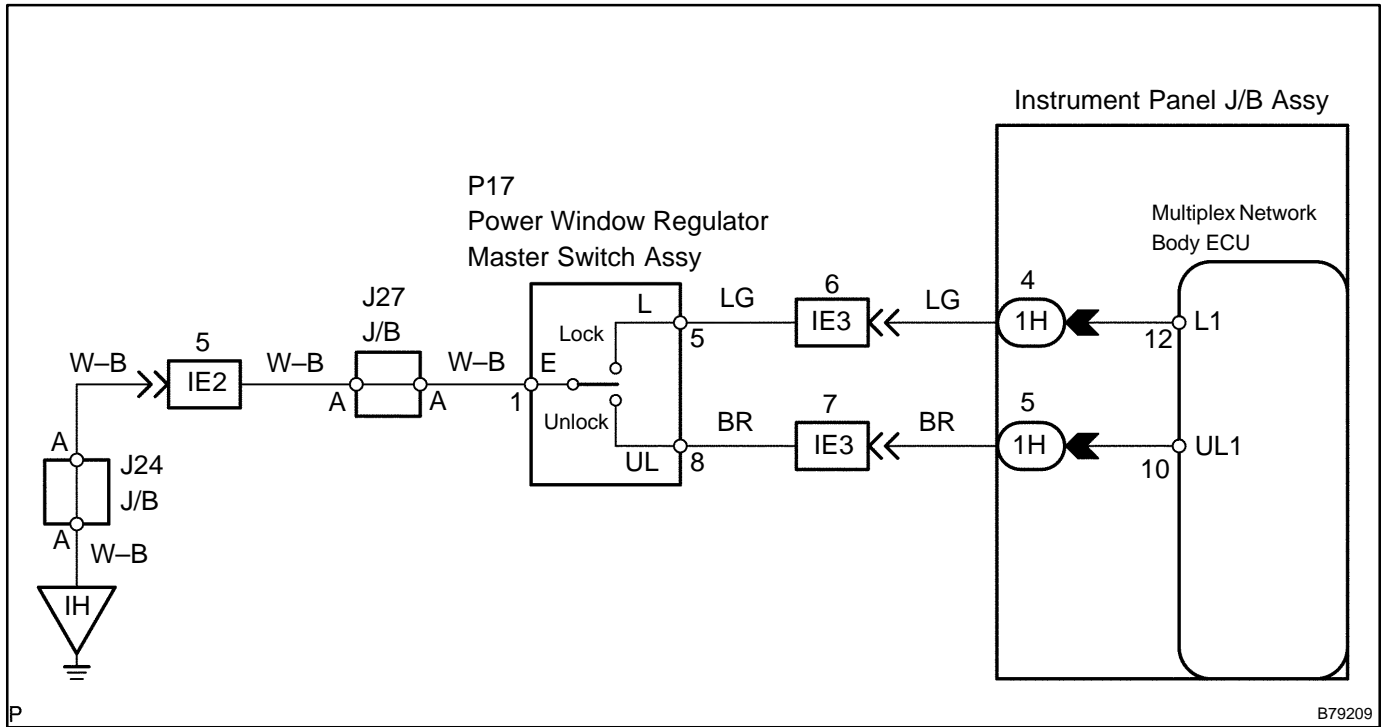

P

B79209

INSPECTION PROCEDURE

1 READ VALUE OF HAND-HELD TESTER (DOOR CONTROL SWITCH)

(a) Check the DATA LIST for proper functioning of the door control switch.

Multiplex network body ECU:

Item	Measurement Item/Display (Range)	Normal Condition	Diagnostic Note
D/L SW-LOCK	Door control switch lock signal /ON or OFF	ON: Door control switch is in lock position OFF: Door control switch is not in lock position	-
D/L SW-UNLOCK	Door control switch unlock signal /ON or OFF	ON: Door control switch is in unlock position OFF: Door control switch is not in unlock position	-

OK: "ON" (door is locked/unlocked) appears on the screen.

NG Go to step 2

OK

REPLACE INSTRUMENT PANEL JUNCTION BLOCK ASSY (MULTIPLEX NETWORK BODY ECU)

2 INSPECT POWER WINDOW REGULATOR MASTER SWITCH ASSY (DOOR CONTROL SWITCH)

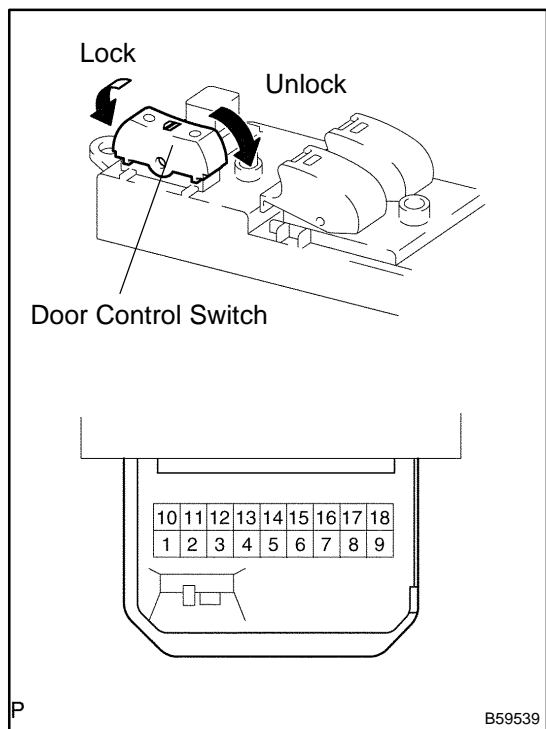

(a) Measure the resistance of the door control switch.

Standard:

Tester Connection	Door Lock Position	Specified Condition
1 - 5	Lock	Below 1 Ω
1 - 5 1 - 8	OFF	10 kΩ or higher
1 - 8	Unlock	Below 1 Ω

NG REPLACE POWER WINDOW REGULATOR MASTER SWITCH ASSY

OK

3 CHECK WIRE HARNESS (POWER WINDOW REGULATOR MASTER SWITCH ASSY (DOOR CONTROL SWITCH) – INSTRUMENT PANEL J/B ASSY AND BODY GROUND)

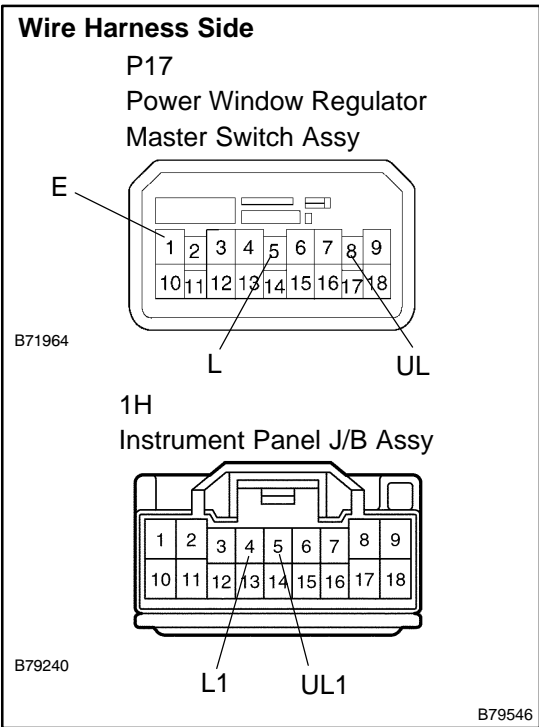

- (a) Disconnect the P17 switch and 1H J/B connectors.
- (b) Measure the resistance of the wire harness side connectors.

Standard:

Tester Connection	Specified Condition
P17-5 (L) – 1H-4 (L1)	Below 1 Ω
P17-8 (UL) – 1H-5 (UL1)	Below 1 Ω
P17-1 (E) – Body ground	Below 1 Ω

NG → **REPAIR OR REPLACE HARNESS AND CONNECTOR**

OK

REPLACE INSTRUMENT PANEL JUNCTION BLOCK ASSY (MULTIPLEX NETWORK BODY ECU)