

DTC	P1121	COOLANT FLOW CONTROL VALVE POSITION SENSOR CIRCUIT STUCK
------------	--------------	---

HINT:

- Although each DTC title says "Coolant Flow Control Valve", these DTCs are related to the water valve.
- CHS stands for Coolant Heat Storage.

CIRCUIT DESCRIPTION

Refer to DTC P1120 on page [05-277](#).

DTC No.	Detection Condition	Trouble Area
P1121	<ul style="list-style-type: none"> • Water valve position sensor output voltage: No change despite the ECM sending a valve control signal or slow response • CHS tank outlet temperature sensor output: 60°C or more (when hot coolant recovering starts) • CHS tank outlet temperature sensor output: No change despite the hot coolant is recovered 	<ul style="list-style-type: none"> • Water valve • Cooling system (clogging) • ECM

MONITOR DESCRIPTION

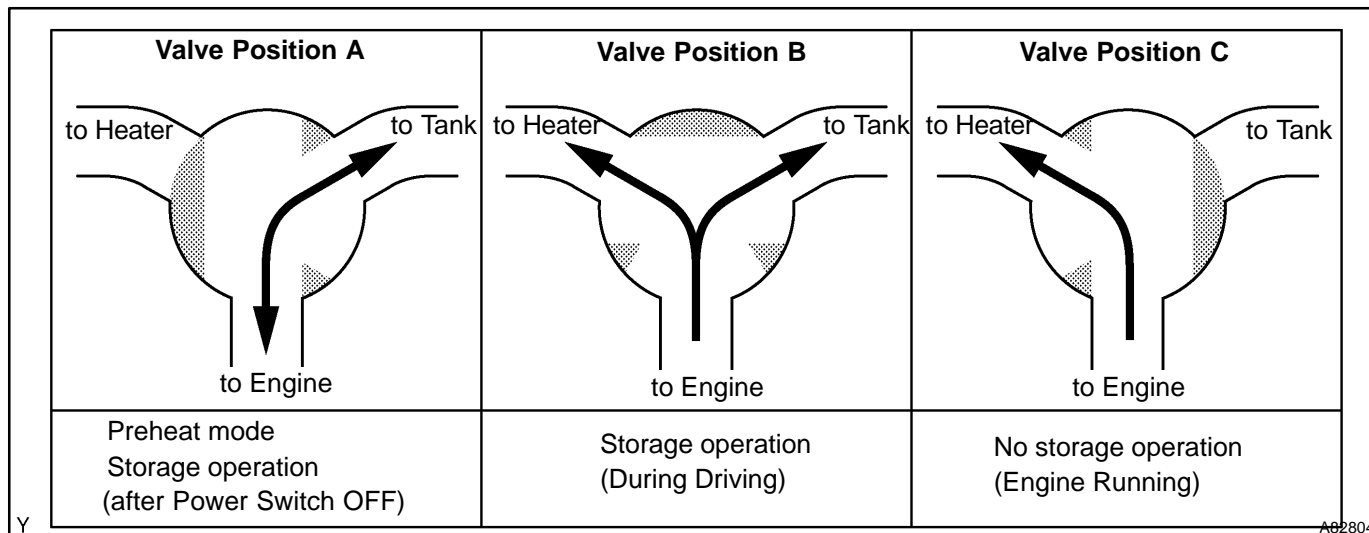

The ECM monitors the position of the water valve based on the valve position signal that is output by the water valve position sensor (potentiometer), which is coupled coaxially to the valve. The water valve effects control in three steps as indicated above, and the ECM determines the position of the valve according to the voltage of the respective step.

In order to ensure the proper monitoring of the water valve, the ECM checks for malfunctions with the combination of the output of the potentiometer and CHS tank outlet temperature sensor.

If no changes occur in the valve position signal that is being input into the ECM or if the response signal from the water valve is very slow, despite of the ECM commanding the water valve motor to operate the ECM determines that malfunction has occurred in the water valve position sensor circuit, and sets a DTC.

MONITOR STRATEGY

Potentiometer detection

Related DTCs	P1121: Coolant flow control valve position sensor circuit stuck
Required sensors/components	Main: Water valve Related: CHS tank outlet temperature sensor
Frequency of operation	Once per driving cycle
Duration	20 seconds
MIL operation	1 driving cycle
Sequence of operation	None

Tank outlet coolant temperature detection

Related DTCs	P1121: Coolant flow control valve position sensor circuit stuck
Required sensors/components	Main: Water valve Related: CHS tank outlet temperature sensor
Frequency of operation	Once per driving cycle
Duration	10 seconds
MIL operation	2 driving cycles
Sequence of operation	None

TYPICAL ENABLING CONDITIONS

Potentiometer detection

The monitor will run whenever the following DTCs are not present	See page 05-20
Coolant heat storage system malfunction	Not detected
Battery voltage	10 V or more
Engine coolant temperature	0°C (32°F) or more
Water valve operation	Commanded
Response time of valve movement	Time under calculation with valve position

Tank outlet coolant temperature detection

The monitor will run whenever the following DTCs are not present	See page 05-20
Coolant heat storage system malfunction	Not detected
Battery voltage	10 V or more
System status	During recovering
CHS tank outlet temperature difference between preheating start and engine start	20°C (36 °F) or more
Difference between engine coolant temperature and CHS tank outlet temperature	30°C (54 °F) or more

TYPICAL MALFUNCTION THRESHOLDS

Potentiometer detection

Either of the following conditions is met:	(a) or (b)
(a) Potentiometer output difference [D divided C] C: Difference between previous and current target D: Difference between potentiometer output and previous target	10 % or more
(b) Potentiometer output deviation from target	0.1 V or more

Tank outlet coolant temperature detection

Either of the following conditions is met:	(a) or (b)
(a) Heat storage tank outlet coolant temperature when re-cover starts	60°C (108 °F) or more
(b) Heat storage tank outlet coolant temperature difference during water valve check	Less than 3°C (5.4 °F)

WIRING DIAGRAM

Refer to DTC P1120 on page [05–277](#).

INSPECTION PROCEDURE

CAUTION:

Be careful when replacing any part in the system or changing the coolant because the coolant in the heat storage tank is hot even if the engine is cold.

HINT:

- If DTCs P1121 and P1150 are detected simultaneously, there may be malfunction in the water valve system.
- If DTC P1121 is detected, coolant passages may be clogged.
- To check the coolant heat storage (CHS) system, the ECM may cause the water pump of the CHS system to operate 5 hours after the power switch has been turned OFF.
- Read freeze frame data using the intelligent tester II. Freeze frame data records the engine condition when malfunction is detected. When troubleshooting, it is useful for determining whether the vehicle was running or stopped, the engine was warmed up or not, the air–fuel ratio was lean or rich, etc. at the time of the malfunction.

Hand-held tester:**1 CHECK OTHER DTC OUTPUT(IN ADDITION TO DTC P1121)**

- (a) Connect the hand-held tester to the DLC3.
- (b) Turn the power switch ON (IG).
- (c) Turn the hand-held tester ON.
- (d) On the hand-held tester, select the item: DIAGNOSIS / ENHANCED OBD II / ENGINE AND ECT / DTC INFO / CURRENT CODES.
- (e) Read DTCs.

Result:

Display (DTC Output)	Proceed to
P1121	A
P1121 and other DTCs	B

HINT:

If any other codes besides P1121 are output, perform troubleshooting for those DTCs first.

B

GO TO RELEVANT DTC CHART
(See page 05-55)

A**2 PERFORM ACTIVE TEST BY HAND-HELD TESTER**

- (a) Connect the hand-held tester to the DLC3.
- (b) Turn the power switch ON (IG).
- (c) Turn the hand-held tester ON.
- (d) Put the engine in inspection mode (see page 05-1).
- (e) Start the engine and warm it up.
- (f) Select the items: DIAGNOSIS / ENHANCED OBD II / ENGINE AND ECT / ACTIVE TEST / WATER FLW VLV3, WATER FLW VLV4 or WATER FLW VLV5.
- (g) Measure the voltage between terminals WBAD and E2 of the ECM connector.

Standard:

Tester Operation	Specified Condition
"WATER FLW VLV 3" ON	Approximately 2.5 V
"WATER FLW VLV 4" ON	Approximately 3.5 V
"WATER FLW VLV 5" ON	Approximately 4.5 V

NG

REPLACE WATER W/BRACKET VALVE ASSY

OK**3 CHECK COOLING SYSTEM**

OK: Coolant passages are not clogged.

NG

REPAIR OR REPLACE COOLING SYSTEM

OK

REPLACE ECM (See page 10-24)

OBD II scan tool (excluding hand-held tester):

1 CHECK OTHER DTC OUTPUT(IN ADDITION TO DTC P1121)

- (a) Connect the OBD II scan tool to the DLC3.
- (b) Turn the power switch ON (IG).
- (c) Turn the OBD II scan tool ON.
- (d) Read DTCs using the OBD II scan tool.

Result:

Display (DTC Output)	Proceed to
P1121	A
P1121 and other DTCs	B

HINT:

If any other codes besides P1121 are output, perform troubleshooting for those DTCs first.

B **GO TO RELEVANT DTC CHART**
(See page 05-55)

A

2 CHECK COOLING SYSTEM

NG **REPAIR OR REPLACE COOLING SYSTEM**

OK

3 CHECK HARNESS AND CONNECTOR(WATER VALVE - ECM)

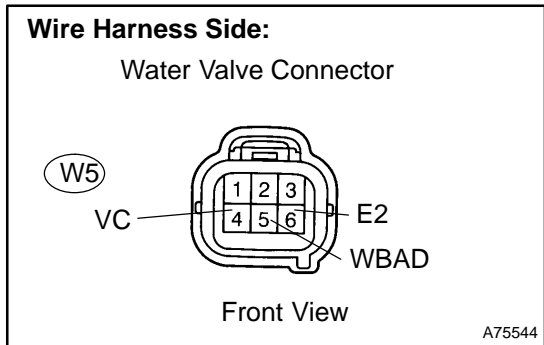

- (a) Disconnect the W5 water valve connector.
- (b) Disconnect the E4 and E7 ECM connectors.
- (c) Check the resistance between the wire harness side connectors.

Standard (Check for open):

Tester Connection	Specified Condition
Water valve (W5-5) - WBAD (E7-20)	Below 1 Ω
Water valve (W5-4) - VC (E4-18)	Below 1 Ω
Water valve (W5-6) - E2 (E4-28)	Below 1 Ω

Standard (Check for short):

Tester Connection	Specified Condition
Water valve (W5-5) or WBAD (E7-20) - Body ground	10 kΩ or higher

- (d) Reconnect the water valve connector.
- (e) Reconnect the ECM connectors.

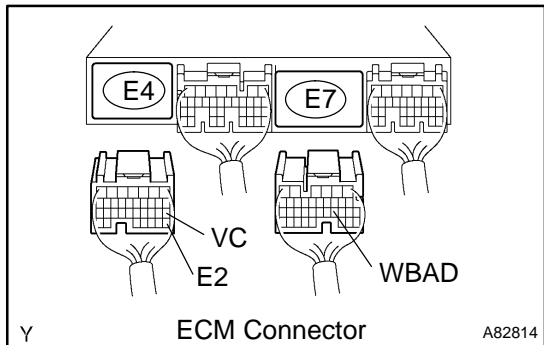

NG **REPAIR OR REPLACE HARNESS OR CONNECTOR**

OK

4 REPLACE WATER W/BACKET VALVE ASSY

GO

5 PERFORM SIMULATION TEST

- (a) Put the engine in inspection mode and start the engine.
- (b) Warm up the engine until the engine coolant temperature reaches more than 90°C (185°F).
- (c) Cool the engine down completely.
- (d) Perform the processes (a) to (c) twice.

GO

6 CHECK IF DTC OUTPUT RECURS

- (a) Connect the OBD II scan tool to the DLC3.
- (b) Turn the power switch ON (IG).
- (c) Turn the OBD II scan tool ON.
- (d) Read DTCs using the OBD II scan tool.

Result:

Display (DTC Output)	Proceed to
No output	A
P1121	B

B **REPLACE ECM (See page 10-24)**

A

SYSTEM OK