

DTC	P0A60/288	DRIVE MOTOR "A" PHASE V CURRENT
DTC	P0A60/289	DRIVE MOTOR "A" PHASE V CURRENT
DTC	P0A60/290	DRIVE MOTOR "A" PHASE V CURRENT
DTC	P0A60/292	DRIVE MOTOR "A" PHASE V CURRENT
DTC	P0A60/294	DRIVE MOTOR "A" PHASE V CURRENT
DTC	P0A60/501	DRIVE MOTOR "A" PHASE V CURRENT
DTC	P0A63/296	DRIVE MOTOR "A" PHASE W CURRENT
DTC	P0A63/297	DRIVE MOTOR "A" PHASE W CURRENT
DTC	P0A63/298	DRIVE MOTOR "A" PHASE W CURRENT
DTC	P0A63/300	DRIVE MOTOR "A" PHASE W CURRENT
DTC	P0A63/302	DRIVE MOTOR "A" PHASE W CURRENT
DTC	P0A63/502	DRIVE MOTOR "A" PHASE W CURRENT

CIRCUIT DESCRIPTION

See the description of the inverter on page 05-562.

The motor inverter current sensors detect the amperage that flows through the V and W phase cables between the inverter and MG1/MG2. The inverter transmits information that is necessary for effecting control, such as the amperage and voltage, to the HV control ECU.

The HV control ECU monitors the inverter current sensors to detect a malfunction in the sensor system. Thus, this does not intend detecting a malfunction in the high voltage system.

DTC No.	INF Code	DTC Detection Condition	Trouble Area
P0A60	288	Phase V current sub sensor of motor inverter current sensor malfunction	<ul style="list-style-type: none"> • Wire harness or connector • w/ converter inverter assembly
P0A60	289	Open in phase V current sub sensor circuit of motor inverter current sensor	<ul style="list-style-type: none"> • Wire harness or connector • w/ converter inverter assembly
P0A60	290	Phase V current main sensor of motor inverter current sensor malfunction	<ul style="list-style-type: none"> • Wire harness or connector • w/ converter inverter assembly
P0A60	292	Open in phase V current main sensor circuit of motor inverter current sensor	<ul style="list-style-type: none"> • Wire harness or connector • w/ converter inverter assembly
P0A60	294	Phase V current main and sub sensors of motor inverter current sensor performance problem	<ul style="list-style-type: none"> • Wire harness or connector • w/ converter inverter assembly
P0A60	501	Phase V current main and sub sensors of motor inverter current sensor offset malfunction	<ul style="list-style-type: none"> • Wire harness or connector • w/ converter inverter assembly
P0A63	296	Phase W current sub sensor of motor inverter current sensor malfunction	<ul style="list-style-type: none"> • Wire harness or connector • w/ converter inverter assembly
P0A63	297	Open in phase W current sub sensor circuit of motor inverter current sensor	<ul style="list-style-type: none"> • Wire harness or connector • w/ converter inverter assembly
P0A63	298	Phase W current main sensor of motor inverter current sensor malfunction	<ul style="list-style-type: none"> • Wire harness or connector • w/ converter inverter assembly
P0A63	300	Open in phase W current main sensor circuit of motor inverter current sensor	<ul style="list-style-type: none"> • Wire harness or connector • w/ converter inverter assembly
P0A63	302	Phase W current main and sub sensors of motor inverter current sensor performance problem	<ul style="list-style-type: none"> • Wire harness or connector • w/ converter inverter assembly
P0A63	502	Phase W current main and sub sensors of motor inverter current sensor offset malfunction	<ul style="list-style-type: none"> • Wire harness or connector • w/ converter inverter assembly

MONITOR DESCRIPTION

The HV control ECU monitors the motor inverter current sensor. If the HV control ECU detects a fault, it will illuminate the MIL and set a DTC.

MONITOR STRATEGY

Related DTCs	P0A60 (INF 288/289/290/292/294/501): Motor inverter current sensor / Phase V current sensor malfunction P0A63 (INF 296/297/298/300/302/502): Motor inverter current sensor / Phase W current sensor malfunction
Required sensor/components	Motor inverter current sensor, motor resolver
Frequency of operation	Continuous
Duration	TOYOTA's intellectual property
MIL operation	Immediately
Sequence of operation	None

TYPICAL ENABLING CONDITIONS

The monitor will run whenever the following DTCs are not present	TOYOTA's intellectual property
Other conditions belong to TOYOTA's intellectual property	–

TYPICAL MALFUNCTION THRESHOLDS

Motor inverter current sensor	Abnormal
-------------------------------	----------

COMPONENT OPERATING RANGE

P0A60 (INF 288/289/290/292/294/501):

Motor inverter current sensor	DTC P0A60 (INF 288/289/290/292/294/501) is not detected
-------------------------------	---

P0A63 (INF 296/297/298/300/302/502):

Motor inverter current sensor	DTC P0A63 (INF 296/297/298/300/302/502) is not detected
-------------------------------	---

WIRING DIAGRAM

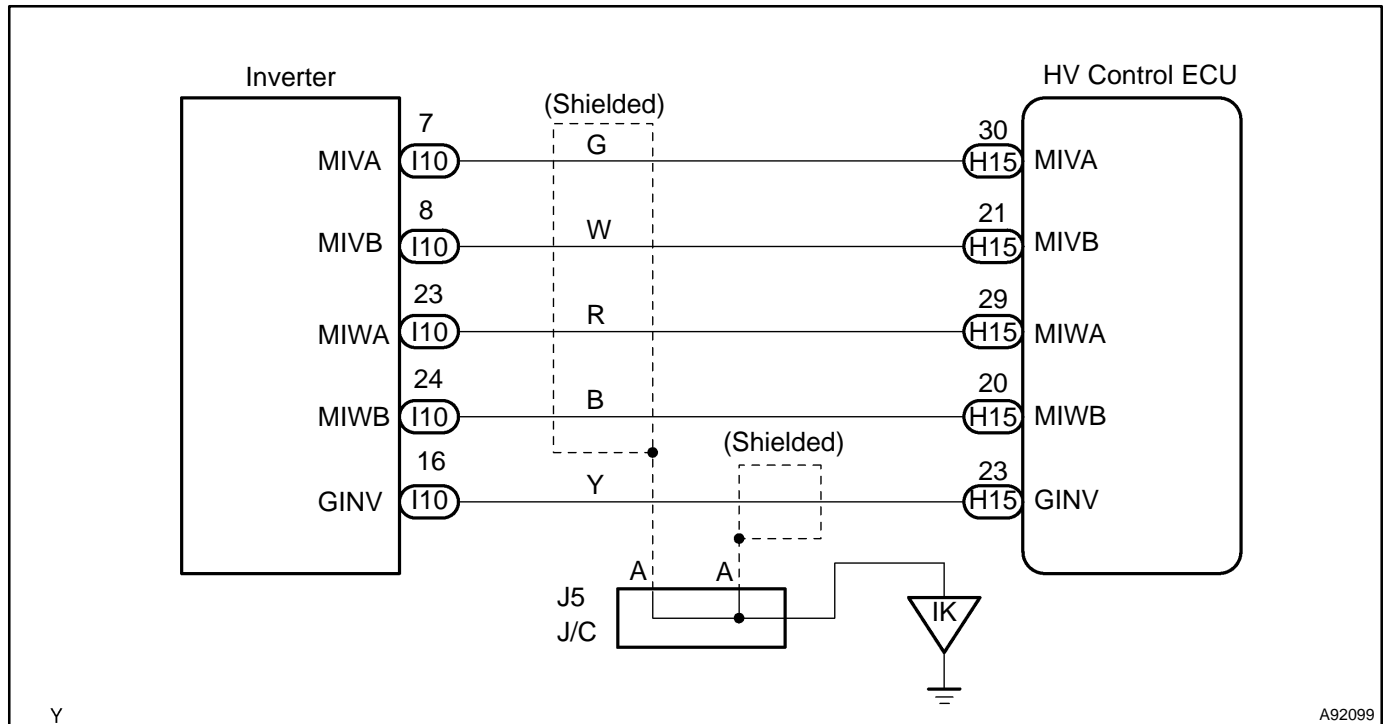

INSPECTION PROCEDURE

CAUTION:

- Before inspecting the high-voltage system, take safety precautions to prevent electrical shocks, such as wearing insulated gloves and removing the service plug grip. After removing the service plug grip, put it in your pocket to prevent other technicians from reconnecting it while you are servicing the high-voltage system.
- After disconnecting the service plug grip, wait at least for 5 minutes before touching any of the high-voltage connectors or terminals.

HINT:

At least 5 minutes is required to discharge the high-voltage condenser inside the inverter.

1 CHECK HARNESS AND CONNECTOR(HYBRID VEHICLE CONTROL ECU - INVERTER)

CAUTION:

Wear insulated gloves before performing the following operation.

- (a) Turn the power switch OFF.
- (b) Remove the service plug grip (see page 21-116).

NOTICE:

Turning the power switch ON (READY) with the service plug grip removed could cause malfunction. Therefore, never turn the power switch ON (READY) in this state.

- (c) Disconnect the H15 HV control ECU connector.
- (d) Remove the inverter cover (see page 21-23).
- (e) Disconnect the I10 inverter connector.
- (f) Turn the power switch ON (IG).

HINT:

DTCs for the interlock switch system are output when turning the power switch ON (IG) with both service plug grip and inverter cover removed.

- (g) Measure the voltage between the terminals of the HV control ECU connector and body ground.

Standard:

Tester Connection	Specified Condition
MIVA (H15-30) - Body ground	Below 1 V
MIVB (H15-21) - Body ground	Below 1 V
MIWA (H15-29) - Body ground	Below 1 V
MIWB (H15-20) - Body ground	Below 1 V
GINV (H15-23) - Body ground	Below 1 V

- (h) Turn the power switch OFF.
- (i) Check the resistance between the wire harness side connectors.

Standard (Check for open):

Tester Connection	Specified Condition
MIVA (H15-30) - MIVA (I10-7)	Below 1 Ω
MIVB (H15-21) - MIVB (I10-8)	Below 1 Ω
MIWA (H15-29) - MIWA (I10-23)	Below 1 Ω
MIWB (H15-20) - MIWB (I10-24)	Below 1 Ω
GINV (H15-23) - GINV (I10-16)	Below 1 Ω

Standard (Check for short):

Tester Connection	Specified Condition
MIVA (H15-30) or MIVA (I10-7) - Body ground	10 kΩ or higher
MIVB (H15-21) or MIVB (I10-8) - Body ground	10 kΩ or higher
MIWA (H15-29) or MIWA (I10-23) - Body ground	10 kΩ or higher
MIWB (H15-20) or MIWB (I10-24) - Body ground	10 kΩ or higher
GINV (H15-23) or GINV (I10-16) - Body ground	10 kΩ or higher

- (j) Reconnect the inverter connector.
- (k) Reconnect the HV control ECU connector.
- (l) Reinstall the inverter cover (see page 21-23).
- (m) Reinstall the service plug grip (see page 21-116).

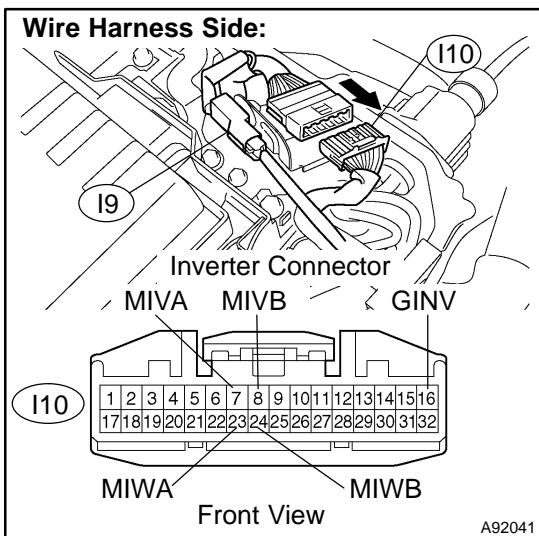
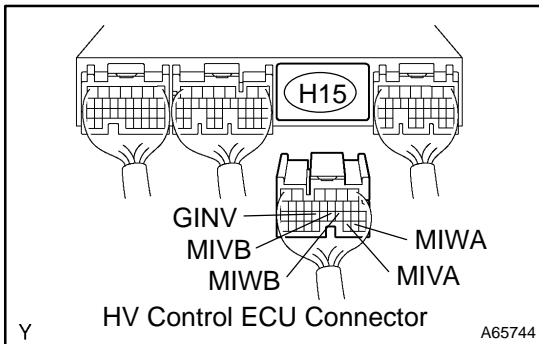

NG

REPAIR OR REPLACE HARNESS OR
CONNECTOR

OK

REPLACE W/CONVERTER INVERTER ASSY (See page [21-23](#))