

CALIBRATION

1. DESCRIPTION

- (a) Zero point calibration is not performed until the data is cleared when the zero point is once stored. Zero point calibration should be performed after the zero point is cleared if the yaw rate (deceleration) sensor is replaced.
- (b) Steering sensor zero point calibration is automatically performed with the vehicle driving straight.
- (c) Follow the chart to perform calibration.

Replacing Parts	Necessary Operation
Skid Control ECU	Yaw rate (deceleration) sensor zero point calibration.
Yaw Rate (deceleration) sensor	2. Clearing zero point calibration data. 3. Yaw rate sensor and deceleration sensor zero point calibration.

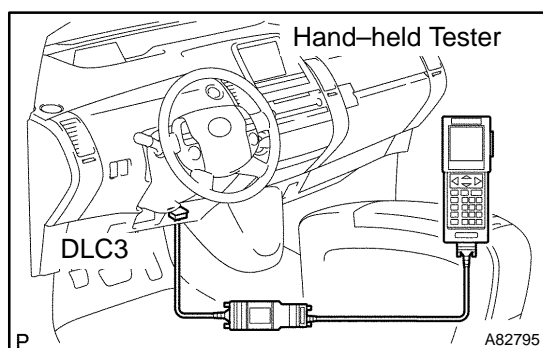

2. CLEAR ZERO POINT CALIBRATION

- (a) Clearing the DTCs.
 - (1) Connect the hand-held tester to the DLC3.
 - (2) Turn the power switch ON (READY).
 - (3) Operate the hand-held tester to erase the codes.

HINT:

Refer to the hand-held tester Operator's Manual for further details.

3. PERFORM ZERO POINT CALIBRATION OF YAW RATE SENSOR AND DECELERATION SENSOR

NOTICE:

- **While obtaining the zero point, do not vibrate the vehicle by tilting, moving or shaking it and keep it in a stationary condition. (Do not start the engine.)**
 - **Be sure to do this on a level surface (with an inclination less than 1 degree).**
- (a) Check that the steering wheel is in the straight-ahead position and move the shift lever to the P position.
 - (b) Connect the hand-held tester to the DLC3.
 - (c) Turn the power switch ON (READY).
 - (d) Operate the hand-held tester to test mode.
 - (e) Obtain the zero point of the yaw rate sensor and deceleration sensor.
 - (1) Keep the vehicle in the stationary condition on a level surface for 2 seconds or more.
 - (2) Check that the VSC warning light blinks.

HINT:

- If the VSC warning light does not blink, perform the zero point calibration again.
 - The zero point calibration is performed only once after the system enters the test mode.
 - Calibration cannot be performed again until the stored data is cleared once.
- (f) Turn the power switch OFF.