

ONLY WIRELESS CONTROL FUNCTION IS INOPERATIVE

CIRCUIT DESCRIPTION

The door control receiver receives signals from the transmitter and sends these signals to the multiplex network body ECU. The multiplex network body ECU then controls all doors by sending LOCK/UNLOCK signals to each door lock actuator.

WIRING DIAGRAM

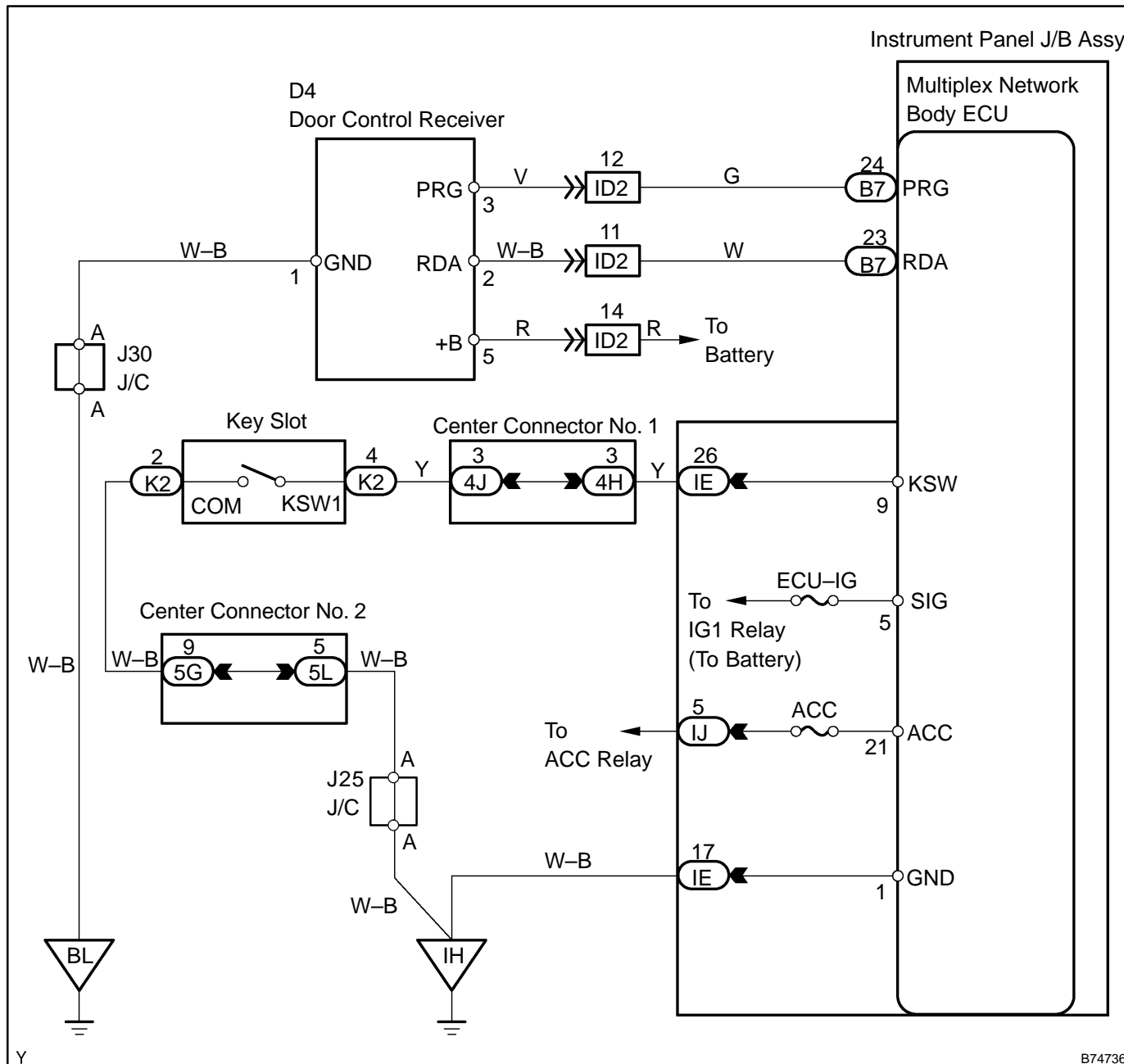

INSPECTION PROCEDURE**1 CHECK WIRELESS DOOR LOCK CONTROL FUNCTIONS (See page 05-2301)****NG** Go to step 2**OK****NORMAL****2 CHECK THAT TRANSMITTER LED LIGHTS UP**

- (a) Check that the transmitter LED lights up 3 times when the switch is pressed 3 times.

OK: Transmitter LED lights up 3 times when the switch is pressed 3 times.**NG** Go to step 4**OK****3 CHECK WIRELESS DOOR LOCK CONTROL FUNCTIONS
(STANDARD OPERATION)**

- (a) Check standard UNLOCK/LOCK switch operation.

NOTICE:

Standardized test procedure: press the transmitter switch for 1 second, directing the beam to the driver side door outside handle from a distance of 1 m (39.4 in.). The transmitter should be pointed directly at the handle, i.e. at a 90° angle to the vehicle body.

NG Go to step 5**OK****REPLACE DOOR CONTROL TRANSMITTER****4 REPLACE TRANSMITTER BATTERY**

- (a) After replacing the transmitter battery, check that the doors can be locked and unlocked by using the transmitter LOCK/UNLOCK switch.

OK: Doors can be locked and unlocked with transmitter.**NG** REPLACE DOOR CONTROL TRANSMITTER**OK****END**

5 SWITCH TO SELF-DIAGNOSTIC MODE

- (a) Switch self-diagnosis mode on the hand-held tester.
 - (1) Connect the hand-held tester to the DLC3.
 - (2) Change the power switch's power mode to ON (IG) by pushing the power switch and push the hand-held test main switch ON.
 - (3) Please refer to the hand-held tester operator's manual for further details.
- (b) Switch self-diagnosis mode by operating the key slot.
 - (1) Put the vehicle under the vehicle's initial condition (see page 05-2301), insert the key into the key slot and remove it.
 - (2) Within 5 seconds after the key is removed (step 1), insert the key into the key slot. Then change the power switch's power mode to ON (IG) and OFF by pushing the power switch.
 - (3) Within 30 seconds after the power switch's power mode OFF again (step 2), perform the following 9 times: Change the power switch's power mode to ON (IG) and OFF by pushing the power switch (step 3).

NOTICE:

If the change to-self-diagnostic mode has failed, the system will return to normal mode.

HINT:

- Changing the power switch's power mode to ON (IG) by pushing the power switch after step 3 has been completed will end self-diagnostic mode.
- Do not lock or unlock doors during the self-diagnostic mode.

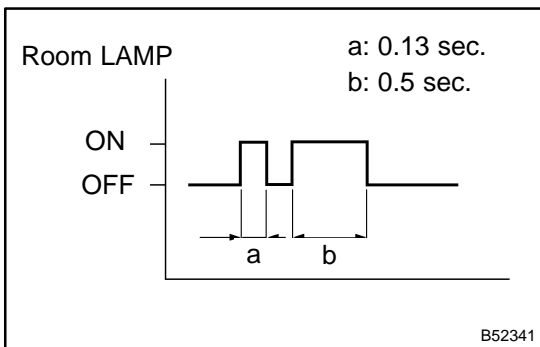

- (c) Check that the system has switched to self-diagnostic mode by checking the flashes of the room lamp (dome lamp or key slot light) or buzzer outputs. Compare the flash patterns of the room lamp and output patterns of the buzzer to the timing chart on the left.

OK: The flash patterns of the room lamp and output patterns of the buzzer should be the same as that shown in the timing chart on the left.

NG Go to step 9

OK

6 CHECK BY SELF-DIAGNOSTIC MODE

(a) Inspect the diagnosis outputs when the door control transmitter switch is held down. The diagnosis outputs can be checked by the flash patterns of the room lamp and output patterns of the buzzer.

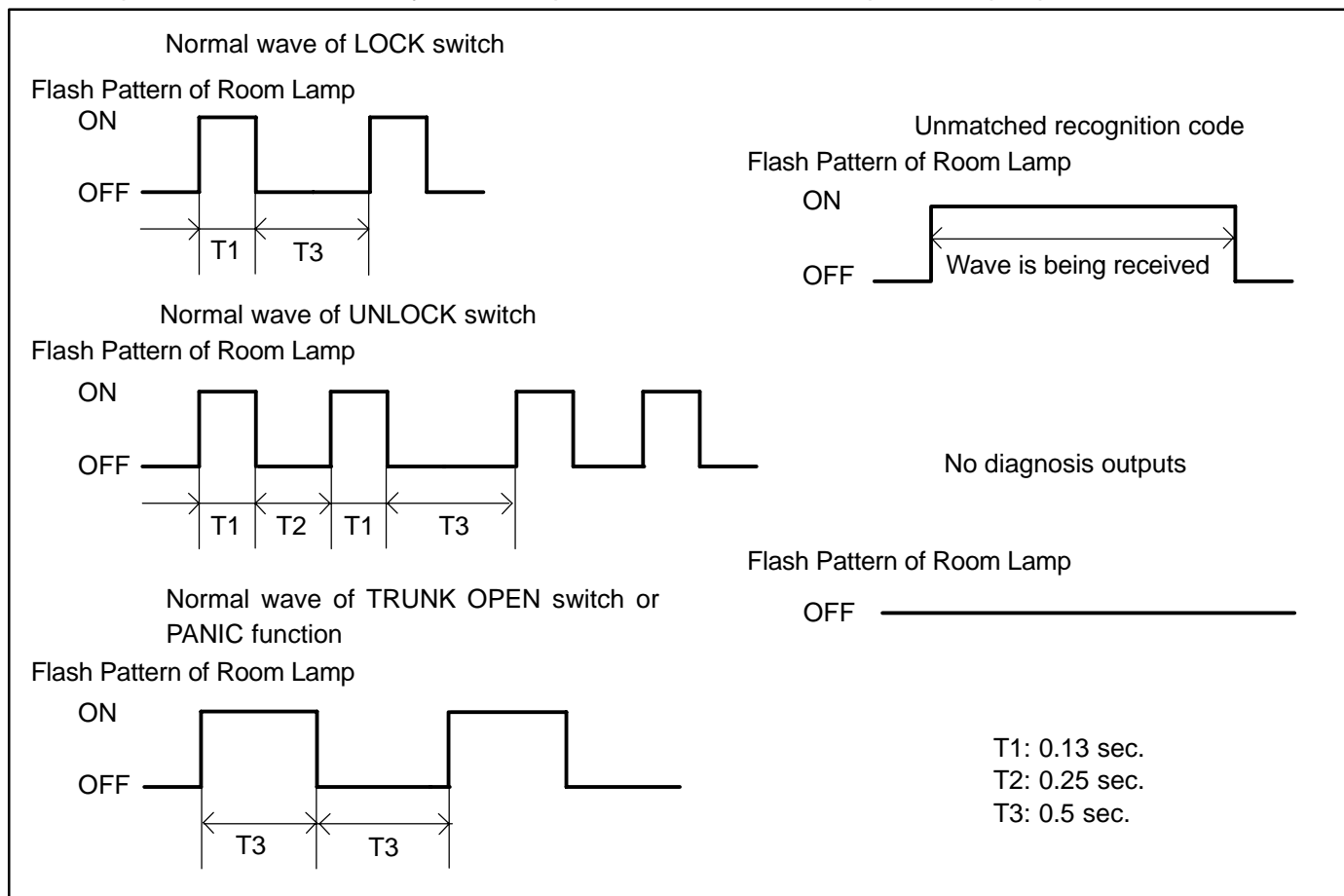

Result	Proceed to
When unmatched recognition code is output.	A
When normal waves (patterns of room lamp and output patterns of buzzer) for LOCK, UNLOCK and PANIC switches are output.	B
When no diagnosis outputs are present.	C

B → **REPLACE INSTRUMENT PANEL JUNCTION BLOCK ASSY**

C → **Go to step 12**

A

7 REGISTER RECOGNITION CODE

- (a) Check that the system can switch to rewrite mode or add mode, and that a recognition code can be registered.

OK:

System can switch to rewrite mode or add mode, and that a recognition code can be registered.

NG → **Go to step 8**

OK

END

8 REPLACE DOOR CONTROL RECEIVER

- (a) After replacing the door control receiver, check that the doors can be locked and unlocked by using the transmitter LOCK/UNLOCK switch.

OK: Doors can be locked and unlocked with transmitter.

NG → **REPLACE INSTRUMENT PANEL JUNCTION BLOCK ASSY**

OK

END

9 CONFIRM INPUT METHOD OF SELF-DIAGNOSTIC MODE

Result	Proceed to
When the method for changing the system self-diagnostic mode works.	A
When the method for changing the system self-diagnostic mode does not works.	B

B → **Go to step 5**

A

10 INSPECT KEY SLOT

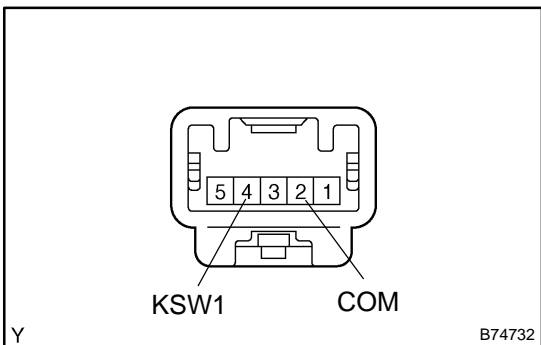

- (a) Measure the resistance of the halfway switch.

Standard:

Tester Connection	Condition	Specified Condition
K2-4 (KSW1) – K2-2 (COM)	No key is in key slot	10 kΩ or higher
K2-4 (KSW1) – K2-2 (COM)	Key is in key slot	Below 1 Ω

NG → **REPAIR OR REPLACE HARNESS AND CONNECTOR**

OK

11 CHECK WIRE HARNESS (KEY SLOT - INSTRUMENT PANEL JUNCTION BLOCK ASSY AND BODY GROUND)

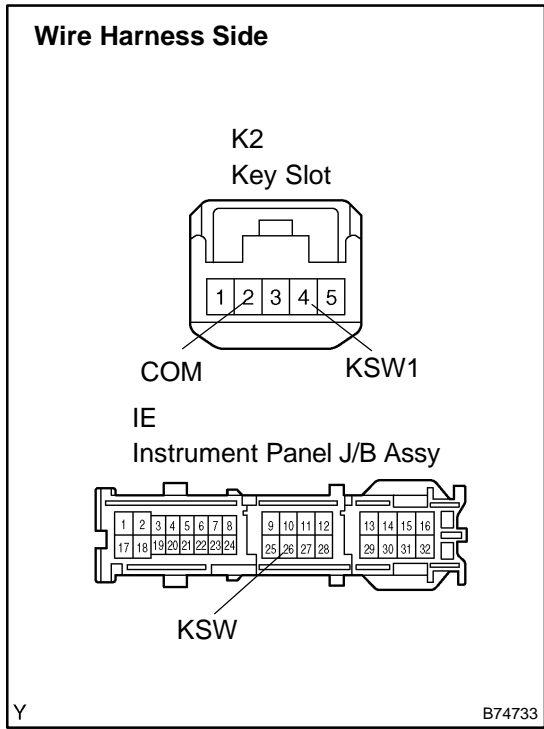

- (a) Disconnect the K2 slot connector.
- (b) Disconnect the IE J/B connector.
- (c) Measure the resistance of the wire harness side connectors.

Standard:

Tester Connection	Specified Condition
K2-4 (KSW1) - IE-26 (KSW)	Below 1 Ω
K2-2 (COM) - Body ground	Below 1 Ω

NG REPAIR OR REPLACE HARNESS AND CONNECTOR

OK

REPLACE INSTRUMENT PANEL JUNCTION BLOCK ASSY

12 CHECK WIRE HARNESS (DOOR CONTROL RECEIVER - BODY GROUND)

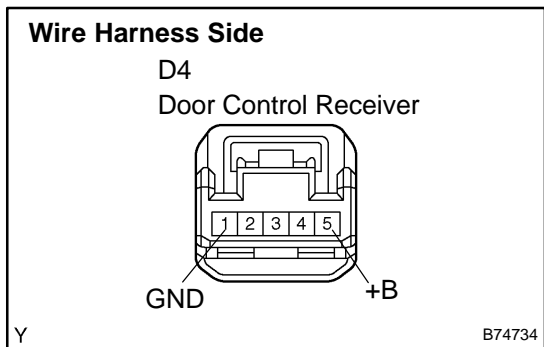

- (a) Disconnect the D4 receiver connector.
- (b) Measure the voltage and resistance between the wire harness side connector and body ground.

Standard:

Tester Connection	Specified Condition
D4-5 (+B) - Body ground	10 to 14 V
D4-1 (GND) - Body ground	Below 1 Ω

NG REPAIR OR REPLACE WIRE HARNESS AND CONNECTOR

OK

13 CHECK WIRE HARNESS (DOOR CONTROL RECEIVER – MULTIPLEX NETWORK BODY ECU) (DOOR CONTROL RECEIVER OR MULTIPLEX NETWORK BODY ECU – BODY GROUND)

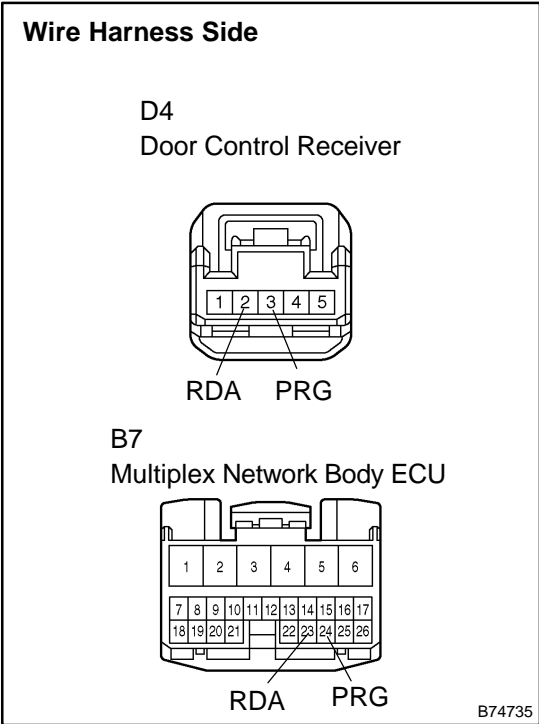

- (a) Disconnect the D4 receiver connector.
- (b) Disconnect the B7 ECU connector.
- (c) Measure the resistance of the wire harness side connectors.

Standard:

Tester Connection	Specified Condition
D4–2 (RDA) – B7–23 (RDA)	Below 1 Ω
D4–3 (PRG) – B7–24 (PRG)	Below 1 Ω
D4–2 (RDA) or B7–23 (RDA) – Body ground	10 kΩ or higher
D4–3 (PRG) or B7–24 (PRG) – Body ground	10 kΩ or higher

NG REPAIR OR REPLACE WIRE HARNESS AND CONNECTOR

OK

14 CHECK DOOR CONTROL RECEIVER (OUTPUT)

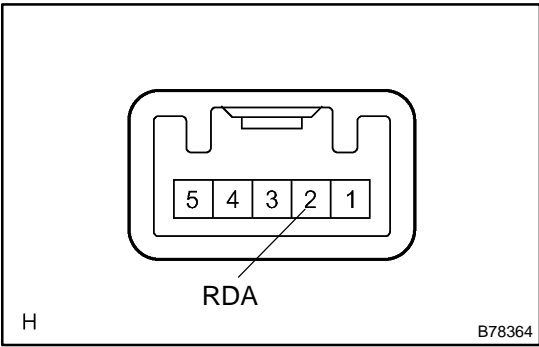

- (a) Reconnect the D4 receiver connector.
- (b) Measure the voltage between the terminal and body ground.

Standard:

Tester Connection	Condition	Specified Condition
D4–4 (DATA) – Body ground	No key in key slot, all doors closed and each transmitter switch OFF ON	Below 1 V Approx. 6 to 7 V below 1 V

NG Go to step 15

OK

REPLACE INSTRUMENT PANEL JUNCTION BLOCK ASSY

15 REPLACE DOOR CONTROL TRANSMITTER

- (a) Check that the doors can be locked and unlocked by using the transmitter LOCK/UNLOCK switch.
OK: Doors can be locked and unlocked with transmitter.

NG**REPLACE DOOR CONTROL RECEIVER****OK****END**