

DTC	P0A9B	HYBRID BATTERY TEMPERATURE SENSOR CIRCUIT
------------	--------------	--

CIRCUIT DESCRIPTION

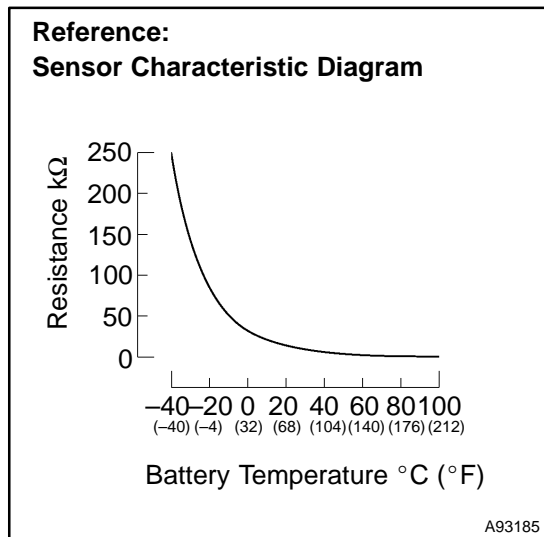

Three battery temperature sensors are located on the bottom of the HV battery assembly. The resistance of the thermistor, which is enclosed in each battery temperature sensor, changes in accordance with the changes in the temperature of the HV battery assembly. The lower the battery temperature, the higher the resistance of the thermistor. Conversely, the higher the temperature, the lower the resistance.

The battery ECU uses the battery temperature sensors to detect the temperature of the HV battery assembly. Based on the results of this detection, the battery ECU controls the battery blower assembly. (Thus, the blower fan starts when the HV battery temperature rises to a predetermined level.)

DTC No.	DTC Detection Condition	Trouble Area
P0A9B	<ul style="list-style-type: none"> • Temperature detected by battery temperature sensors is lower than standard (open), or higher than standard (short) (1 trip detection logic) • Malfunction in battery temperature sensor characteristics (1 trip detection logic) 	<ul style="list-style-type: none"> • HV battery assembly (HV battery temperature sensor) • Battery ECU

HINT:

After confirming DTC P0A9B, confirm BATT TEMP 1 to 3 in DIAGNOSIS / ENHANCED OBD II / HV BATTERY / DATA LIST using the hand-held tester or the OBD II scan tool.

Temperature Displayed	Malfunction
-45°C (-49°F) or less	Open or +B short circuit
95°C (203°F) or more	GND short circuit

MONITOR DESCRIPTION

If the temperature indicated by the battery temperature sensors is lower than the standard level (open), or is higher than the standard level (short), the battery ECU interprets this as a sensor malfunction. If the battery ECU detects that HV battery temperature is out of a normal range or its value is abnormal, it illuminates the MIL and sets a DTC.

MONITOR STRATEGY

Related DTCs	P0A9B: Battery temperature sensor/Range check Battery temperature sensor/Rationality
Required sensor/components	Battery temperature sensor
Frequency of operation	Continuous
Duration	TOYOTA's intellectual property
MIL operation	Immediately
Sequence of operation	None

TYPICAL ENABLING CONDITIONS

The monitor will run whenever the following DTCs are not present	TOYOTA's intellectual property
Other conditions belong to TOYOTA's intellectual property	-

TYPICAL MALFUNCTION THRESHOLDS

Range check:

Resistance of battery temperature sensor	1.108 kΩ or less or 247.7 kΩ or more
--	--------------------------------------

Rationality:

Temperature deviation among batteries (Maximum temperature - Minimum temperature)	Exceeds the standard level
--	----------------------------

COMPONENT OPERATING RANGE

Battery temperature sensor	9 to 11 kΩ (at 25°C (77°F))
----------------------------	-----------------------------

WIRING DIAGRAM

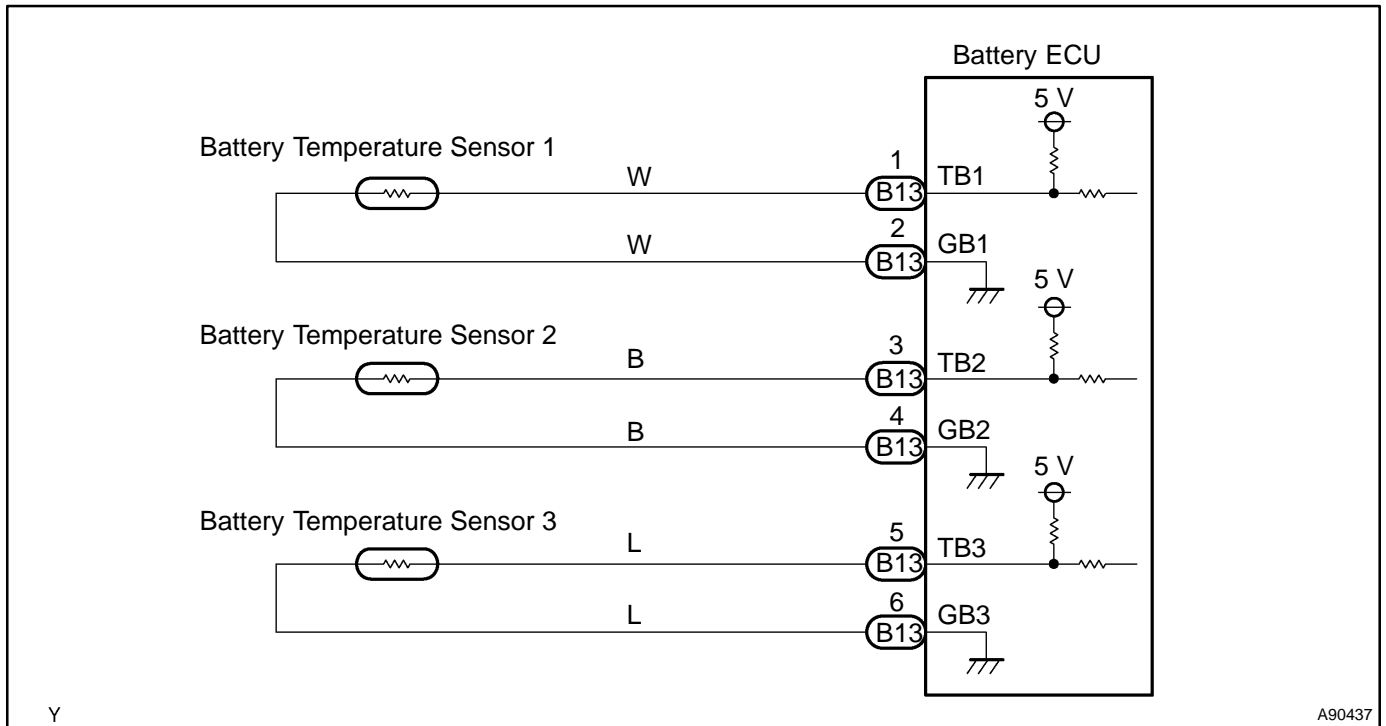

INSPECTION PROCEDURE

CAUTION:

- Before inspecting the high-voltage system, take safety precautions to prevent electrical shocks, such as wearing insulated gloves and removing the service plug grip. After removing the service plug grip, put it in your pocket to prevent other technicians from reconnecting it while you are servicing the high-voltage system.
- After disconnecting the service plug grip, wait at least for 5 minutes before touching any of the high-voltage connectors or terminals.

HINT:

At least 5 minutes is required to discharge the high-voltage condenser inside the inverter.

1 READ OUTPUT DTC(DTC P0A1F IS OUTPUT)

- (a) Connect the hand-held tester or the OBD II scan tool to the DLC3.
- (b) Turn the power switch ON (IG).
- (c) Turn the hand-held tester or the OBD II scan tool ON.
- (d) On the hand-held tester, enter the following menus: DIAGNOSIS / ENHANCED OBD II / HV BATTERY / DTC INFO / TROUBLE CODES.
For the OBD II scan tool, see its instruction manual.
- (e) Read DTCs.
Result: DTC P0A1F is output

YES → **REPLACE BATTERY ECU ASSY**
(See page 21-98)

NO

2 CHECK CONNECTION OF BATTERY TEMPERATURE SENSOR CONNECTOR

CAUTION:

Wear insulated gloves before performing the following operation.

- (a) Turn the power switch OFF.
- (b) Remove the service plug grip (see page 21-116).

NOTICE:

Turning the power switch ON (READY) with the service plug grip removed could cause malfunction. Therefore, never turn the power switch ON (READY) in this state.

- (c) Check the connection condition of the B13 battery ECU connector.

OK: Connector has been connected securely and there is no poor connection.

HINT:

Since the battery temperature sensor is not available as a unit and if replacement is required, replace the entire HV battery assembly.

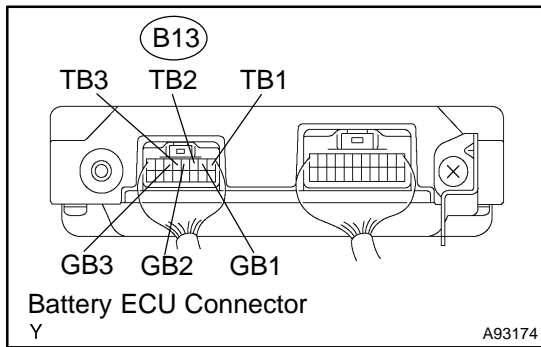

NG → **CONNECT SECURELY**

OK

REPLACE HV SUPPLY BATTERY ASSY (See page 21-54)