

DTC	B1900/73	SHORT IN P/T SQUIB (D SEAT SIDE) CIRCUIT
------------	-----------------	---

CIRCUIT DESCRIPTION

The P/T squib (D seat side) circuit consists of the airbag ECU Assy and the front seat outer belt Assy LH. This circuit instructs the SRS to deploy when deployment conditions are met.

DTC B1900 is recorded when a short circuit is detected in the P/T squib (D seat side) circuit.

DTC No.	DTC Detecting Condition	Trouble Area
B1900	<ul style="list-style-type: none"> • When the airbag ECU Assy receives a line short signal 5 times in the P/T squib (D seat side) circuit during primary check. • P/T squib (D seat side) malfunction • Airbag ECU Assy malfunction 	<ul style="list-style-type: none"> • Floor wire • Front seat outer belt Assy LH (P/T squib (D seat side)) • Airbag ECU Assy

WIRING DIAGRAM

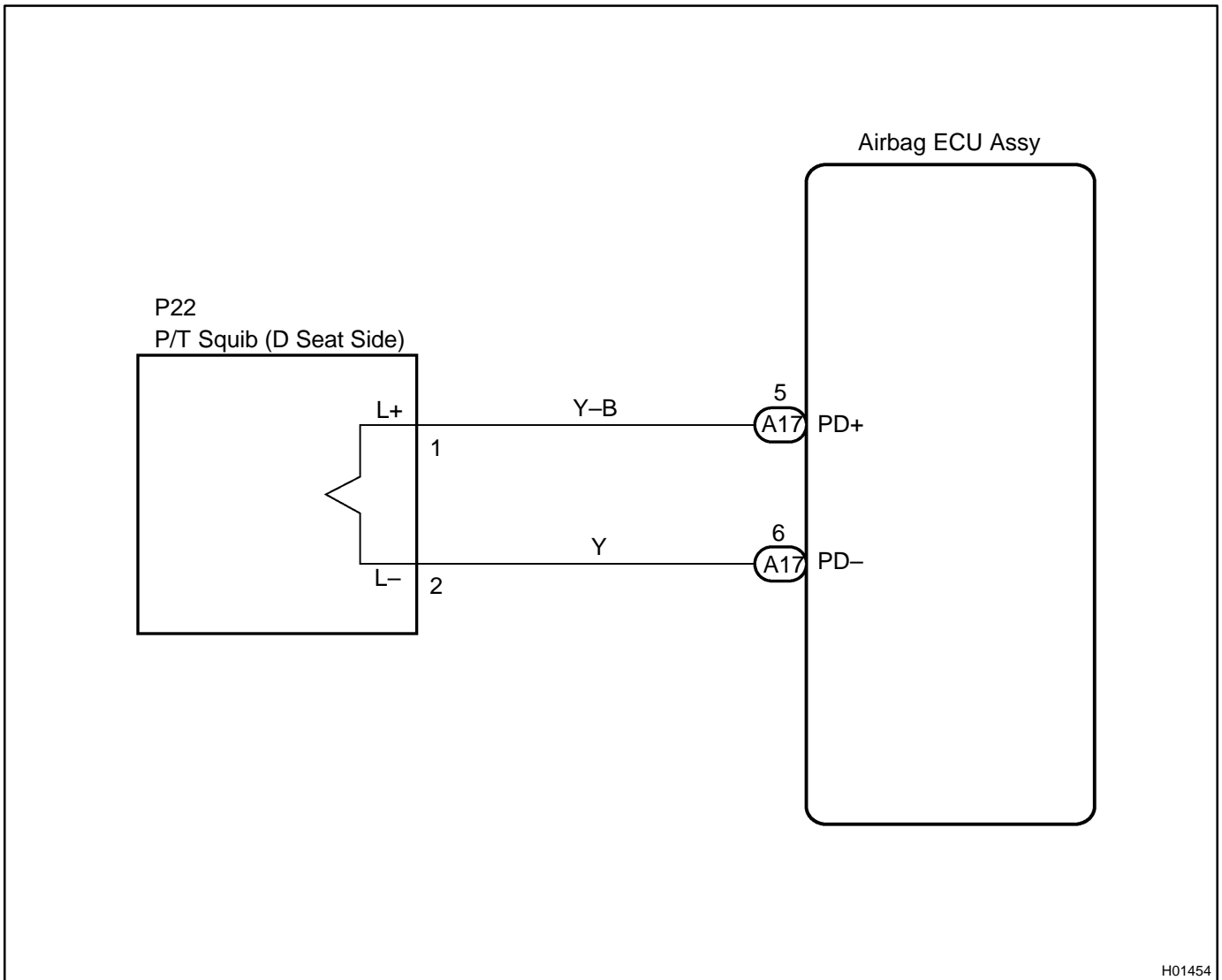

H01454

INSPECTION PROCEDURE

CAUTION:

Be sure to perform the following procedures before troubleshooting to avoid unexpected airbag deployment.

- (a) Turn the power switch off.
- (b) Disconnect the negative (-) terminal cable from the battery, and wait for at least 90 seconds.
- (c) Disconnect the connectors from the airbag ECU Assy.
- (d) Disconnect the connectors from the horn button Assy.
- (e) Disconnect the connectors from the front passenger airbag Assy.
- (f) Disconnect the connector from the front seat airbag Assy LH.
- (g) Disconnect the connector from the front seat airbag Assy RH.
- (h) Disconnect the connector from the curtain shield airbag Assy LH.
- (i) Disconnect the connector from the curtain shield airbag Assy RH.
- (j) Disconnect the connector from the front seat outer belt Assy LH.
- (k) Disconnect the connector from the front seat outer belt Assy RH.

1 CHECK CONNECTOR

- (a) Check that the floor wire connector (on the front seat outer belt Assy LH side) is not damaged.

OK:

The lock button is not disengaged, or the claw of the lock is not deformed or damaged.

NG REPAIR OR REPLACE FLOOR WIRE

OK

2 CHECK FLOOR WIRE(P/T SQUIB (D SEAT SIDE) CIRCUIT)

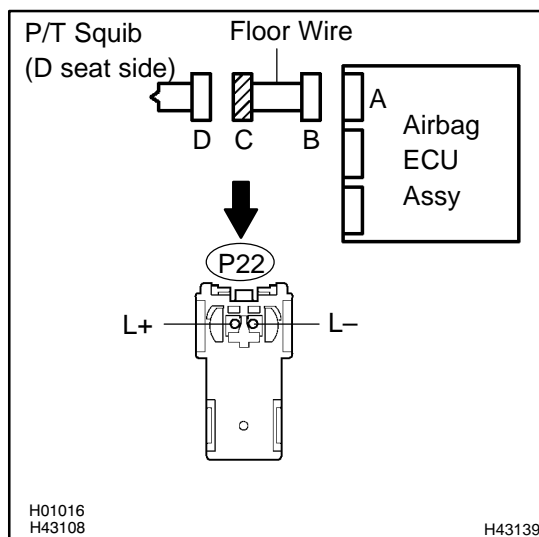

- (a) Release the activation prevention mechanism built into connector "B" (see page 05-1397).

- (b) Measure the resistance according to the value(s) in the table below.

Standard:

Tester connection	Condition	Specified condition
P22-1 (L+) - P22-2 (L-)	Always	1 MΩ or Higher

NG REPAIR OR REPLACE FLOOR WIRE

OK

3 CHECK AIR BAG ECU ASSY

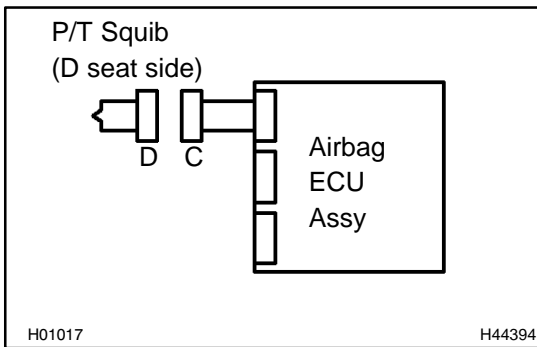

- (a) Connect the connectors to the airbag ECU assy.
- (b) Connect the negative (–) terminal cable to the battery, and wait for at least 2 seconds.
- (c) Turn the power switch on (IG), and wait for at least 60 seconds.
- (d) Clear the DTCs stored in memory (see page 05-1402).
- (e) Turn the power switch off.
- (f) Turn the power switch on (IG), and wait for at least 60 seconds.
- (g) Check the DTCs (see page 05-1402).

OK:

DTC B1900 is not output.

HINT:

Codes other than code B1900 may be output at this time, but they are not related to this check.

NG

**REPLACE AIR BAG ECU ASSY
(SEE PAGE 60-54)**

OK

4 CHECK FRONT SEAT OUTER BELT ASSY LH(P/T SQUIB (D SEAT SIDE))

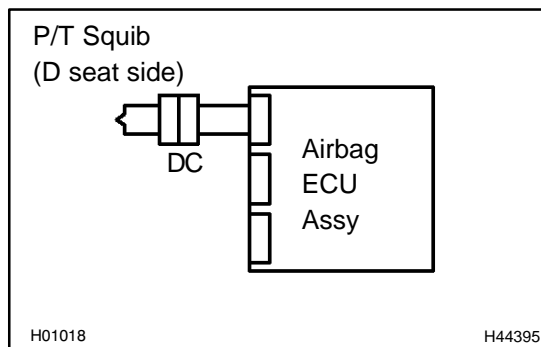

- (a) Turn the power switch off.
- (b) Disconnect the negative (-) terminal cable from the battery, and wait for at least 90 seconds.
- (c) Connect the connector to the front seat outer belt assy LH.
- (d) Connect the negative (-) terminal cable to the battery, and wait for at least 2 seconds.
- (e) Turn the power switch on (IG), and wait for at least 60 seconds.
- (f) Clear the DTCs stored in memory (see page 05-1402).
- (g) Turn the power switch off.
- (h) Turn the power switch on (IG), and wait for at least 60 seconds.
- (i) Check the DTCs (see page 05-1402).

OK:

DTC B1900 is not output.

HINT:

Codes other than code B1900 may be output at this time, but they are not related to this check.

NG

**REPLACE FRONT SEAT OUTER BELT ASSY LH
(SEE PAGE 61-9)**

OK

USE SIMULATION METHOD TO CHECK (SEE PAGE 05-1397)

HINT:

- Perform the simulation method by selecting the check mode with the hand-held tester (see page 05-1405).
- After selecting the check mode, perform the simulation method by wiggling each connector of the air-bag system or driving the vehicle on a city or rough road (see page 05-1405).