

DTC	B1620/21	SIDE AIRBAG SENSOR ASSEMBLY (D SEAT SIDE) MALFUNCTION
------------	-----------------	--

CIRCUIT DESCRIPTION

The side airbag sensor assembly (D seat side) consists of the safing sensor, the diagnostic circuit, the lateral deceleration sensor, etc.

If the airbag ECU Assy receives signals from the lateral deceleration sensor, it determines whether or not the SRS should be activated.

DTC B1620 is recorded when a malfunction is detected in the side airbag sensor assembly (D seat side) circuit.

DTC No.	DTC Detecting Condition	Trouble Area
B1620	<ul style="list-style-type: none"> • When the Airbag ECU Assy receives a line short signal, open signal, short to ground signal or B+ short signal in the side airbag sensor assembly (D seat side) circuit for 2 seconds. • Side airbag sensor Assy LH malfunction • Airbag ECU Assy malfunction 	<ul style="list-style-type: none"> • Floor wire • Side airbag sensor Assy LH • Airbag ECU Assy

WIRING DIAGRAM

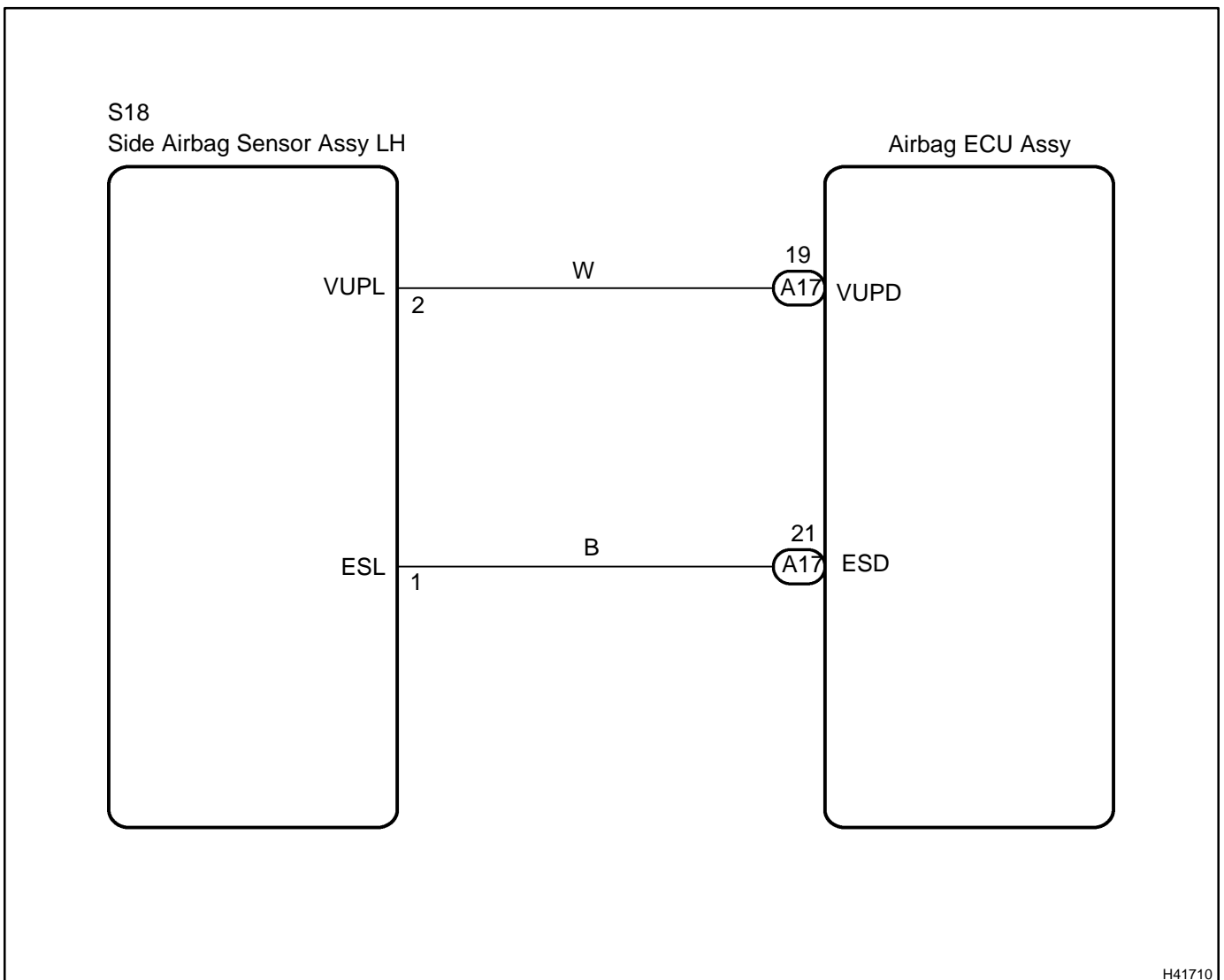

H41710

INSPECTION PROCEDURE

CAUTION:

Be sure to perform the following procedures before troubleshooting to avoid unexpected airbag deployment.

- (a) Turn the power switch off.
- (b) Disconnect the negative (–) terminal cable from the battery, and wait for at least 90 seconds.
- (c) Disconnect the connectors from the airbag ECU Assy.
- (d) Disconnect the connectors from the horn button Assy.
- (e) Disconnect the connectors from the front passenger airbag Assy.
- (f) Disconnect the connector from the front seat airbag Assy LH.
- (g) Disconnect the connector from the front seat airbag Assy RH.
- (h) Disconnect the connector from the curtain shield airbag Assy LH.
- (i) Disconnect the connector from the curtain shield airbag Assy RH.
- (j) Disconnect the connector from the front seat outer belt Assy LH.
- (k) Disconnect the connector from the front seat outer belt Assy RH.

1 CHECK DTC

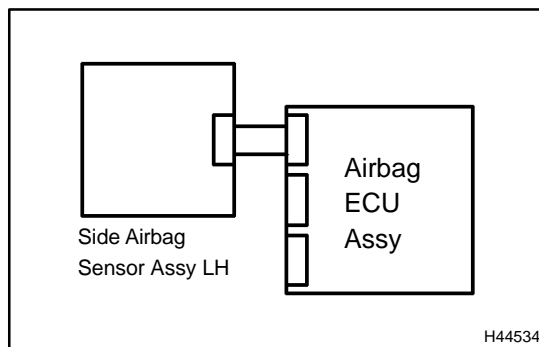

- (a) Connect the connectors to the airbag ECU Assy.
- (b) Connect the negative (–) terminal cable to the battery, and wait for at least 2 seconds.
- (c) Turn the power switch is on (IG), and wait for at least 60 seconds.
- (d) Clear the DTCs stored in memory (see page 05-1402).
- (e) Turn the power switch off.
- (f) Turn the power switch on (IG), and wait for at least 60 seconds.
- (g) Check the DTCs (see page 05-1402).

OK:

DTC B1620 is not output.

HINT:

Codes other than code B1620 may be output at this time, but they are not related to this check.

NG

Go to step 2

OK

USE SIMULATION METHOD TO CHECK (SEE PAGE 05-1397)

2 CHECK CONNECTION OF CONNECTORS

- (a) Turn the power switch off.
- (b) Disconnect the negative (-) terminal cable from the battery, and wait for at least 90 seconds.
- (c) Check that the connectors are properly connected to the airbag ECU Assy and the side airbag sensor Assy LH.

OK:

The connectors are connected.

NG → **CONNECT CONNECTORS, THEN GO TO STEP 1**

OK

3 CHECK FLOOR WIRE(OPEN)

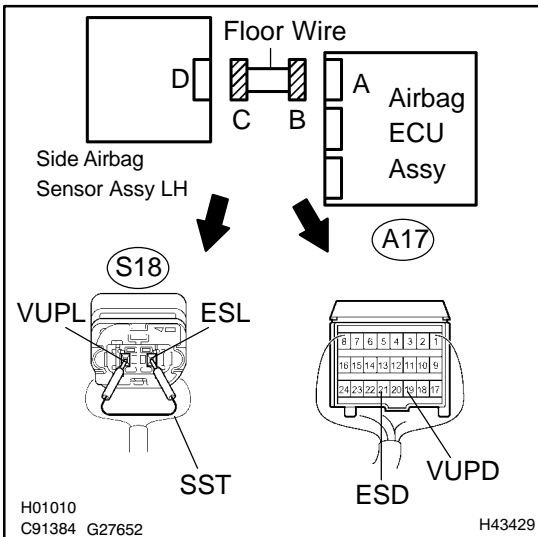

- (a) Disconnect the connectors from the airbag ECU Assy and the side airbag sensor Assy LH.
- (b) Using SST, connect S18-2 (VUPL) and S18-1 (ESL) of connector "C".
SST 09843-18040
- (c) Measure the resistance according to the value(s) in the table below.

Standard:

Tester connection	Condition	Specified condition
A17-19 (VUPD) – A17-21 (ESD)	Always	Below 1 Ω

NG → **REPAIR OR REPLACE FLOOR WIRE**

OK

4 CHECK FLOOR WIRE(SHORT)

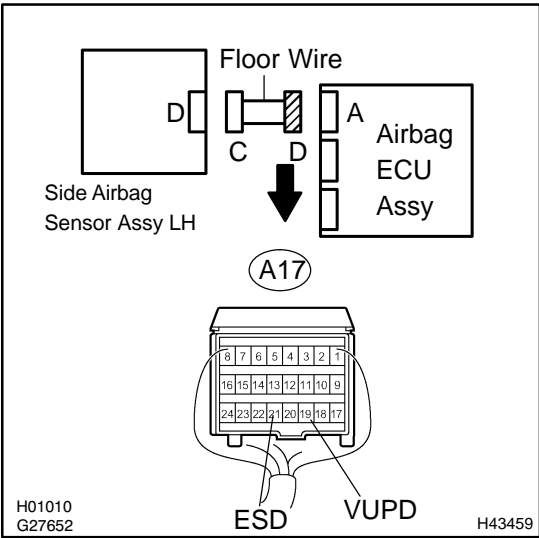

- (a) Disconnect the SST from connector "C".
- (b) Measure the resistance according to the value(s) in the table below.

Standard:

Tester connection	Condition	Specified condition
A17-19 (VUPD) - A17-21 (ESD)	Always	1 MΩ or Higher

NG REPAIR OR REPLACE FLOOR WIRE

OK

5 CHECK FLOOR WIRE(TO B+)

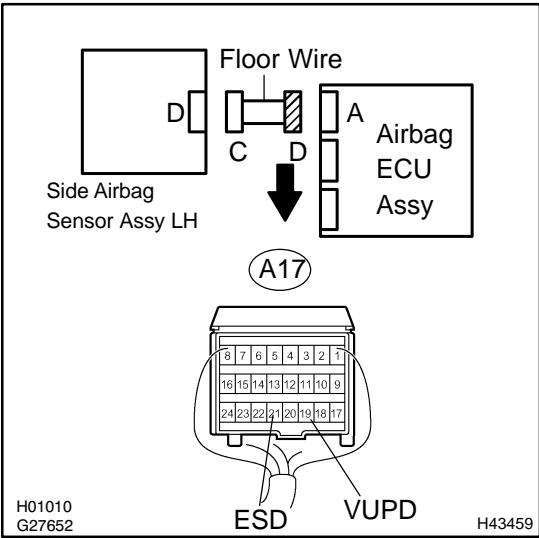

- (a) Connect the negative (-) terminal cable to the battery, and wait for at least 2 seconds.
- (b) Turn the power switch on (IG).
- (c) Measure the voltage according to the value(s) in the table below.

Standard:

Tester connection	Condition	Specified condition
A17-19 (VUPD) - Body ground	Power switch is on (IG)	Below 1 V
A17-21 (ESD) - Body ground	Power switch is on (IG)	Below 1 V

NG REPAIR OR REPLACE FLOOR WIRE

OK

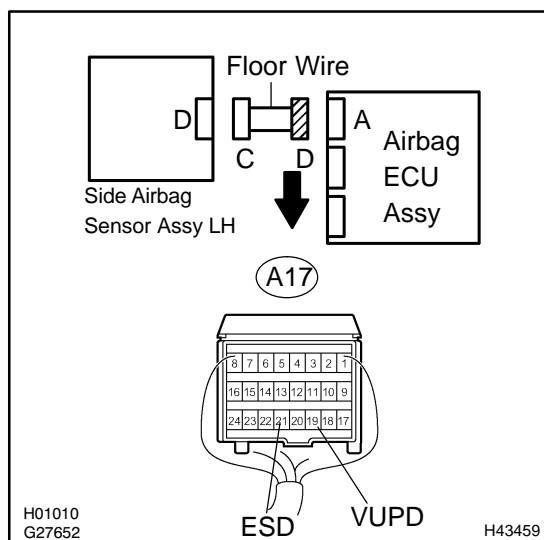
6 CHECK FLOOR WIRE(TO GROUND)

- (a) Turn the power switch off.
- (b) Disconnect the negative (-) terminal cable from the battery, and wait for at least 90 seconds.
- (c) Measure the resistance according to the value(s) in the table below.

Standard:

Tester connection	Condition	Specified condition
A17-19 (VUPD) – Body ground	Always	1 MΩ or Higher
A17-21 (ESD) – Body ground	Always	1 MΩ or Higher

NG → **REPAIR OR REPLACE FLOOR WIRE**

OK

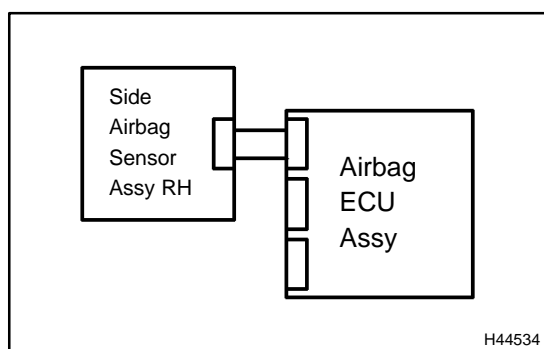
7 CHECK SIDE AIR BAG SENSOR ASSY LH

- (a) Connect the connectors to the airbag ECU Assy.
- (b) Interchange the side airbag sensor Assy LH with RH and connect the connectors to them.
- (c) Connect the negative (-) terminal cable to the battery, and wait for at least 2 seconds.
- (d) Turn the power switch on (IG), and wait for at least 60 seconds.
- (e) Clear the DTCs stored in memory (see page 05-1402).
- (f) Turn the power switch off.
- (g) Turn the power switch on (IG), and wait for at least 60 seconds.
- (h) Check the DTCs (see page 05-1402).

Result:

DTC B1620 is output.	A
DTC B1625 is output.	B
DTC B1620 or B1625 are not output.	C

A → **REPLACE AIR BAG ECU ASSY (SEE PAGE 60-54)**

B → **REPLACE SIDE AIR BAG SENSOR ASSY LH (SEE PAGE 60-58)**

C

USE SIMULATION METHOD TO CHECK (SEE PAGE 05-1397)