

# Push Button Start System and Hybrid Vehicle Immobilizer System

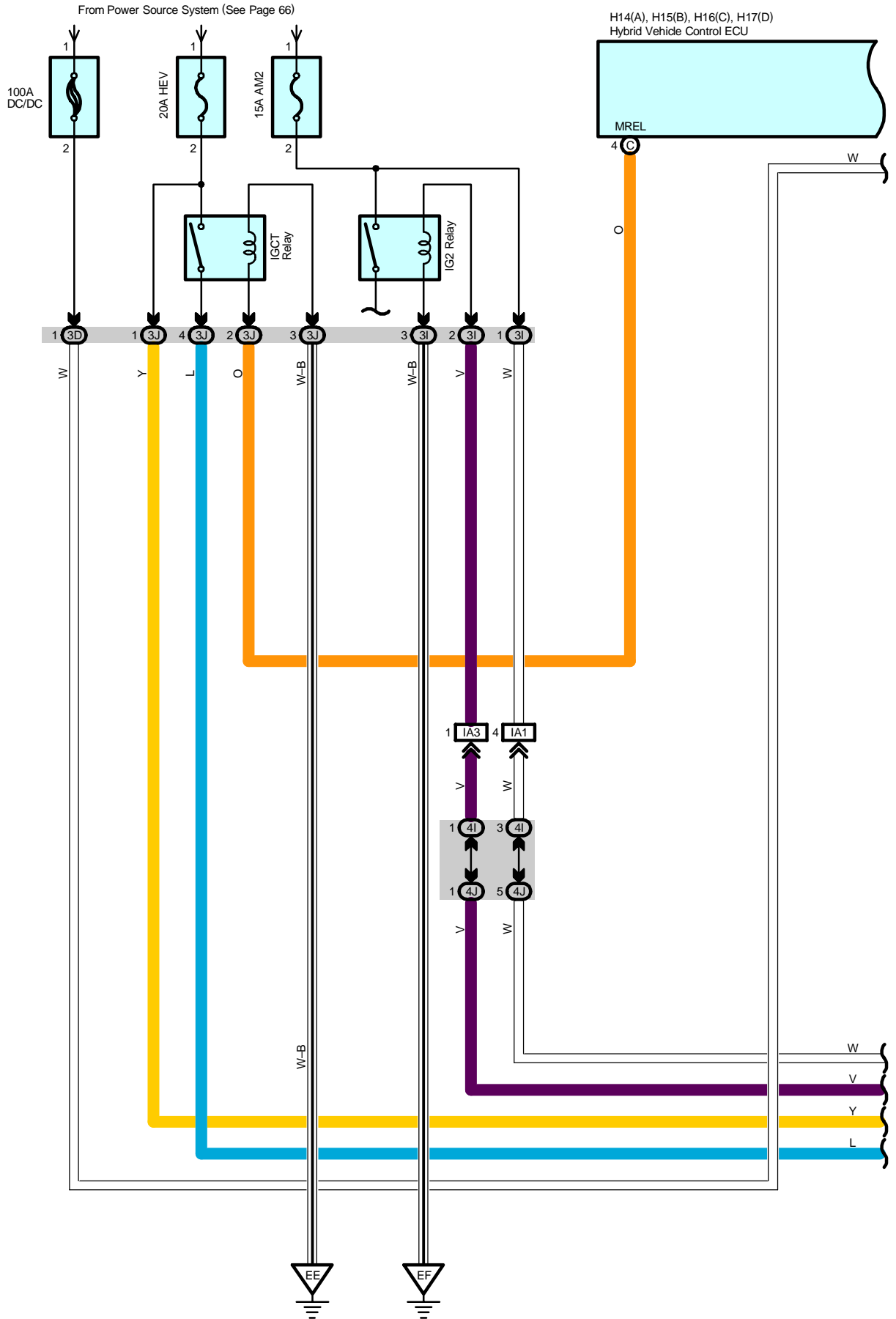

H14(A), H15(B), H16(C), H17(D)  
Hybrid Vehicle Control ECU

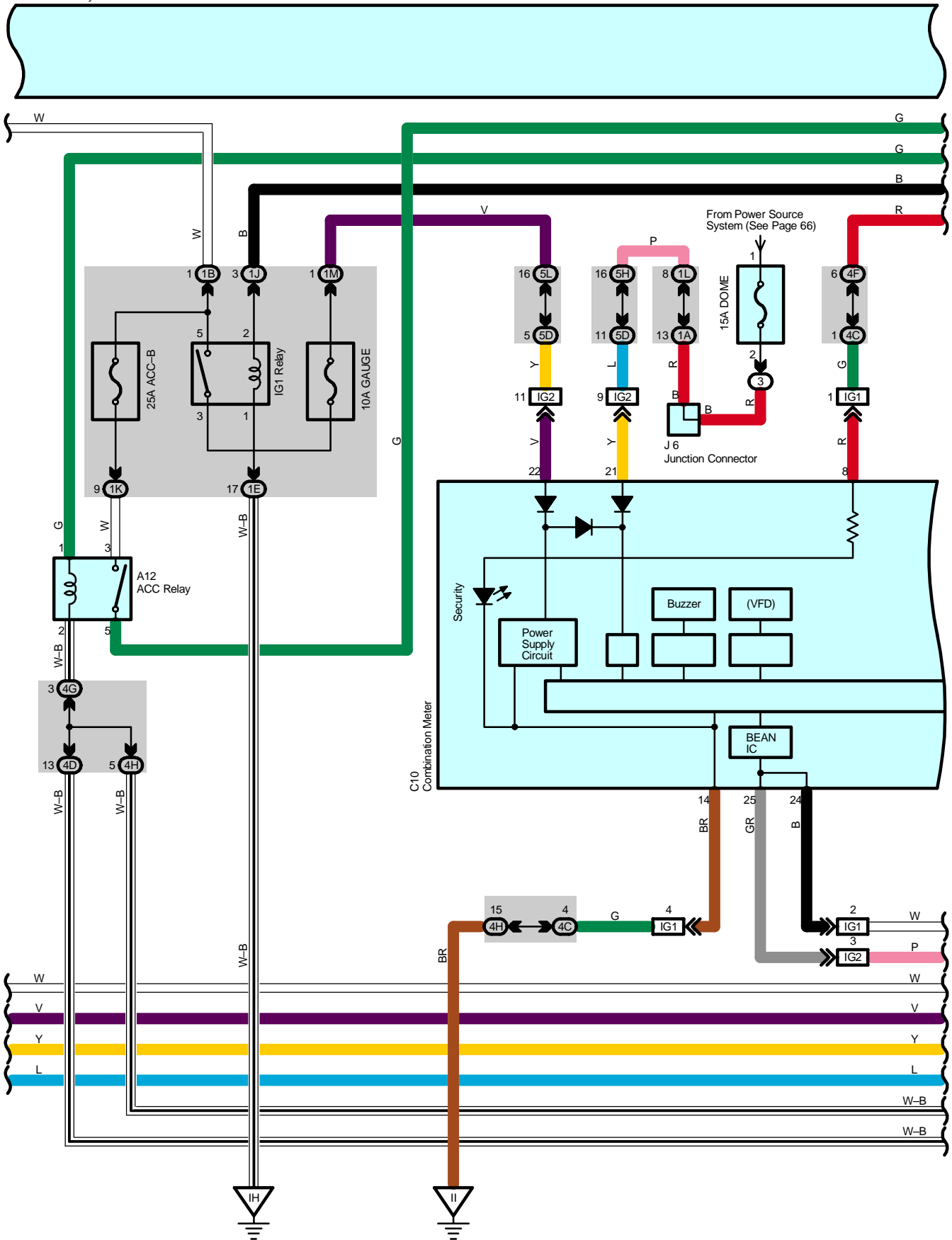

# Push Button Start System and Hybrid Vehicle Immobilizer System

H14(A), H15(B), H16(C), H17(D)  
Hybrid Vehicle Control ECU

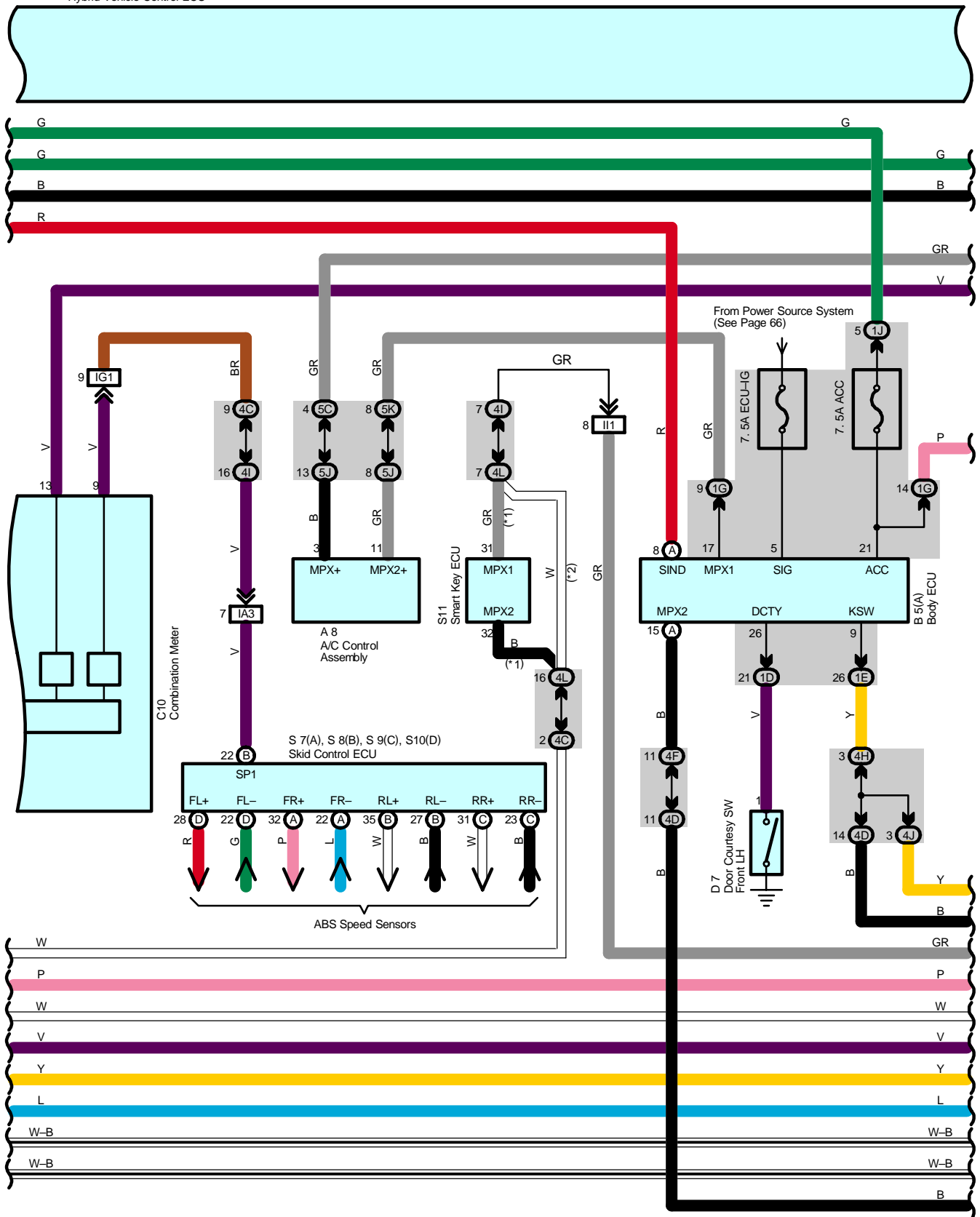

H14(A), H15(B), H16(C), H17(D)  
Hybrid Vehicle Control ECU

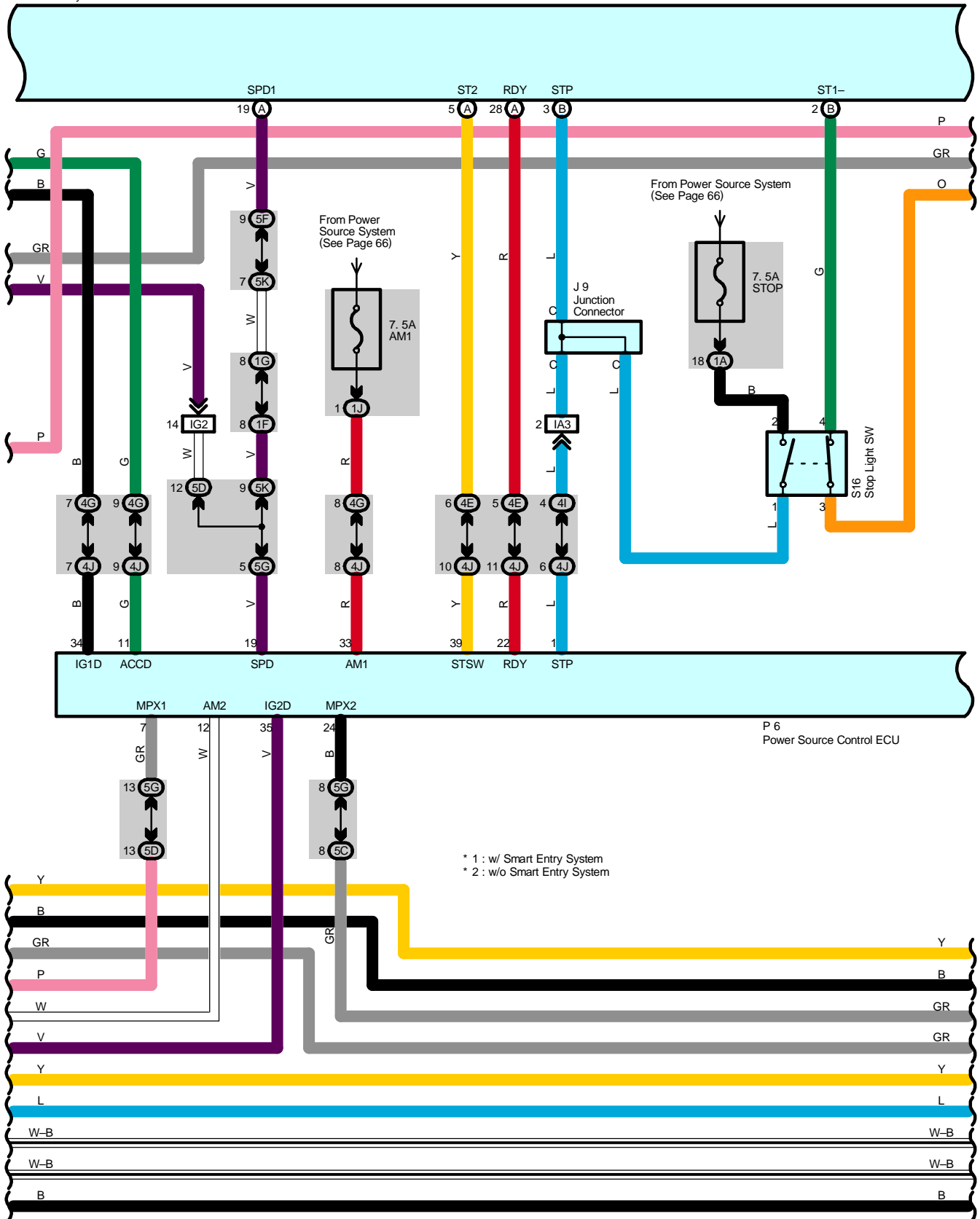

# Push Button Start System and Hybrid Vehicle Immobilizer System

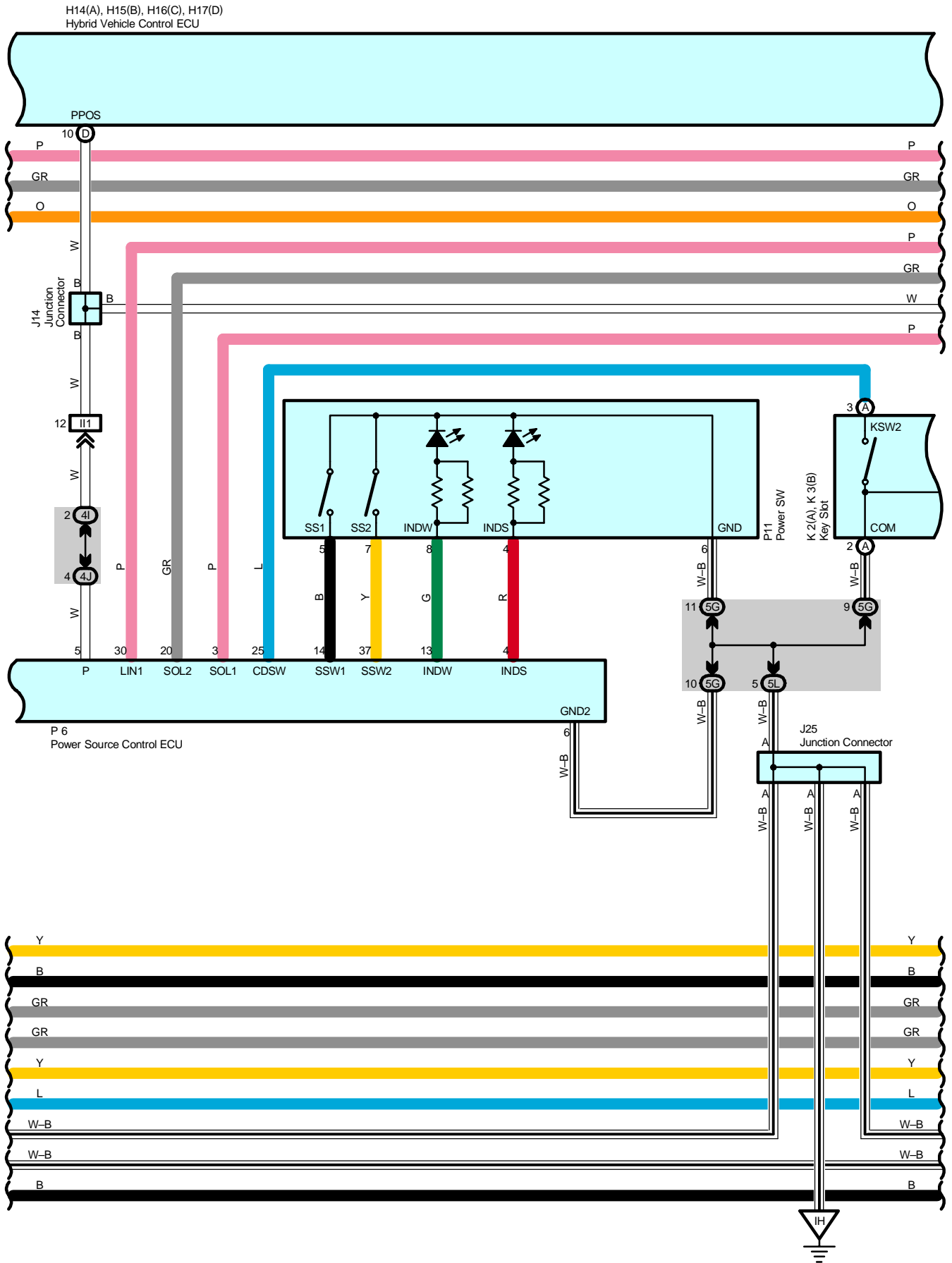

H14(A), H15(B), H16(C), H17(D)  
Hybrid Vehicle Control ECU

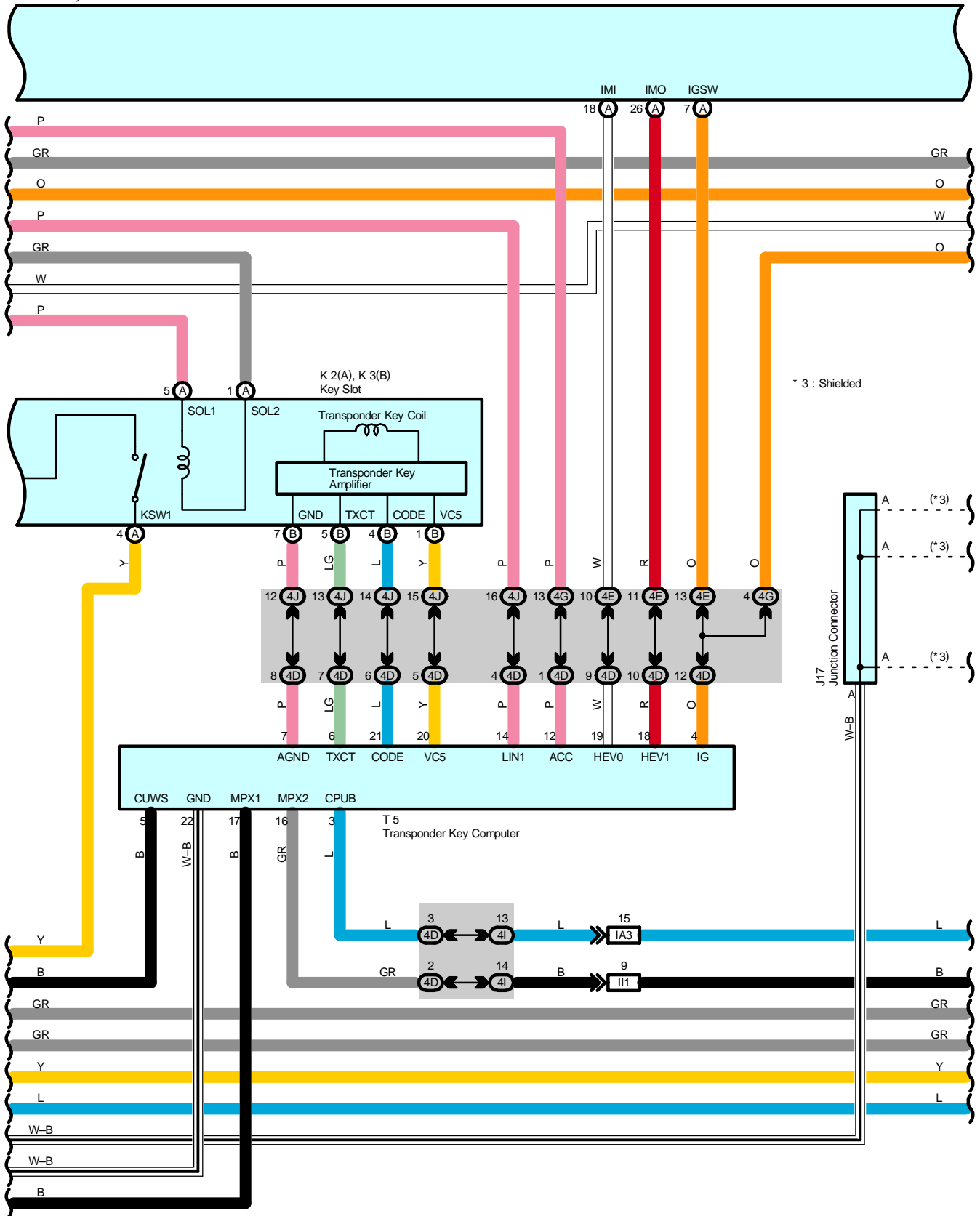

# Push Button Start System and Hybrid Vehicle Immobilizer System

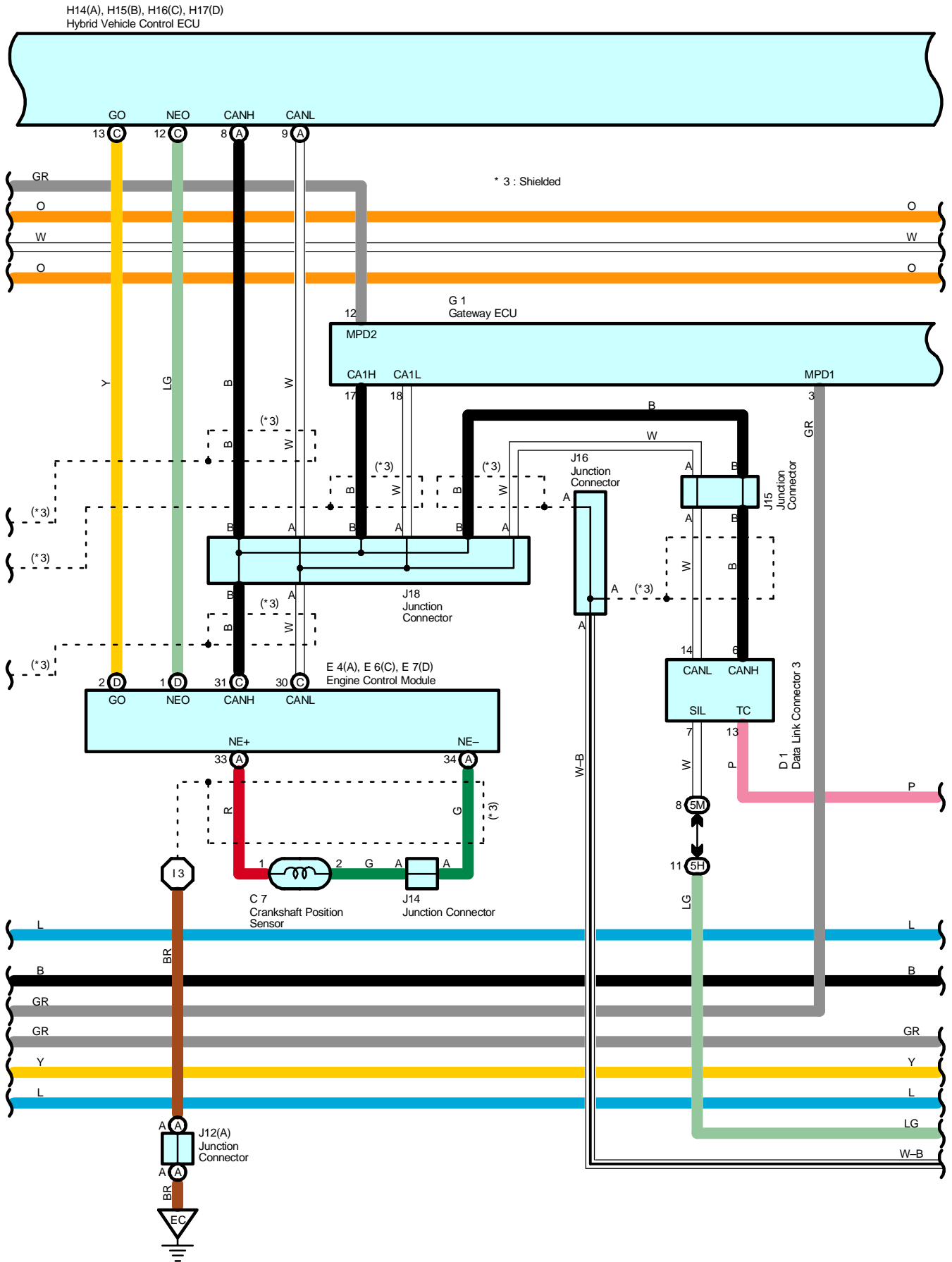

H14(A), H15(B), H16(C), H17(D)  
Hybrid Vehicle Control ECU

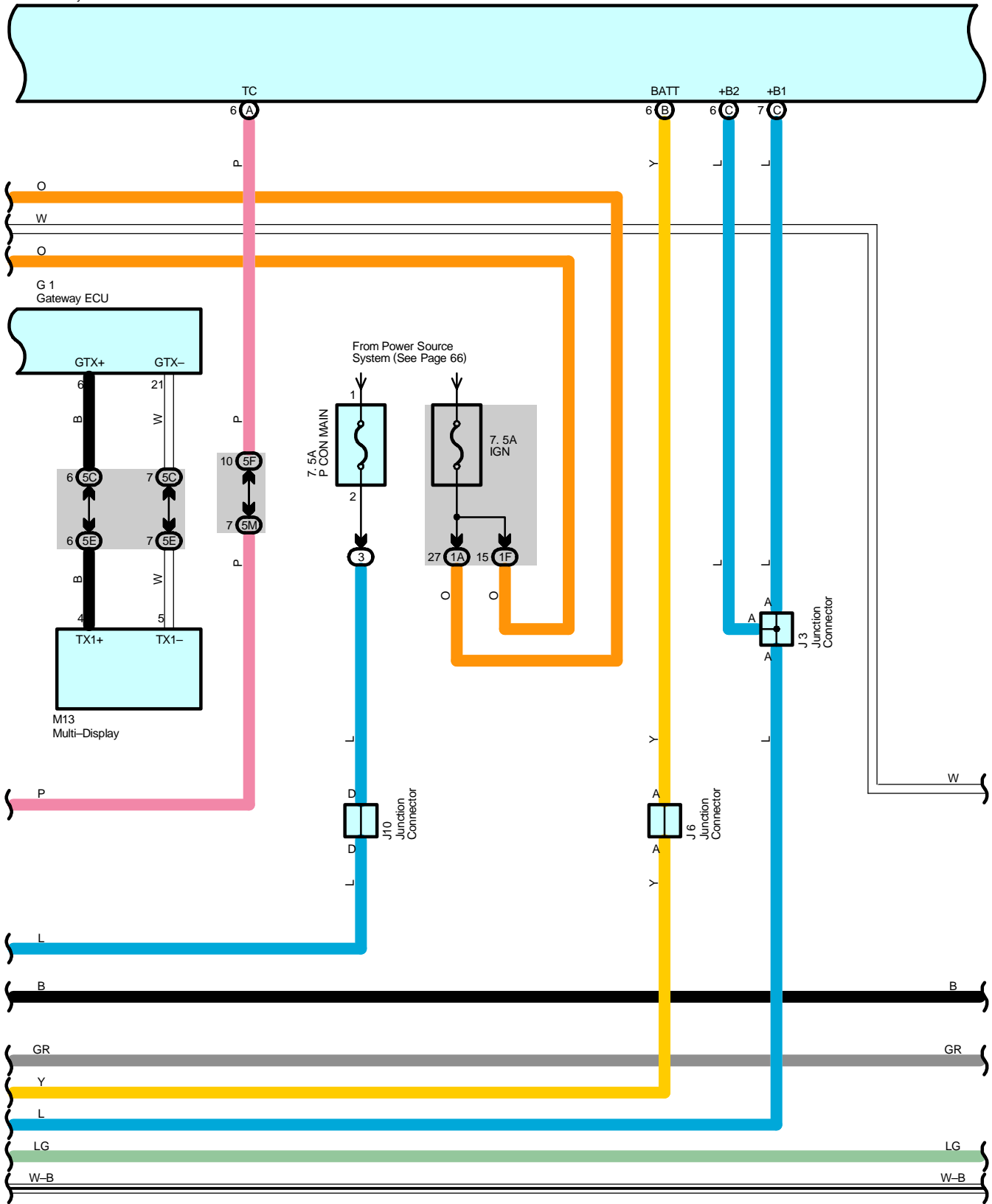



# Push Button Start System and Hybrid Vehicle Immobilizer System

H14(A), H15(B), H16(C), H17(D)  
Hybrid Vehicle Control ECU

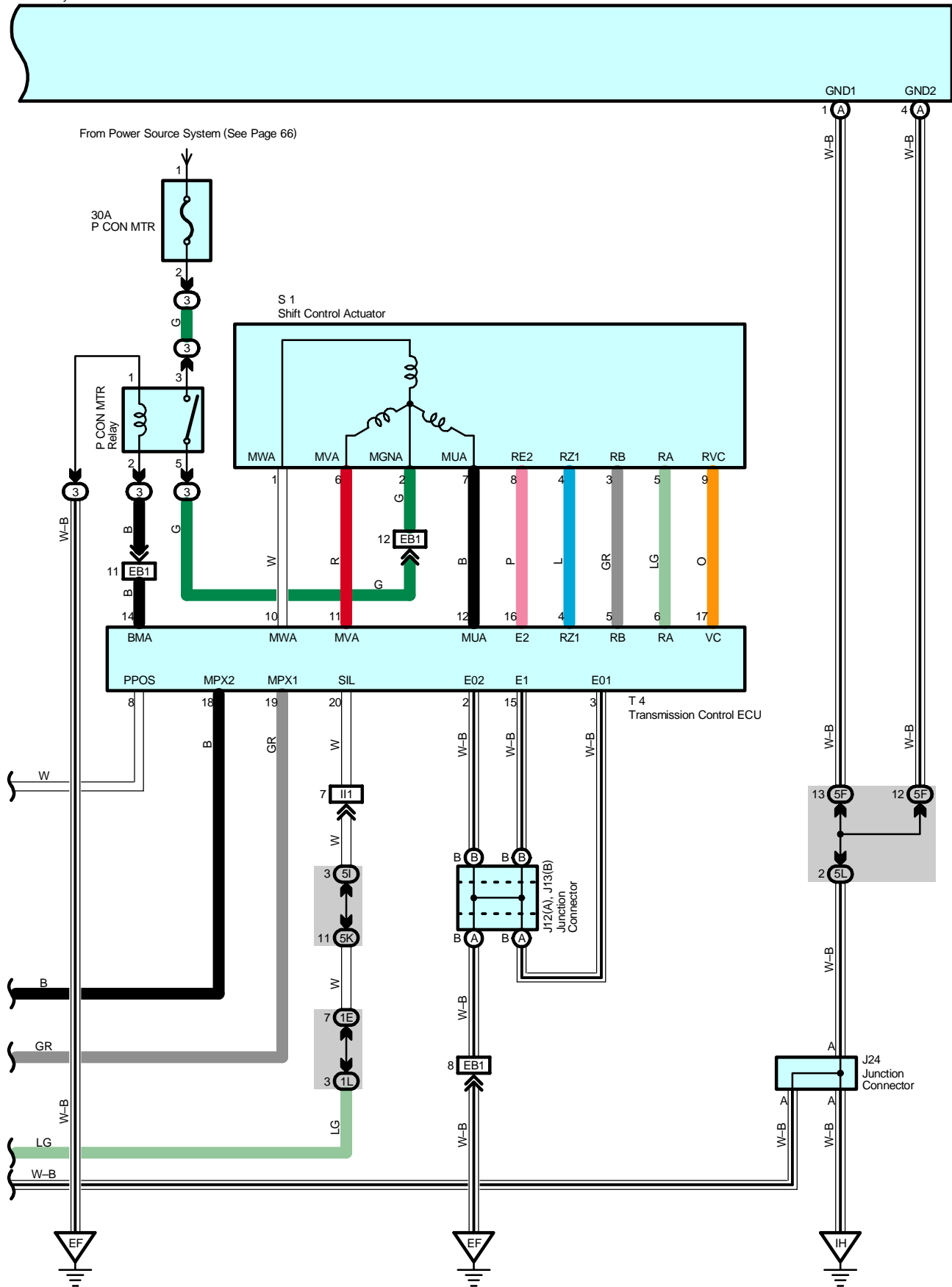

## System Outline

This is the system to change power supply mode by pushing power SW and to start hybrid system by operating power SW and brake pedal simultaneously. It also has function to hold the electrical key in the key slot and not to release the key from it unless the power supply condition and shift range position are met. If there is abnormality in the system, amber portion of power SW blinks to warn the driver.

### 1. ACC ON Operation

When the electrical key turns on half-inserted SW and deep-inserted SW after inserting in the key slot, transponder key computer activates transponder key amplifier incorporated in key slot to identify ID. After the identification, if power SW is pushed without depressing brake pedal, power source control ECU starts. The ECU confirms that the brake pedal is not depressed from signal of stop light SW and also requests transponder key computer for ID identification result. If the ID identification is normal, power source control ECU turns on ACC relay and changes indicator of power SW to green lighting. In consequence, power supply is set to ACC ON condition.

### 2. IG ON Operation

If power SW is pushed without depressing brake pedal when ACC ON, power source control ECU confirms that the brake pedal is not depressed, and then turns on IG1 relay and IG2 relay as well as change indicator of power SW to amber lighting. Power supply is IG ON condition then.

### 3. Hybrid Start-Up Operation (READY)

When the electrical key turns on half-inserted SW and deep-inserted SW after inserting in the key slot, transponder key computer activates transponder key amplifier incorporated in key slot to identify ID. After the identification, if power SW is pushed with depressing brake pedal, power source control ECU starts. The ECU confirms that the brake pedal is depressed from signal of stop light SW and also requests transponder key computer for ID identification result. If the ID identification is normal, the ECU turns on ACC relay, IG1 relay and IG2 relay, and changes indicator of power SW to amber lighting. Power supply is IG ON condition then.

After that, power source control ECU sends start-up signal to hybrid vehicle control ECU. Hybrid vehicle control ECU and transponder key computer make communication for start-up permission. Hybrid vehicle control ECU controls to start-up hybrid system (READY).

At starting up hybrid system, power source control ECU controls to light off indicator of power SW.

### 4. Power Supply Off Operation

\* When shift range is in P range

If power SW is pushed with power supply at READY condition while the vehicle is stationary, power source control ECU confirms that shift range is in P range, and then turns off ACC relay, IG1 relay and IG2 relay to put power supply in OFF condition. The ECU also controls to light off indicator of power SW.

If power SW is pushed with power supply at IG ON condition and without depressing brake pedal while the vehicle is stationary, power source control ECU confirms that shift range is in P range, and then turns off ACC relay, IG1 relay and IG2 relay to put power supply in OFF condition. The ECU also controls to light off indicator of power SW.

If electrical key is taken off from key slot with power supply at ACC ON condition while the vehicle is stationary, power source control ECU controls to put power supply in OFF condition automatically, which lights off indicator of power SW.

\* When shift range is in other than P range

If power SW is pushed with power supply at IG ON (Including READY) condition while the vehicle is stationary, parking lock operation is carried out. After that, power source control ECU confirms that shift range is in P range and then turns off ACC relay, IG1 relay and IG2 relay to put power supply in OFF condition. The ECU controls to light off indicator of power SW.

### 5. Key Interlock Operation

Power source control ECU controls to hold the electrical key in the key slot and not to release the key from it unless the power supply condition and shift range position are met. Power supply condition and shift range position during the key interlock in operation are as follows;

\* At starting-up hybrid system

\* At power supply at IG ON

\* At power supply at ACC ON and shift range at other than P range

### 6. Emergency Stop Operation of Hybrid System

If power SW is kept pushed more than three seconds during driving, hybrid system stops and power supply is changed to ACC ON.

### 7. Power Supply Resuming Control

Power source control ECU always stores power supply condition (OFF, ACC ON, IG ON)

When power supply is resumed after shutting off power supply by disconnecting battery terminal, original power supply condition returns due to control of power source control ECU.

# Push Button Start System and Hybrid Vehicle Immobilizer System

## Service Hints

### P6 Power Source Control ECU

12, 33–Ground : Always approx. 12 volts

34, 35–Ground : Approx. 12 volts with the power SW at IG ON position

11–Ground : Approx. 12 volts with the power SW at ACC ON or IG ON position

6–Ground : Always continuity

1–Ground : Approx. 12 volts with the brake pedal depressed

## ○ : Parts Location

Code	See Page	Code	See Page	Code	See Page
A8	46	H17   D	47	K2   A	48
A12	46	J3	45	K3   B	48
B5   A	46	J6	48	M13	48
C7	44	J9	48	P6	49
C10	47	J10	48	P11	49
D1	47	J12   A	48	S1	45
D7	50	J13   B	48	S7   A	49
E4   A	47	J14	48	S8   B	49
E6   C	47	J15	48	S9   C	49
E7   D	47	J16	48	S10   D	49
G1	47	J17	48	S11	49
H14   A	47	J18	48	S16	49
H15   B	47	J24	48	T4	49
H16   C	47	J25	48	T5	49

## ○ : Relay Blocks

Code	See Page	Relay Blocks (Relay Block Location)
3	22	Engine Room R/B (Engine Compartment Left)

 : **Junction Block and Wire Harness Connector**

Code	See Page	Junction Block and Wire Harness (Connector Location)
1A	28	Engine Room Main Wire and Driver Side J/B (Lower Finish Panel)
1B		
1D		
1E	28	Instrument Panel Wire and Driver Side J/B (Lower Finish Panel)
1F		
1G		
1J		
1K		
1L		
1M		
3D	22	Engine Room Main Wire and Engine Room J/B (Engine Compartment Left)
3I		
3J		
4C	36	Instrument Panel Wire and Center Connector No.1 (Behind the Combination Meter)
4D		
4E		
4F		
4G		
4H		
4I		
4J		
4L		
5C	40	Instrument Panel Wire and Center Connector No.2 (Instrument Panel Brace RH)
5D		
5E		
5F		
5G		
5H		
5I		
5J		
5K		
5L		
5M		

 : **Connector Joining Wire Harness and Wire Harness**

Code	See Page	Joining Wire Harness and Wire Harness (Connector Location)
EB1	54	Engine Wire and Engine Room Main Wire (Inside of the Engine Room R/B)
IA1	56	Engine Room Main Wire and Instrument Panel Wire (Upper Parts of Front Body Pillar LH)
IA3		
IG1	58	Instrument Panel Wire and Instrument Panel No.2 Wire (Behind the Combination Meter)
IG2		
II1	58	Engine Wire and Instrument Panel Wire (Behind the Glove Box)

 : **Ground Points**

Code	See Page	Ground Points Location
EC	54	Engine Block
EE	54	Left Side of the Suspension Tower
EF		
IH	56	Cowl Side Panel LH
II	56	Instrument Panel Brace LH

# Push Button Start System and Hybrid Vehicle Immobilizer System

---



: Splice Points

Code	See Page	Wire Harness with Splice Points	Code	See Page	Wire Harness with Splice Points
I3	<a href="#">58</a>	Engine Wire			

