

■ CONSTRUCTION OF MAIN COMPONENTS

1. MG1 and MG2

General

- Both the MG1 (Motor Generator No. 1) and the MG2 (Motor Generator No. 2) are compact, lightweight, and highly efficient alternating current permanent magnet synchronous type.
- Serving as the source of supplemental motive force that provides power assistance to the engine as needed, the electric motor helps the vehicle achieve excellent dynamic performance, including smooth start-offs and acceleration. When the regenerative brake is activated, MG2 converts the vehicle's kinetic energy into electrical energy, which is then stored in the HV battery.
- MG1 recharges the HV battery and supplies electrical power to drive MG2. In addition, by regulating the amount of electrical power generated (thus varying the generator's rpm), MG1 effectively controls the continuously variable transmission function of the transaxle. MG1 also serves as the starter to start the engine.
- A cooling system via water pump for the MG1 and MG2 has been added. For details, refer to cooling system (for Inverter, MG1 and MG2) on page TH-34.

— Main Changes from '03 Prius —

- Accompanied by enhancing the rotor robustness of MG1, its rpm range for the maximum possible output has been increased from 6,500 to 10,000 rpm, therefore the charging capability has been enhanced.
- Structure of each built-in permanent magnet inside the rotor of MG2 has been optimized by redesigning it to V shaped structure, and improvement of its power output and torque has been realized.
- For MG2 control, a newly developed over-modulation control system has been adopted to the medium-speed range.

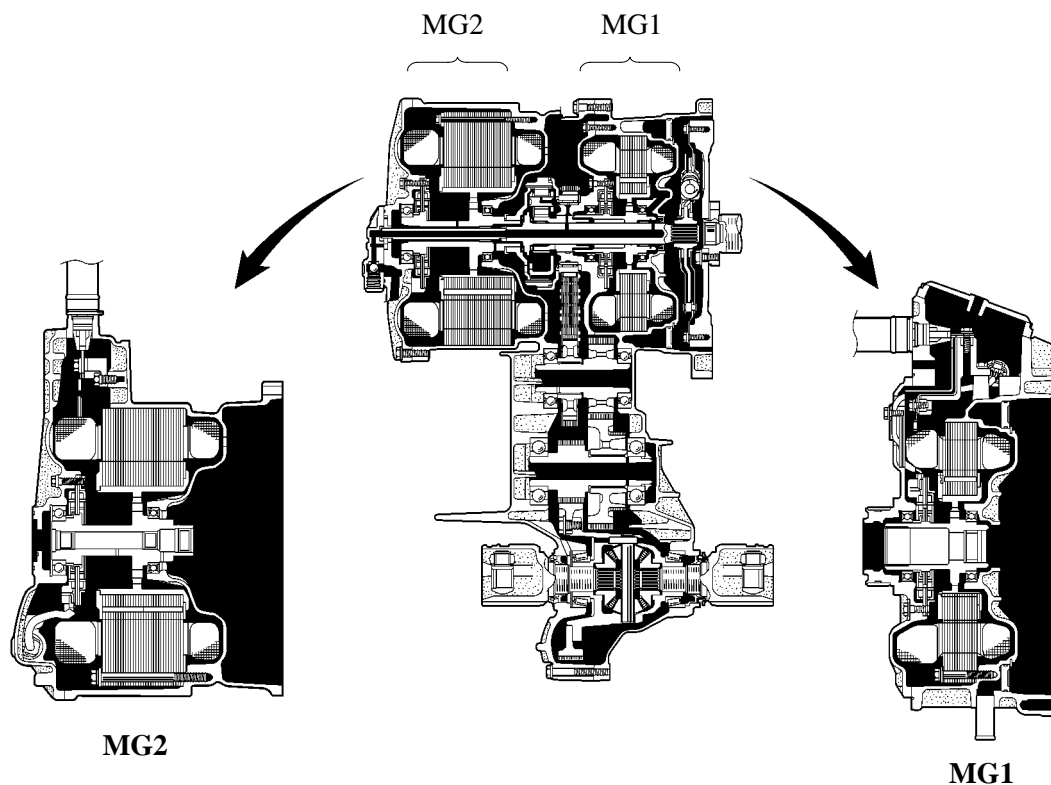

► MG1 Specifications ◀

Item	'04 Model	'03 Model
Type	Permanent Magnet Motor	←
Function	Generate, Engine Starter	←
Maximum Voltage [V]	AC 500	AC 273.6
Cooling system	Water-cooled	←

► MG2 Specifications ◀

Item	'04 Model	'03 Model
Type	Permanent Magnet Motor	←
Function	Generate, Drive Wheels	←
Maximum Voltage [V]	AC 500	AC 273.6
Maximum Output kW (PS) / rpm	50 (68) / 1,200 ~ 1,540	33 (45) / 1,040 ~ 5,600
Maximum Torque N·m (kgf·m) / rpm	400 (40.8) / 0 ~ 1,200	350 (35.7) / 0 ~ 400
Cooling system	Water-cooled	←

► System Diagram ◀

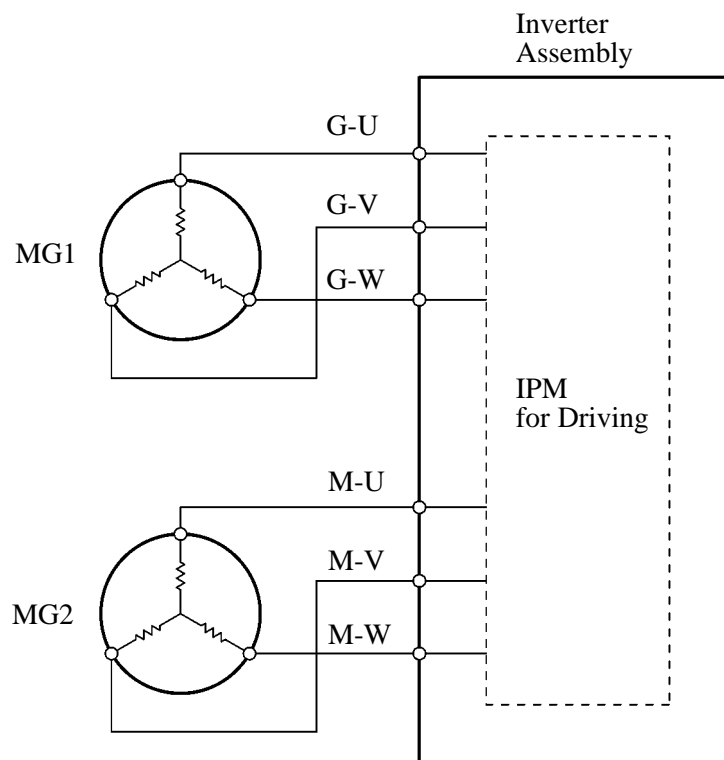

Permanent Magnet Motor

- When a three-phase alternating current is passed through the three-phase windings of the stator coil, a rotational magnetic field is created in the electric motor. By controlling this rotating magnetic field according to the rotor's rotational position and speed, the permanent magnets that are provided in the rotor become attracted by the rotating magnetic field, thus generating torque.

The generated torque is for all practical purposes proportionate to the amount of current, and the rotational speed is controlled by the frequency of the alternating current.

Furthermore, a high level of torque, all the way to high speeds, can be generated efficiently by properly controlling the rotating magnetic field and the angles of the rotor magnets.

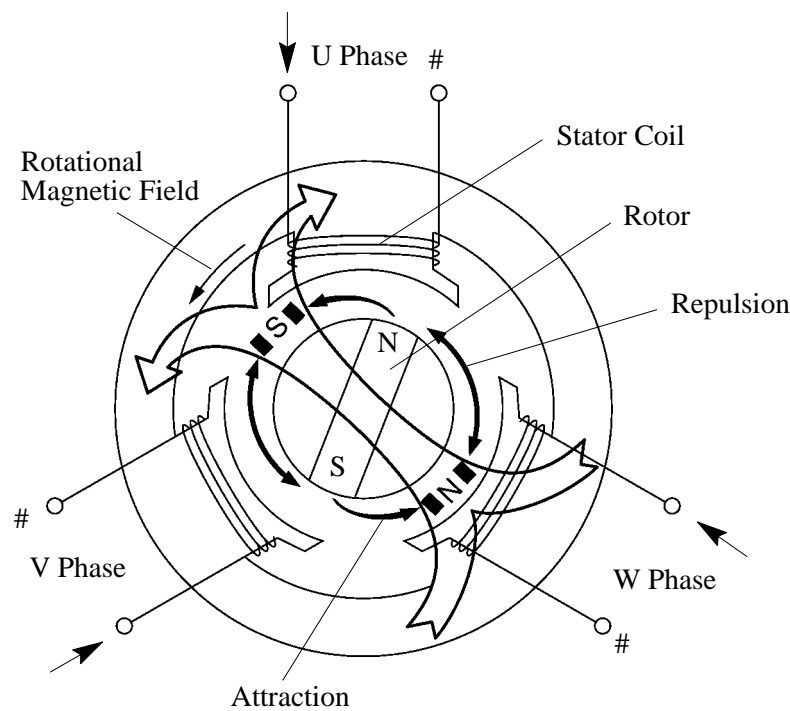

182TH29

- On '04 Prius, structure of each built-in permanent magnet inside the rotor of MG2 has been optimized by redesigning it to V-shaped structure to improve both power output and torque of the rotor. By power output, it has been improved by approximately 50 % more power as the one of '03 Prius.

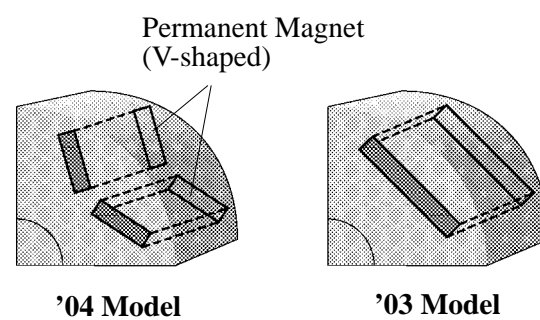

255TH90

- For MG2 control, a newly developed over-modulation control system has been adopted to the medium-speed range, in addition to the existing low- and high-speed control methods. By improving the pulse width modification method, the output in the medium-speed range has been increased by a maximum of approximately 30 %.

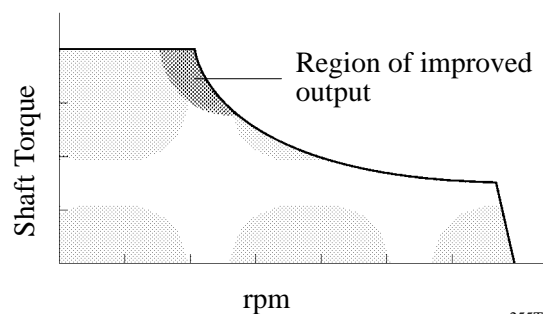

255TH91

Speed Sensor / Resolver

This is an extremely reliable and compact sensor that precisely detects the magnetic pole position, which is indispensable for ensuring the efficient control of MG1 and MG2.

The sensor's stator contains 3 coils as illustrated, and output coils B and C are electrically staggered 90 degrees. Because the rotor is oval, the distance of the gap between the stator and the rotor varies with the rotation of the rotor. Thus, by passing an alternating current through coil A, output that corresponds to the sensor rotor's position is generated by coil B and C. The absolute position can then be detected from the difference between these outputs.

In addition, the amount of positional variance within a predetermined time is calculated by the HV ECU, thus enabling this sensor to be used as an rpm sensor.

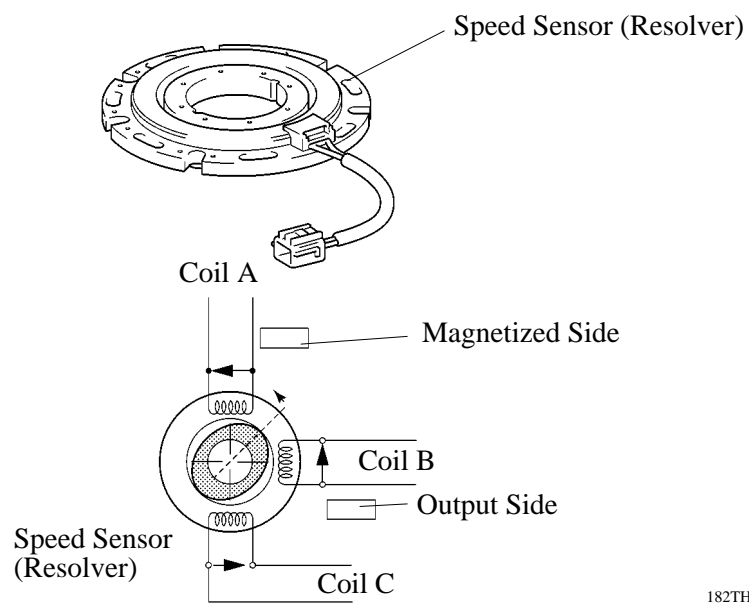

182TH09

2. Inverter Assembly

General

- The inverter converts the high-voltage direct current of the HV battery into three-phase alternating current for driving MG1 and MG2.
- The activation of the power transistors is controlled by the HV ECU. In addition, the inverter transmits information that is needed for current control, such as the output amperage or voltage, to the HV ECU.
- Together with MG1 and MG2, the inverter is cooled by the dedicated radiator of the coolant system that is separate from that of the engine.
- In the event of a collision involving the vehicle, the circuit breaker sensor, which is installed in the inverter, detects a collision signal in order to stop the system. For details, refer to During Collision Control on page TH-56.

— Main Changes from '03 Prius —

- A boost converter has been adopted in the inverter assembly, in order to boost the nominal voltage output by the HV battery from DC 201.6 V to maximum voltage of DC 500 V. After the voltage is boosted, the inverter converts the direct current into an alternating current.
- The bridge circuits for MG1 and MG2 (each consisting of 6 power transistors), and the signal processor/protective function processor have been integrated into a compact IPM (Intelligent Power Module) for driving the vehicle.
- An A/C inverter that supplies power to drive an electric inverter compressor for the A/C system has been included in the inverter assembly.
- A radiator that integrates an inverter radiator and engine radiator has been adopted to optimize the space it occupies.

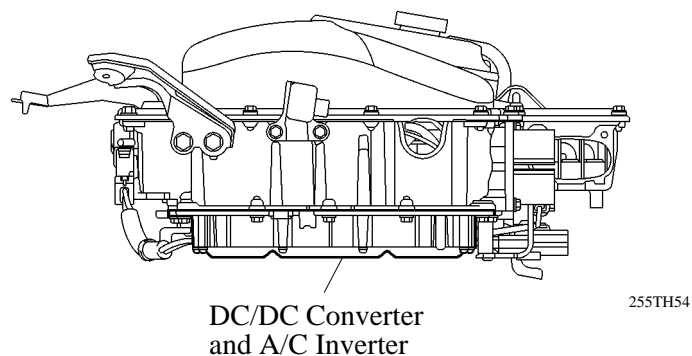
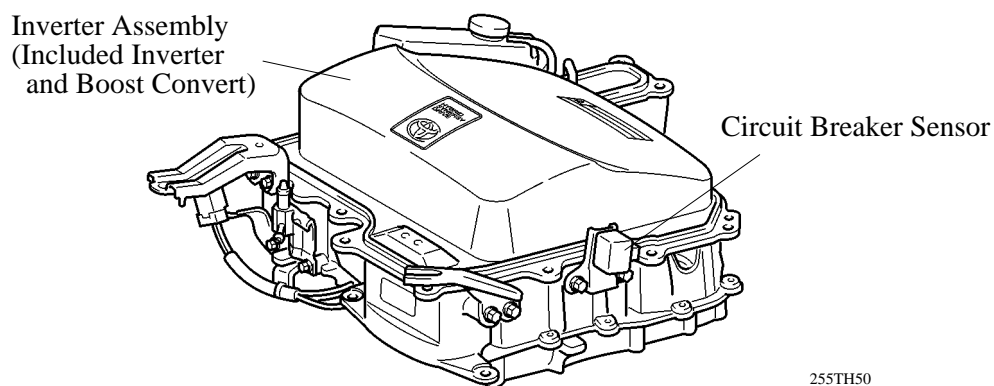

► System Diagram ◀

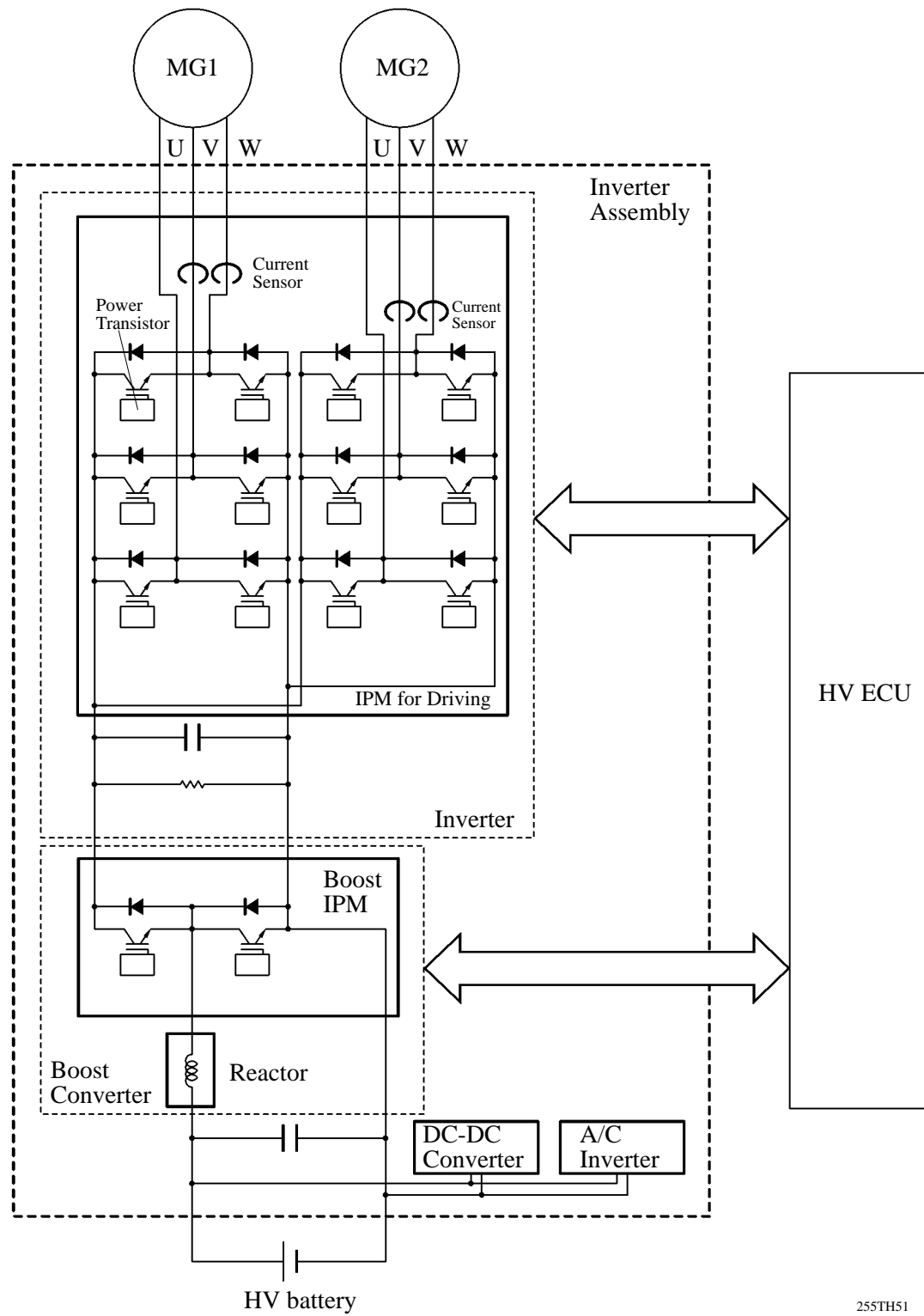

Boost Converter

- This boost converter boosts the nominal voltage of DC 201.6 V that is output by the HV battery to the maximum voltage of DC 500 V. The converter consists of the boost IPM (Integrated Power Module) with a built-in IGBT (Insulated Gate Bipolar Transistor) which performs the switching control, and the reactor which stores energy. By using these components, the converter boosts the voltage.
- When MG1 or MG2 acts as the generator, the inverter converts the alternating current (range of 201.6 to 500 V) generated by either of them into the direct current, and then the boost converter drops it to DC 201.6 V, thus the HV battery is charged.

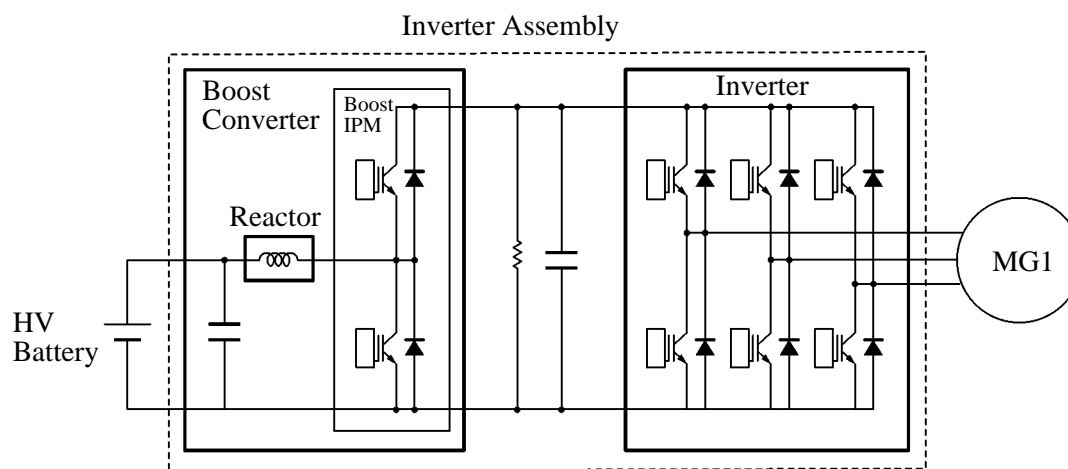
► System Diagram ◀

DC/DC Converter

The power source for auxiliary equipment of the vehicle such as the lights, audio system, and the air conditioning system (except A/C compressor), as well as the ECUs, is based on a DC 12 V system. Because the THS-II generator outputs at nominal voltage of DC 201.6 V, the converter is used to transform the voltage from DC 201.6 V to DC 12 V in order to recharge the auxiliary battery. The converter is installed on the underside of the inverter.

► **System Diagram** ◀

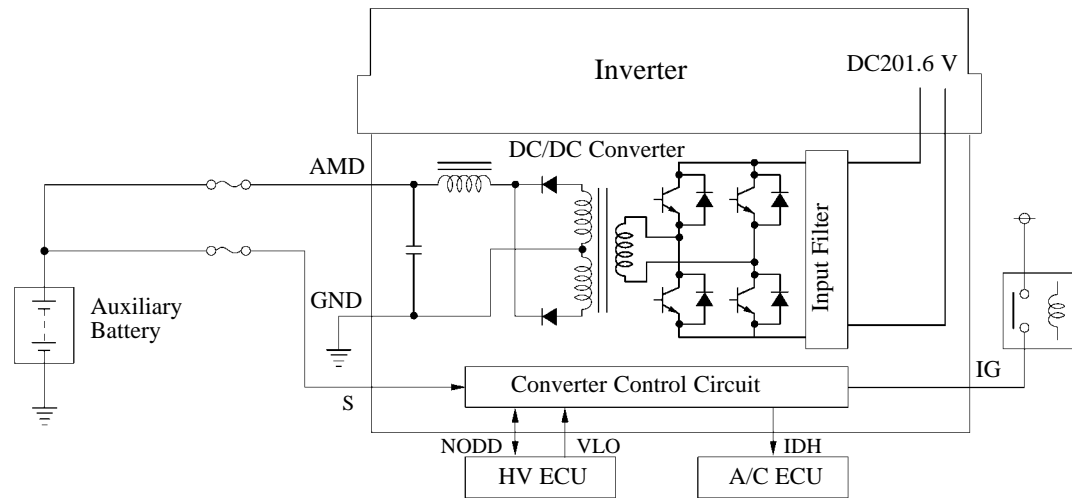

255TH92

A/C Inverter

An A/C inverter, which supplies power for driving the electric inverter compressor of the A/C system, has been included in the inverter assembly.

This inverter converts the HV battery's nominal voltage of DC 201.6 V into AC 201.6 V and supplies power to operate the compressor of the A/C system.

► **System Diagram** ◀

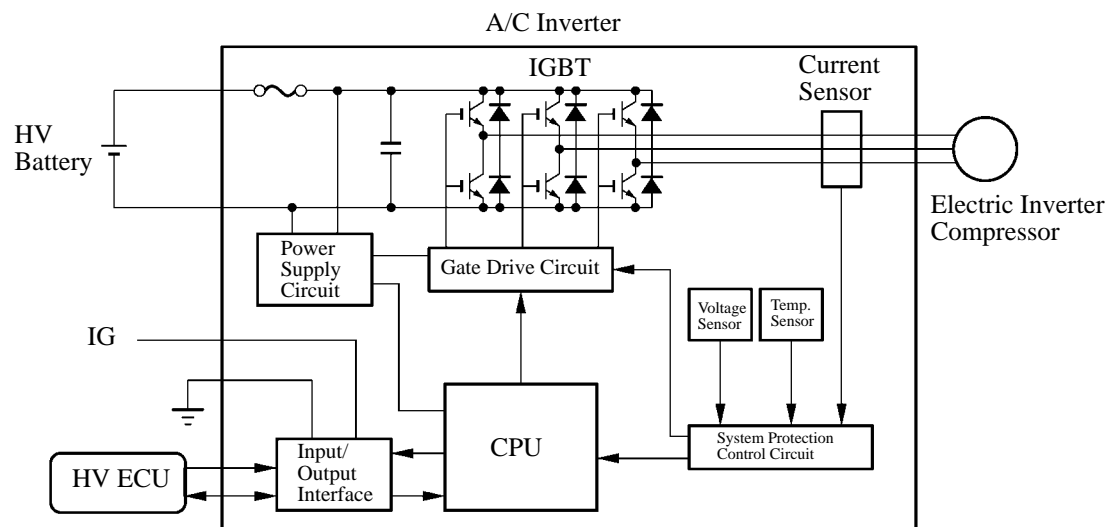

255TH93

3. Cooling System (for Inverter, MG1 and MG2)

- A cooling system via water pump for the inverter, MG1 and MG2 has been adopted. It is separated with the engine cooling system.
- This cooling system activates when the power supply status is switched to IG.
- The radiator for the cooling system is integrated with the radiator for the engine. Accordingly, the radiator has been simplified and the space it occupies has been optimized.

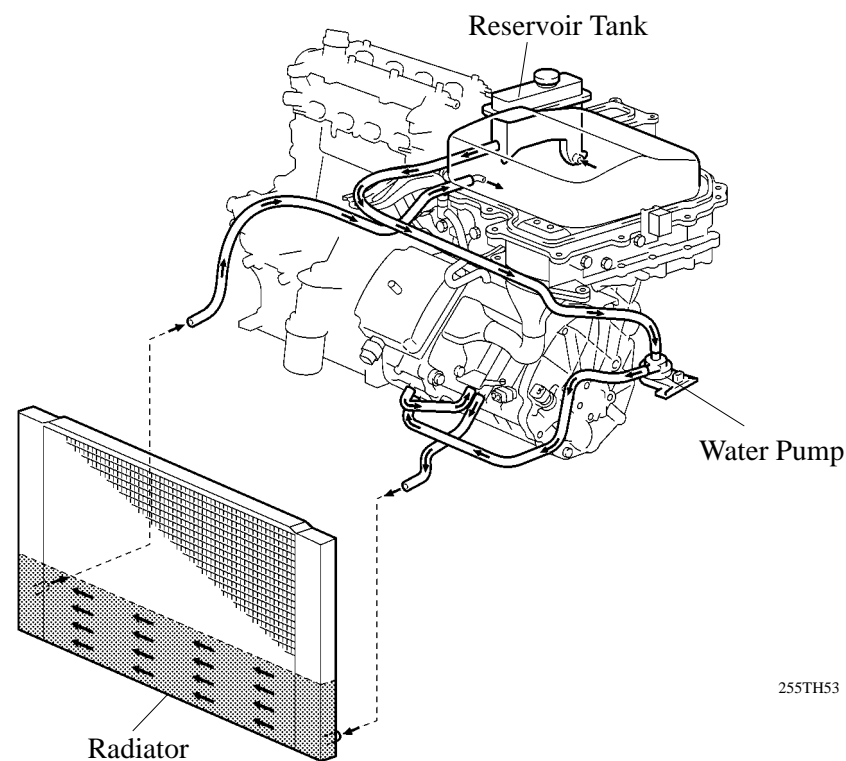

► Specifications ◀

Water Pump	Discharge Volume	liter / min.	10 or above (65 °C (149 °F))
	Capacity	liters (US qts, Imp. qts)	2.7 (2.9, 2.4)
Coolant	Type	TOYOTA Genuine Super Long Life Coolant (SLLC) or Equivalent	
	Color	Pink	
	Maintenance Intervals	First Time	100,000 mile (160,000 km)
		Subsequent	Every 50,000 mile (80,000 km)*

*: Applied only when SLLC (pink-colored) is used. If LLC (red-colored) is used, the maintenance interval would be 25,000 mile (40,000 km) or 24 months whichever comes first.

Service Tip

- When replacing SLLC, drain old coolant from the drain plug located on the lower portion of the hybrid transaxle. For details, refer to the 2004 Prius Repair Manual (Pub. No. RM1075U).
- The above-mentioned maintenance intervals become inaccurate in those cases where coolant other than SLLC has been used to replenish coolant levels between interval periods.
- You can also apply the new maintenance interval (every 50,000 mile (80,000 km)) to vehicles initially filled with LLC (red-colored), if you use SLLC (pink-colored) for the coolant change.

4. HV Battery

General

- As on the '03 Prius, the '04 Prius has adopted sealed nickel hydride (Ni-MH) batteries for the HV battery. This HV battery has a high power density, it is lightweight, and it offers longevity to match the characteristics of the THS-II system. Because the THS-II system effects charge/discharge control to maintain the HV battery at a constant level of SOC (state of charge) while the vehicle is operating normally, it does not rely on the use of external recharges.
- The HV battery, battery ECU, and SMR (System Main Relay) enclosed in a signal case and placed in the luggage compartment behind the rear seat to make more effective use of vehicle space.
- A service plug that shuts off the circuit is provided in the middle of the 28 modules (Between No.19 module and No.20 module). Before servicing any portion of the high-voltage circuit, make sure to remove the service plug.
- To ensure the HV battery's performance considering the heat that is generated in the HV battery during charging and discharging, the battery ECU controls the operation of the cooling fan.

— Main Changes from '03 Prius —

- The HV battery of the '03 Prius consists of 228 cells ($\{1.2\text{V} \times 6 \text{ cells}\} \times 38 \text{ modules}$) with a nominal voltage of DC 273.6 V. In contrast, the HV battery of the '04 Prius consists of 168 cells ($\{1.2\text{V} \times 6 \text{ cells}\} \times 28 \text{ modules}$) with a nominal voltage of 201.6V. A compact and lightweight battery configuration has been achieved through these internal improvements.
- On the '03 Prius, the connection between the cells of the HV battery consists of one spot. In contrast, the cells on the '04 Prius are connected with two spots. The internal resistance of the battery has been reduced by this improvement.

Layout of Main Components

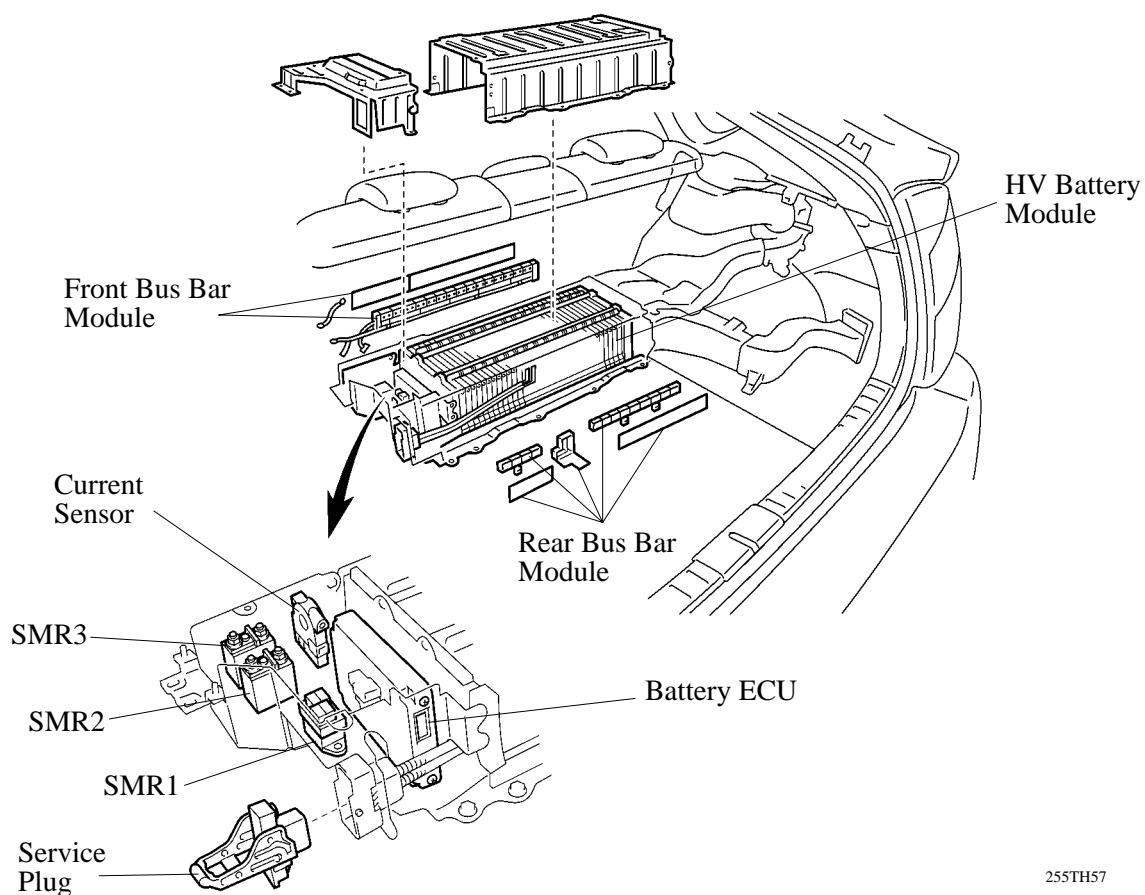

HV Battery Module

On the '03 Prius, the connection between the cells of the HV battery consists of one spot at the upper part of the cells. In contrast, the cells on the '04 Prius are connected with two spots, with an additional connection at the lower part of the cells. The internal resistance of the battery has been reduced by this improvement.

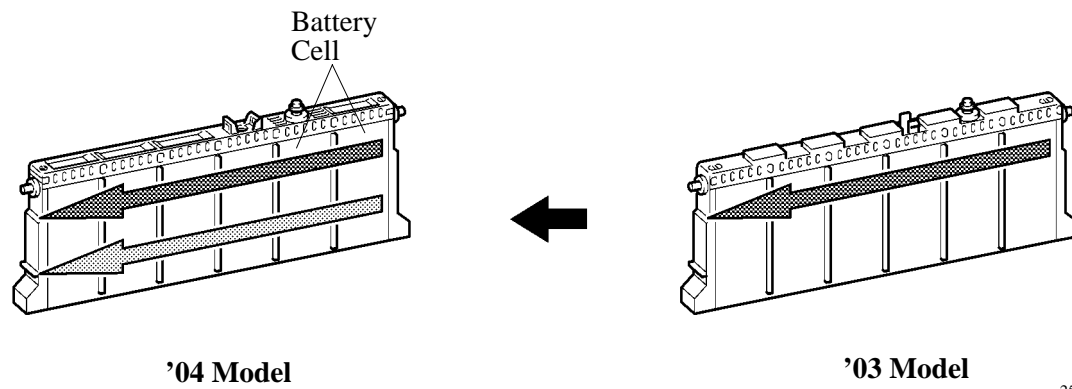

255TH58

Service Plug

By removing the service plug before performing any inspection or service, the high-voltage circuit is shut off at the intermediate position of the HV battery, thus ensuring safety during service.

The service plug assembly contains a lead switch for interlock. Lifting the clip lock up turns OFF the lead switch, which shuts off the SMR. However, to ensure safety, make sure to turn OFF the ignition switch before removing the service plug.

The main fuse for the high-voltage circuit is provided inside of the service plug assembly.

For further details on how to handle the service plug and other safety cautions, refer to the '04 Prius Repair Manual (Pub. No. RM1075U).

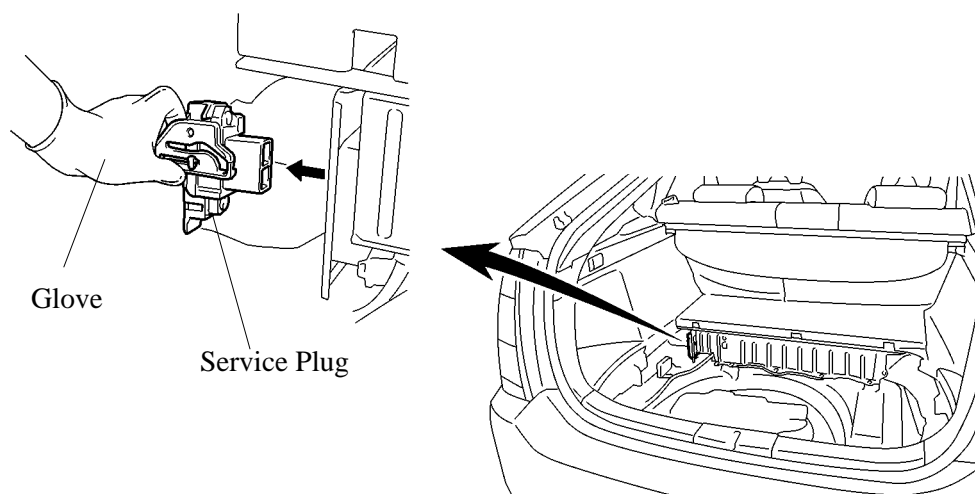

255TH59

Service Tip

After the service, please do not start the system until the service plug is connected. The battery ECU may break down.

HV Battery Cooling System

- To ensure the proper performance of the HV battery while it generates heat during the repetitive charge and discharge cycles, a dedicated cooling system for the HV battery has been adopted.
- A cooling fan is provided on the right side of the luggage compartment, in order to draw the cabin air by way of the air intake located at the right side of the rear seat. Thereafter, the intake air that has entered from the top right area of the battery flows between the battery modules from the top to the bottom to cool the battery modules. Then, the air flows through the exhaust duct and the cabin, in order to be discharged outside of the vehicle.
- The battery ECU controls the operation of the cooling fan. The battery ECU controls the temperature of the HV battery to an appropriate level in accordance with the signals provided by the three battery temperature sensors that are built into the HV battery, and one intake air temperature sensor. For details, refer to the Battery ECU Control on page TH-53.

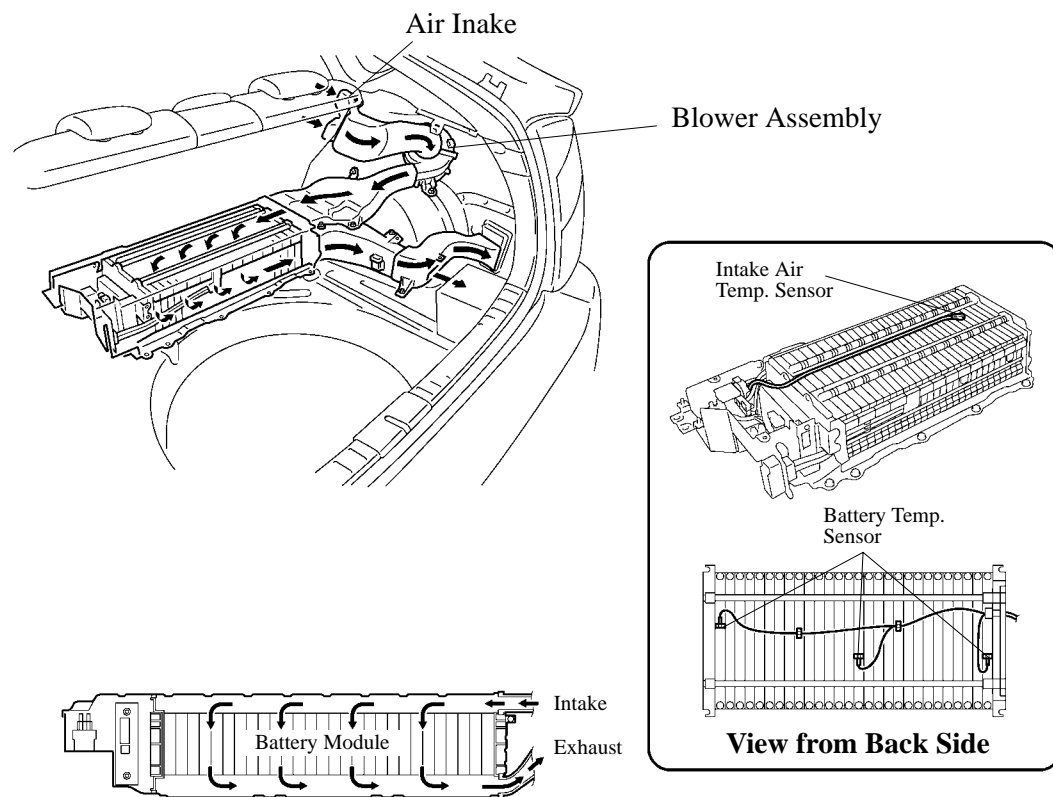

255TH60

► **Specifications** ◀

Model		'04 Prius	'03 Prius		
Type		Sirocco Fan	←		
Fan Size Dia. × H	mm (in.)	100 × 50 (4.0 × 2.0)	100 × 40 (4.0 × 1.6)		
Motor Type		DC Motor	←		
Air Flow Volume	m ³ /h	Step-less Control		3-step Control	
		Min.	40	Lo	50
		Max.	150	Mid	100
Power Consumption	W	50 or less	60		

5. Accelerator Pedal Position Sensor

The magnetic yoke that is mounted at the base of the accelerator pedal arm rotates around the Hall IC in accordance with the amount of effort that is applied to the accelerator pedal. The Hall IC converts the changes in the magnetic flux that occur at that time into electrical signals, and outputs them in the form of accelerator pedal effort to the HV ECU.

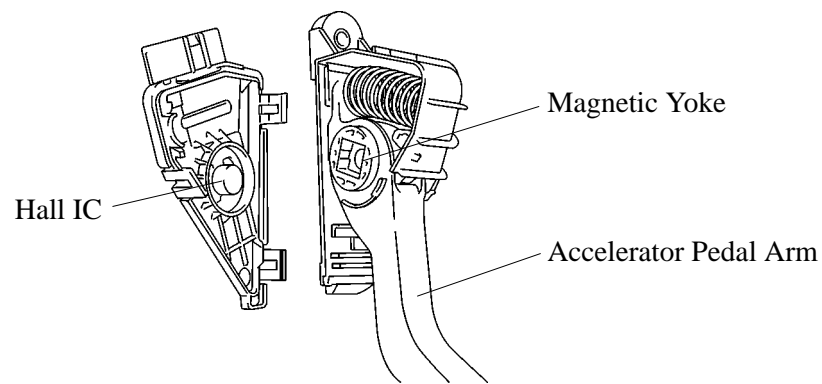

228TU23

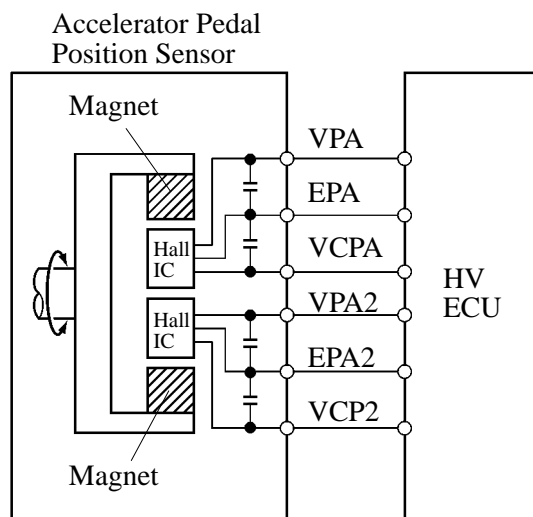

228TU24

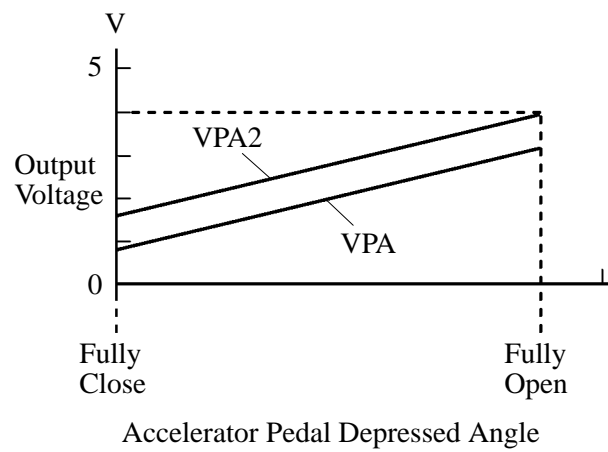

228TU25

Service Tip

The inspection method differs from the conventional accelerator pedal position sensor because this sensor uses a hall IC. For details, refer to the 2004 Prius Repair Manual (Pub. No. RM1075U.)

6. Power Cable

The power cable is a high-voltage, high-amperage cable that connects the HV battery with the inverter, the inverter with MG1 and MG2, and inverter with A/C compressor. Starting from the connector at the left front of the HV battery located in the luggage compartment, the power cable is routed under the rear seat, through the floor panel, along the under-the-floor reinforcement, and connects to the inverter in the engine compartment. A shielded cable is used for the power cable in order to reduce electromagnetic interference. The DC 12 V (+) wiring of the auxiliary battery also follows the same route.

For identification purposes, the high-voltage wiring harness and connectors are color-coded orange to distinguish them from those of the ordinary low-voltage wiring.

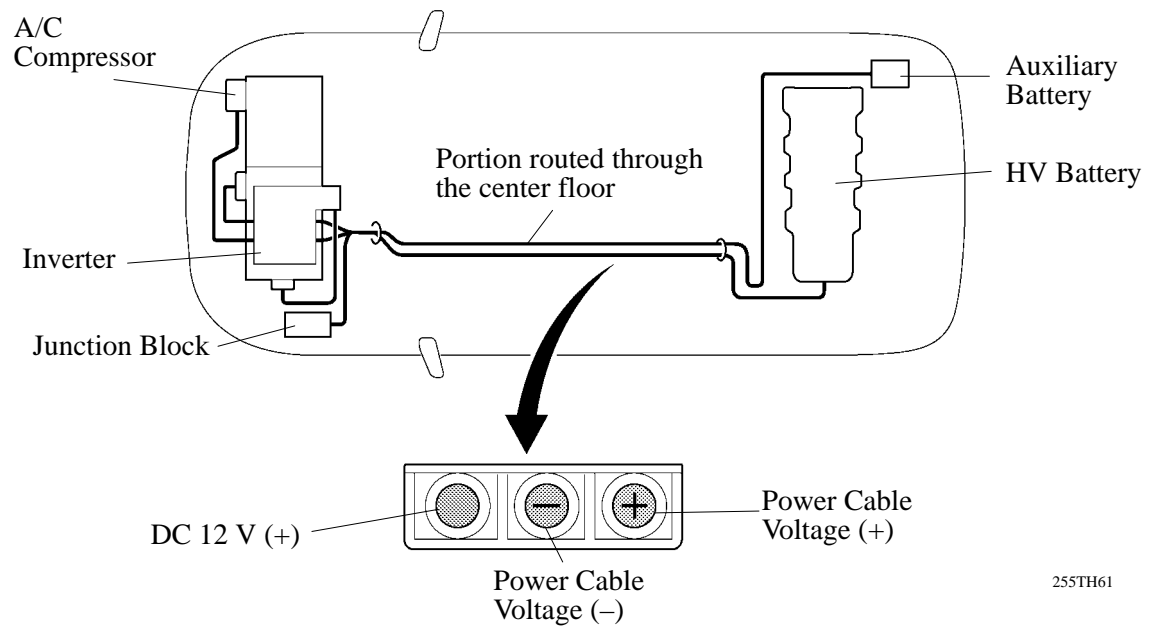

255TH61

7. Auxiliary Battery

The '04 Prius uses a shielded, maintenance-free DC 12 V battery as the auxiliary battery. Depending on a destination or equipment items, either of the battery types, S34B20R or S46B24R, will be equipped.

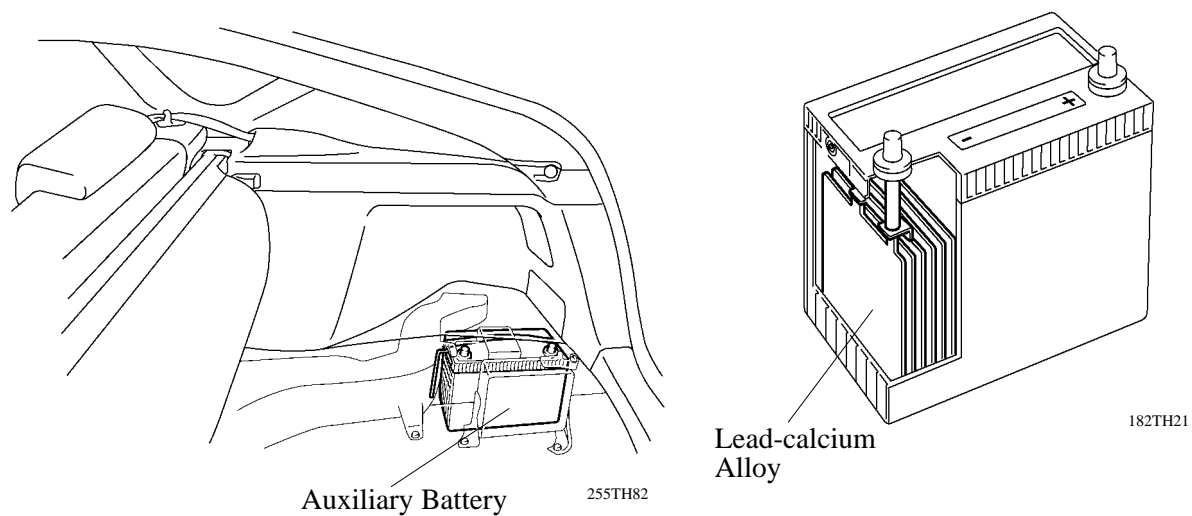

182TH21

Service Tip

Battery fluid is filtered into separators in order to reduce hydrogen gas released which occurs when the battery is charged.

Therefore, battery fluid does not need to be replaced, as long as the specified battery is used.