

# FRONT DOOR WINDOW FRAME MOULDING REPLACEMENT

7615Q-01

## HINT:

- Use the same procedures for the RH side and LH side.
- The procedures listed below are for the LH side.
- When replacing the moulding, heat the body and moulding using a heat light.

### Heating temperature:

Item	Temperature
Body	40 to 60°C (104 to 140°F)
Moulding	20 to 30°C (68 to 86°F)

## NOTICE:

Do not heat the body and moulding excessively.

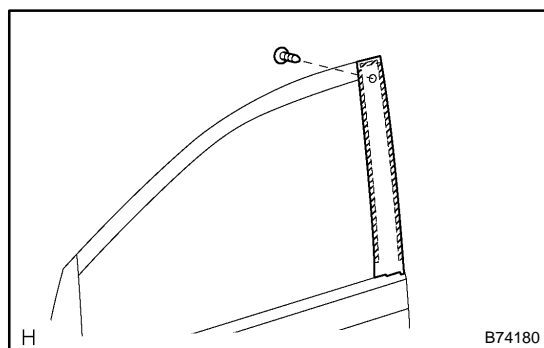

## 1. REMOVE FRONT DOOR WINDOW FRAME MOULDING

- Remove the screw.
- Using a heat light, heat the moulding.
- Remove the moulding.

### NOTICE:

If planning to reuse the moulding, take care not to damage the moulding.

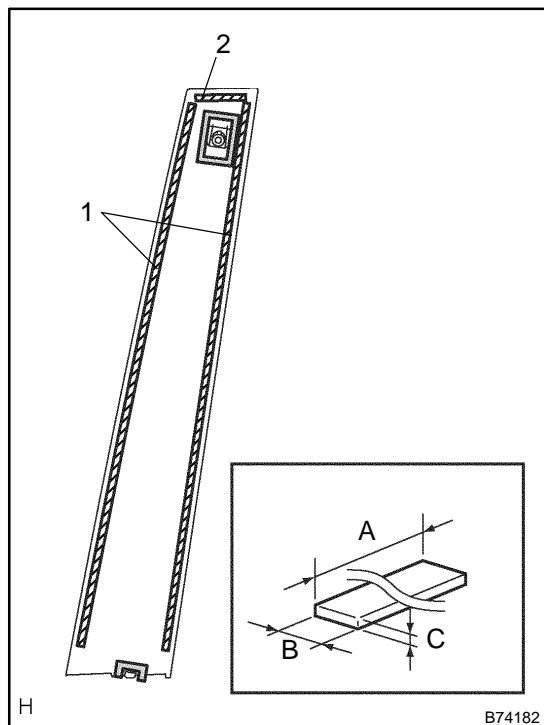

## 2. INSTALL FRONT DOOR WINDOW FRAME MOULDING

- Using a shop rag, remove the tape from the moulding.
- Clean the contact surface of the body with a shop rag saturated with white gasoline.
- Clean the outer edges of the moulding with white gasoline.
- Apply new double-sided tape to the moulding, as shown in the illustration.

### Specification:

Area	Measurement
A	1: 440 mm (17.32 in.)
	2: 37 mm (1.46 in.)
B	5.0 mm (0.197 in.)
C	0.8 mm (0.032 in.)

- Using a heat light, heat the body and moulding.
- Remove the peeling paper from the moulding face.
- Install the moulding with a screw.