

OVERHAUL

HINT:

COMPONENTS for condenser assy: See page 55-39.

1. **DISCHARGE REFRIGERANT FROM REFRIGERATION SYSTEM (SEE PAGE 55-12)**
SST 07110-58060 (07117-58080, 07117-58090, 07117-78050, 07117-88060, 07117-88070, 07117-88080)
2. **REMOVE FRONT FENDER LINER LH**
3. **REMOVE FRONT FENDER LINER RH**
4. **REMOVE FRONT BUMPER COVER**
5. **REMOVE INVERTER BRACKET NO.1 (SEE PAGE 16-33)**

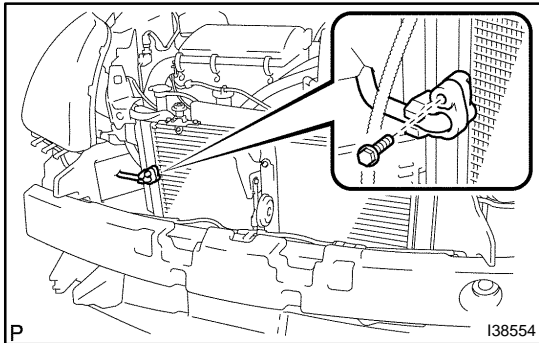

6. DISCONNECT DISCHARGE HOSE SUB-ASSY

- (a) Remove the bolt and disconnect the discharge hose sub-assy from the condenser assy (w/ receiver).
- (b) Remove the O-ring from the discharge hose sub-assy.

NOTICE:

Seal the openings of the disconnected parts of the discharge hose and the condenser assy using vinyl tape to prevent moisture and foreign matter from entering.

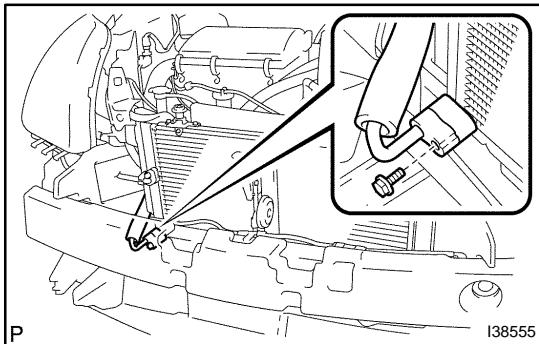

7. DISCONNECT COOLER REFRIGERANT LIQUID PIPE E (TO COOLER UNIT)

- (a) Remove the bolt and disconnect the cooler unit refrigerant liquid pipe E from the condenser assy (w/ receiver).
- (b) Remove the O-ring from the cooler refrigerant liquid pipe E.

NOTICE:

Seal the openings of the disconnected parts of the cooler unit refrigerant liquid pipe E and the condenser assy using vinyl tape to prevent moisture and foreign matter from entering.

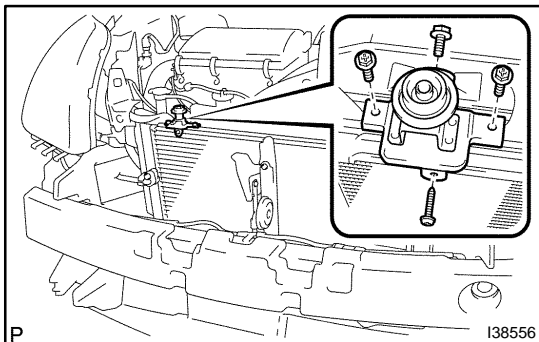

8. REMOVE RADIATOR SUPPORT SUB-ASSY UPPER RH

- (a) Remove the 4 bolts and then the radiator support sub-assy upper RH.

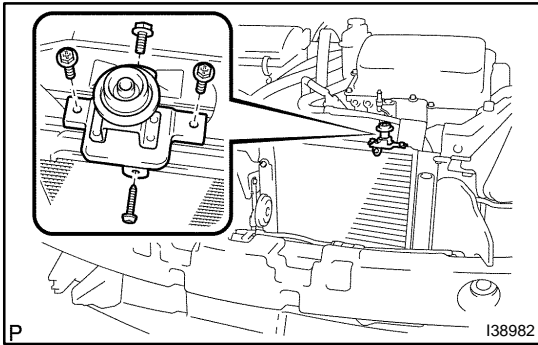

9. REMOVE RADIATOR SUPPORT SUB-ASSY UPPER LH

- (a) Remove the 4 bolts and then the radiator support sub-assy upper LH.

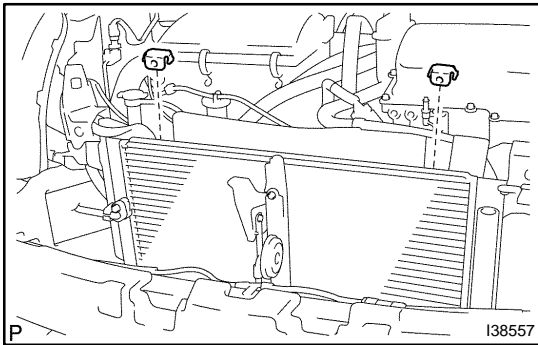

10. REMOVE W/RECEIVER CONDENSER ASSY

- (a) Remove the 2 angles.

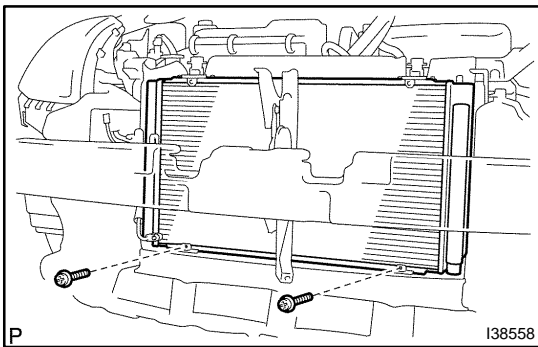

- (b) Remove the 2 bolts and then the condenser assy (w/receiver).

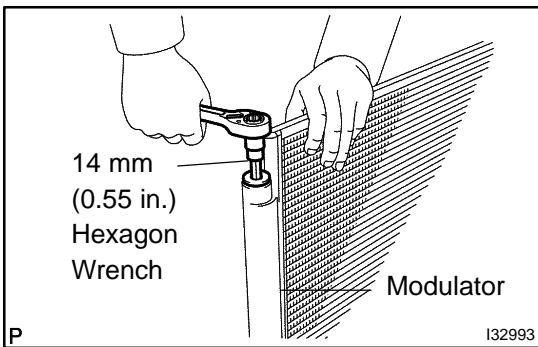

11. REMOVE COOLER DRYER

- (a) Using the straight hexagon wrench 14mm (0.55 in.), remove the cap from the modulator.

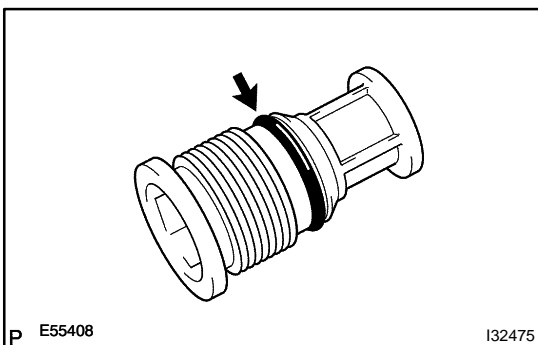

- (b) Remove the O-ring from the cap.

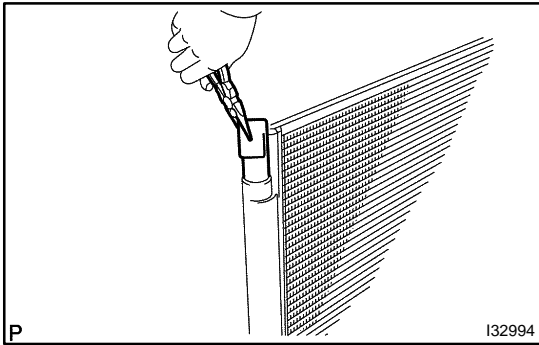

- (c) Using pliers, remove the cooler dryer.

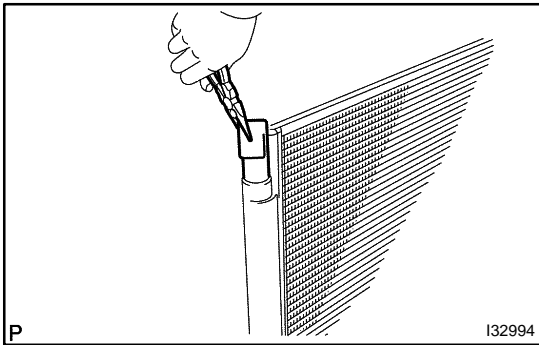

12. INSTALL COOLER DRYER

- (a) Using pliers, install the cooler dryer to the modulator.
 (b) Install a new O-ring to the cap.

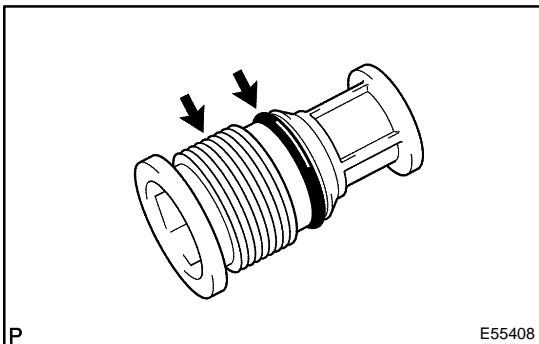

- (c) Sufficiently apply compressor oil (ND-OIL11) to the O-ring and cap fitting surface.

Compressor oil: ND-OIL 11 or equivalent

NOTICE:

- Do not use any compressor oil other than ND-OIL11 (see page 55-1).
- If any compressor oil other than ND-OIL11 is used, compressor motor insulation performance may decrease, resulting in a leakage of electric power.

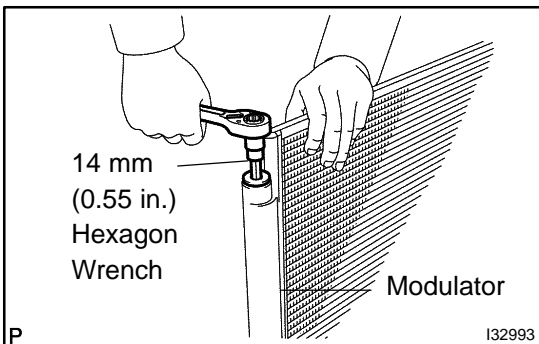

- (d) Using a straight hexagon wrench 14mm (0.55 in.), install the cap to the cooler condenser core .
Torque: 2.9 N·m (30 kgf·cm, 25 in.-lbf)

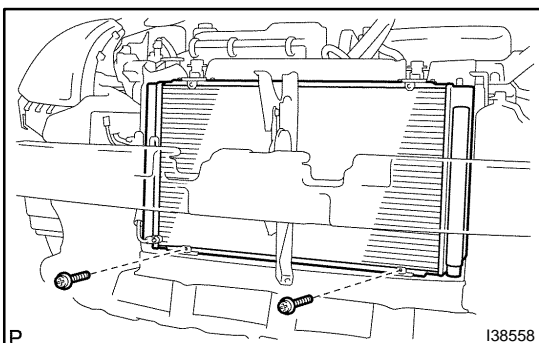

13. INSTALL W/RECEIVER CONDENSER ASSY

- (a) Install the condenser assy (w/ receiver) with 2 bolts.
Torque: 3.9 N·m (40 kgf·cm, 35 in.-lbf)

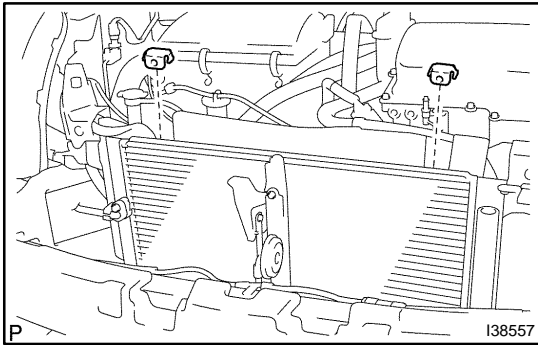

- (b) Install the 2 angles to the condenser assy (w/ receiver).

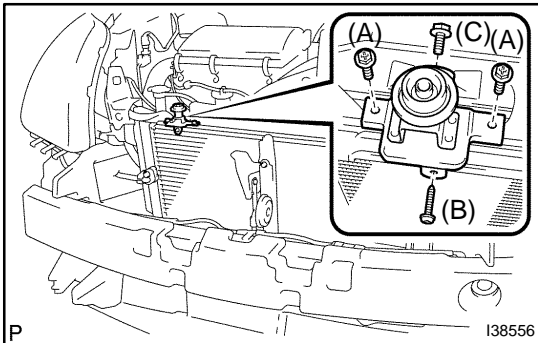

14. INSTALL RADIATOR SUPPORT SUB-ASSY UPPER RH

- (a) Install the radiator support sub-assy upper RH with the 4 bolts.

Torque:

Bolt A: 5.0 N·m (51 kgf·cm, 44 in·lbf)

Bolt B: 3.9 N·m (40 kgf·cm, 35 in·lbf)

Bolt C: 7.5 N·m (76 kgf·cm, 66 in·lbf)

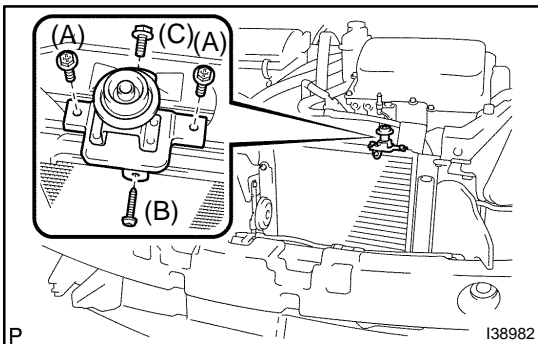

15. INSTALL RADIATOR SUPPORT SUB-ASSY UPPER LH

- (a) Install the radiator support sub-assy upper LH with the 4 bolts.

Torque:

Bolt A: 5.0 N·m (51 kgf·cm, 44 in·lbf)

Bolt B: 3.9 N·m (40 kgf·cm, 35 in·lbf)

Bolt C: 7.5 N·m (76 kgf·cm, 66 in·lbf)

16. INSTALL COOLER REFRIGERANT LIQUID PIPE E (TO COOLER UNIT)

- (a) Remove the attached vinyl tape from the disconnected parts of the cooler refrigerant liquid pipe E and condenser assy (w/ receiver).

- (b) Install a new O-ring to the cooler refrigerant liquid pipe E.

- (c) Sufficiently apply compressor oil (ND-OIL11) to the O-ring and the cooler refrigerant liquid pipe E fitting surface.

Compressor oil: ND-OIL 11 or equivalent

NOTICE:

- Do not use any compressor oil other than ND-OIL11 (see page 55-1).
- If any compressor oil other than ND-OIL11 is used, compressor motor insulation performance may decrease, resulting in a leakage of electric power.

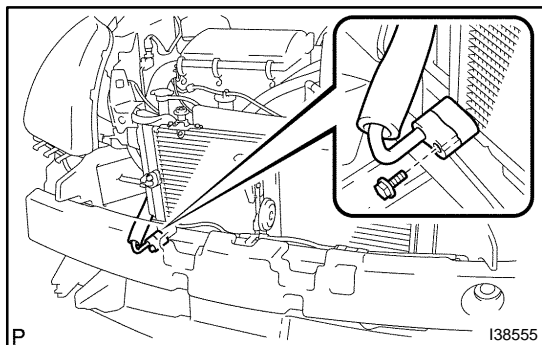

- (d) Install the cooler refrigerant liquid pipe E to the condenser assy (w/ receiver) with the bolt.

Torque: 5.4 N·m (55 kgf·cm, 47 in.-lbf)

17. INSTALL DISCHARGE HOSE SUB-ASSY

- (a) Remove the attached vinyl tape from the disconnected parts of the discharge hose sub-assy and the condenser assy (w/ receiver).
- (b) Install a new O-ring to the discharge hose sub-assy.
- (c) Sufficiently apply compressor oil (ND-OIL11) to the O-ring and the discharge hose fitting surface.

Compressor oil: ND-OIL 11 or equivalent

NOTICE:

- Do not use any compressor oil other than ND-OIL11 (see page 55-1).
- If any compressor oil other than ND-OIL11 is used, compressor motor insulation performance may decrease, resulting in a leakage of electric power.

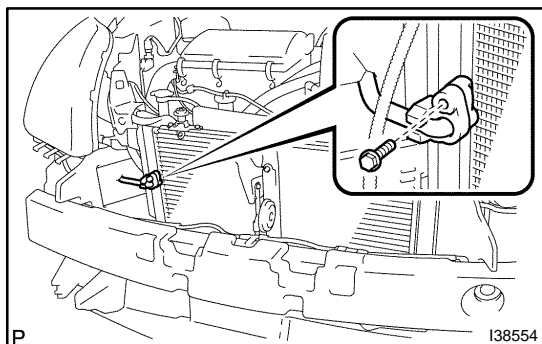

- (d) Install the discharge hose to the condenser assy (w/ receiver) with the bolt.

Torque: 5.4 N·m (55 kgf·cm, 47 in.-lbf)

18. INSTALL INVERTER BRACKET NO.1 (SEE PAGE 16-33)

19. INSTALL FRONT BUMPER COVER

20. INSTALL FRONT FENDER LINER RH

21. INSTALL FRONT FENDER LINER LH

22. CHARGE REFRIGERANT (SEE PAGE 55-12)

SST 07110-58060 (07117-58060, 07117-58070, 07117-58080, 07117-58090, 07117-78050, 07117-88060, 07117-88070, 07117-88080)

Specified amount: 450 ± 30 g (15.87 ± 1.05 oz.)

23. WARM UP COMPRESSOR (SEE PAGE 55-12)

24. INSPECT LEAKAGE OF REFRIGERANT (SEE PAGE 55-12)