

# INPUT SHAFT OIR SEAL REPLACEMENT

22015-01

## NOTICE:

- When working on the high voltage systems, always wear insulated gloves.
  - After removing the service plug grip, do not operate the power switch as it may damage the hybrid vehicle control ECU.
  - Keep the removed service plug in your pocket to prevent other technicians from reconnecting it while you are servicing the vehicle.
  - After removing the service plug grip, do not touch the high voltage connectors and terminals for 5 minutes.
1. REMOVE HYBRID VEHICLE TRANSAXLE ASSY (SEE PAGE 22-11)

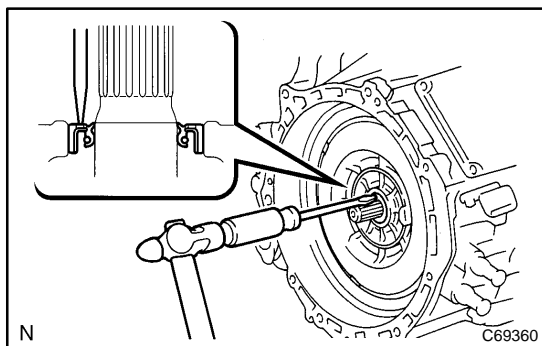

## 2. REMOVE INPUT SHAFT OIR SEAL

- (a) Drive a flat-head screwdriver into the metal portion of the oil seal and remove the oil seal.

### NOTICE:

Do not damage the input shaft and transaxle housing when driving the screwdriver or removing the oil seal.

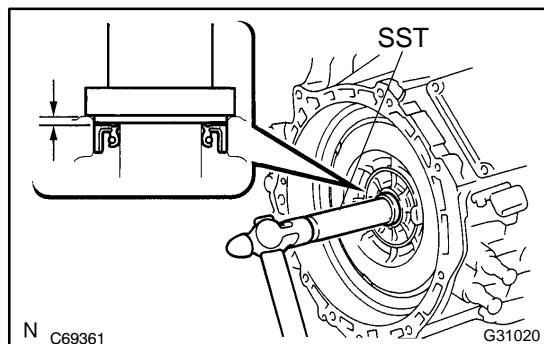

## 3. INSTALL INPUT SHAFT OIR SEAL

- (a) Apply a small amount of MP grease No.2 to the oil seal lip.
- (b) Using SST, install a new oil seal.

SST 09388-40010

**Oil seal drive in depth:**

**1.0 to 1.5 mm (0.0393 ± 0.0590 in.)**

### NOTICE:

- Ensure that no foreign objects adhere to the oil seal lip.
- Ensure that the oil seal is fitted straight.

4. INSTALL HYBRID VEHICLE TRANSAXLE ASSY (SEE PAGE 22-11)