

<b>DTC</b>	<b>P0851/579</b>	<b>PARK/NEUTRAL SWITCH INPUT CIRCUIT LOW</b>
------------	------------------	--

<b>DTC</b>	<b>P0852/580</b>	<b>PARK/NEUTRAL SWITCH INPUT CIRCUIT HIGH</b>
------------	------------------	---

**CIRCUIT DESCRIPTION**

Instead of having a parking position as one of the positions of the conventional shift lever, a P position switch is provided independently in the upper area of the selector lever. The switch is based on a momentary type operation mode, in which the button does not lock mechanically.

The P position switch contains resistors R1 and R2. When the P position switch is not pressed, the switch provides a combined resistance of R1 and R2; and when the P position switch is pressed, the switch provides only the resistance of R1. The voltage at the P1 terminal of the HV control ECU varies with the changes in the resistance of the switch. The HV control ECU determines the P position switch operation intended by the driver according to this resistance signal.

DTC No.	INF Code	DTC Detection Condition	Trouble Area
P0851	579	GND short in P position switch circuit	<ul style="list-style-type: none"> <li>• Wire harness or connector</li> <li>• P position switch</li> <li>• HV control ECU</li> </ul>
P0852	580	Open or +B short in P position switch circuit	<ul style="list-style-type: none"> <li>• Wire harness or connector</li> <li>• P position switch</li> <li>• HV control ECU</li> </ul>

**WIRING DIAGRAM**

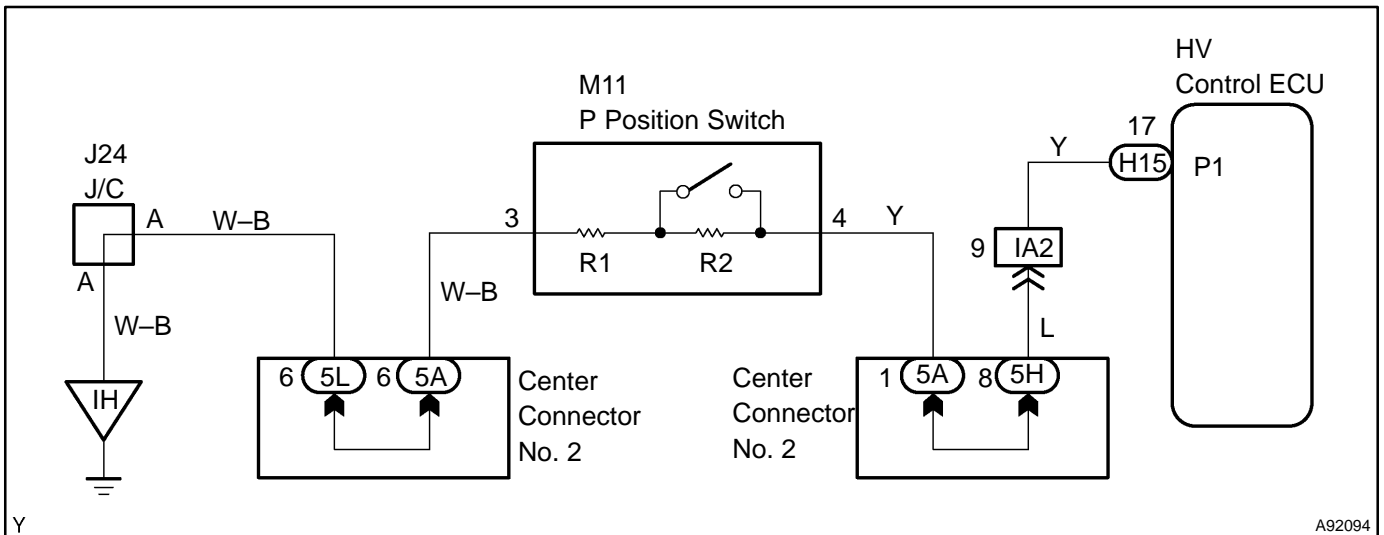

Y

A92094

# INSPECTION PROCEDURE

## 1 INSPECT P POSITION SWITCH

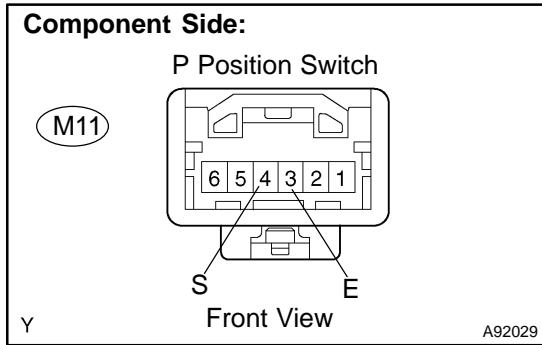

- (a) Remove the P position switch.
- (b) Check the resistance between the terminals of the P position switch connector.

**Standard:**

Symbols (Terminal No.)	Condition	Resistance
S (M11-4) – E (M11-3)	Keep switch pressed	680 Ω
S (M11-4) – E (M11-3)	Release switch	4,580 Ω

- (c) Reinstall the P position switch.

**NG** → REPLACE P POSITION SWITCH

**OK**

## 2 CHECK HARNESS AND CONNECTOR(HYBRID VEHICLE CONTROL ECU – P POSITION SWITCH)

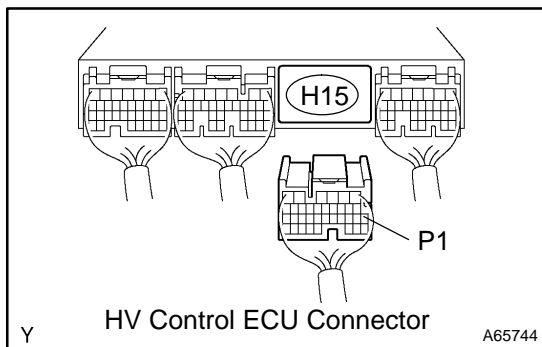

- (a) Disconnect the H15 HV control ECU connector.
- (b) Disconnect the M11 P position switch connector.
- (c) Turn the power switch ON (IG).
- (d) Measure the voltage between the terminal of the HV control ECU connector and body ground.

**Standard:**

Tester Connection	Specified Condition
P1 (H15-17) – Body ground	Below 1 V

- (e) Turn the power switch OFF.
- (f) Check the resistance between the wire harness side connectors.

**Standard (Check for open):**

Tester Connection	Specified Condition
P1 (H15-17) – S (M11-4)	Below 1 Ω

**Standard (Check for short):**

Tester Connection	Specified Condition
P1 (H15-17) or S (M11-4) – Body ground	10 kΩ or higher

- (g) Reconnect the P position switch connector.
- (h) Reconnect the the HV control ECU connector.

**NG** → REPAIR OR REPLACE HARNESS OR CONNECTOR

**OK**

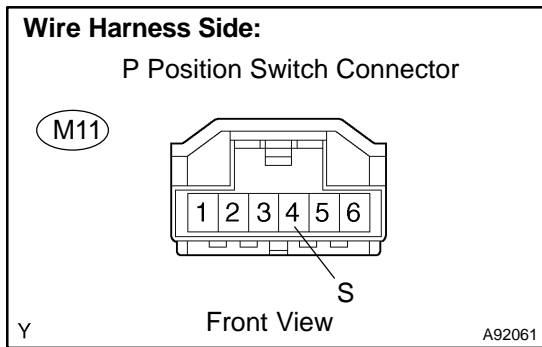

**3 CHECK HARNESS AND CONNECTOR(P POSITION SWITCH – BODY GROUND)**

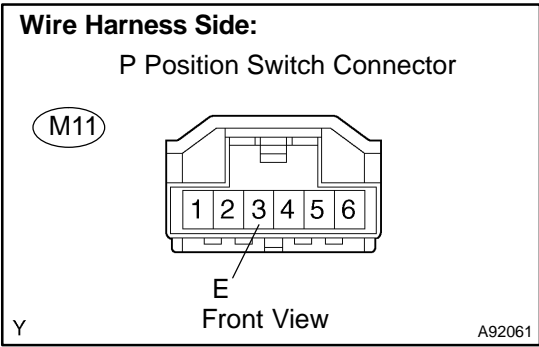

- (a) Disconnect the M11 P position switch connector.
- (b) Check the resistance between the terminal of the P position switch connector and body ground.

**Standard (Check for open):**

Tester Connection	Specified Condition
E (M11-3) – Body ground	Below 1 Ω

- (c) Reconnect the P position switch connector.

**NG** → **REPAIR OR REPLACE HARNESS OR CONNECTOR**

**OK**

**REPLACE HYBRID VEHICLE CONTROL ECU (See page 21-124)**