

<b>DTC</b>	<b>P3056</b>	<b>BATTERY CURRENT SENSOR CIRCUIT MALFUNCTION</b>
------------	--------------	---

### CIRCUIT DESCRIPTION

The battery current sensor, which is mounted on the negative cable side of the HV battery assembly, detects the amperage that flows into the HV battery. The battery current sensor inputs a voltage (which varies between 0 to 5 V in proportion to the amperage) into the IB terminal of the battery ECU. An output voltage of the battery current sensor below 2.5 V indicates that the HV battery assembly is being charged, and above 2.5 V indicates that the HV battery assembly is being discharged.

The battery ECU determines the charging and discharging amperage of the HV battery assembly based on the signals that are input to its IB terminal, and calculates the SOC (state of charge) of the HV battery through the estimation of the amperage.

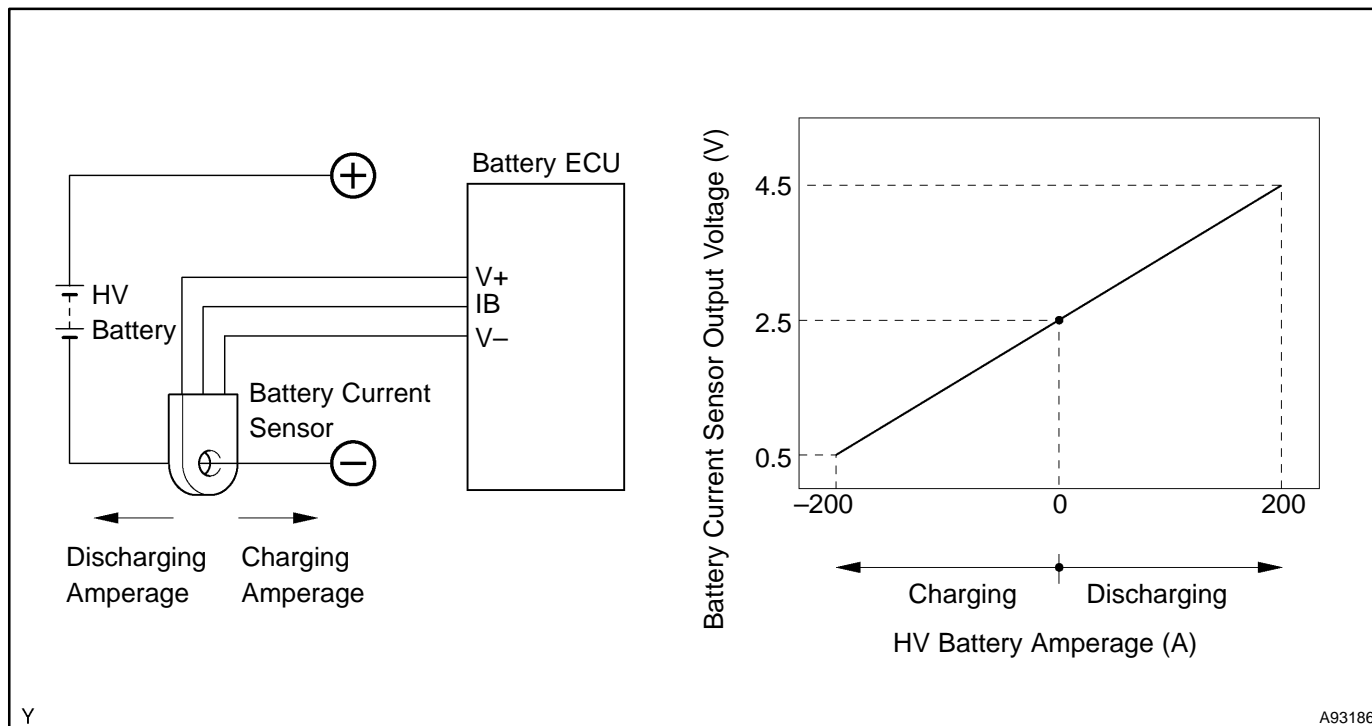

DTC No.	DTC Detection Condition	Trouble Area
P3056	Malfunction in battery current sensor (1 or 2 trip detection logic)	<ul style="list-style-type: none"> <li>• HV battery assembly (wire harness or connector)</li> <li>• Battery current sensor</li> <li>• Battery ECU</li> </ul>

### MONITOR DESCRIPTION

If the battery ECU detects malfunction in the battery current sensor, it will illuminate the MIL and set a DTC.

### MONITOR STRATEGY

Related DTCs	P3056: Battery current sensor/Range check Battery current sensor/Rationality
Required sensor/components	Battery current sensor
Frequency of operation	Continuous
Duration	TOYOTA's intellectual property
MIL operation	Rationality: Immediately Range check: Immediately or 2 driving cycles
Sequence of operation	None

### TYPICAL ENABLING CONDITIONS

The monitor will run whenever the following DTCs are not present	TOYOTA's intellectual property
Other conditions belong to TOYOTA's intellectual property	-

### TYPICAL MALFUNCTION THRESHOLDS

Battery current sensor	Abnormal
------------------------	----------

### COMPONENT OPERATING RANGE

Battery current sensor	DTC P3056 is not detected
------------------------	---------------------------

### WIRING DIAGRAM

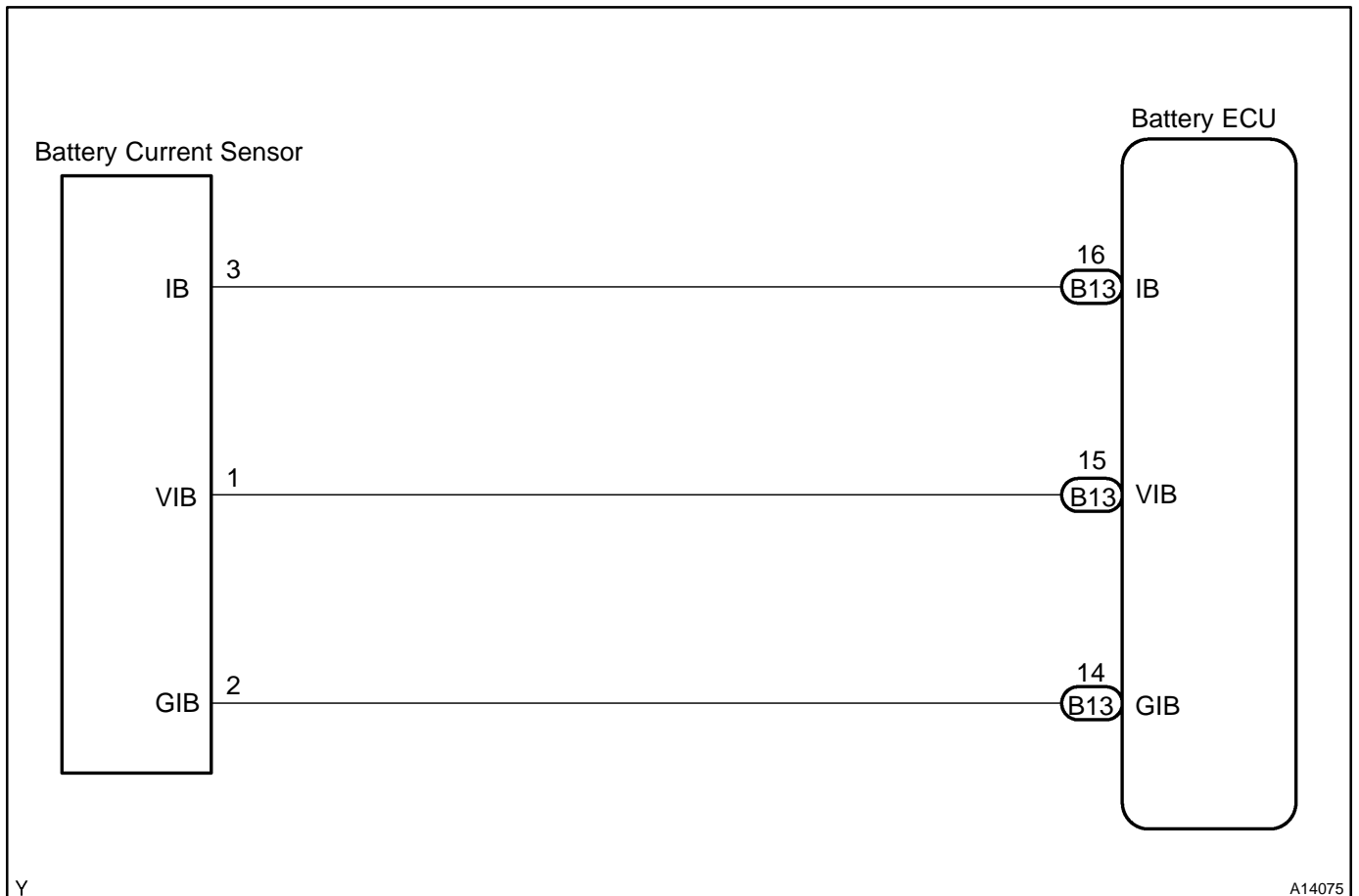

Y

A14075

## INSPECTION PROCEDURE

### CAUTION:

- Before inspecting the high-voltage system, take safety precautions to prevent electrical shocks, such as wearing insulated gloves and removing the service plug grip. After removing the service plug grip, put it in your pocket to prevent other technicians from reconnecting it while you are servicing the high-voltage system.
- After disconnecting the service plug grip, wait at least for 5 minutes before touching any of the high-voltage connectors or terminals.

### HINT:

At least 5 minutes is required to discharge the high-voltage condenser inside the inverter.

<b>1</b>	<b>READ OUTPUT DTC(DTC P0A1F IS OUTPUT)</b>
----------	---

- Connect the hand-held tester or the OBD II scan tool to the DLC3.
- Turn the power switch ON (IG).
- Turn the hand-held tester or the OBD II scan tool ON.
- On the hand-held tester, enter the following menus: DIAGNOSIS / ENHANCED OBD II / HV BATTERY / DTC INFO / TROUBLE CODES.

For the OBD II scan tool, see its instruction manual.

- Read DTCs.

**Result: DTC P0A1F is output**

**YES**

**REPLACE BATTERY ECU ASSY**  
(See page [21-98](#))

**NO**

**2 CHECK HARNESS AND CONNECTOR(BATTERY ECU – BATTERY CURRENT SENSOR)**

**CAUTION:**

Wear insulated gloves before performing the following operation.

- (a) Turn the power switch OFF.
- (b) Remove the service plug grip (see page 21-116).

**NOTICE:**

Turning the power switch ON (READY) with the service plug grip removed could cause malfunction. Therefore, never turn the power switch ON (READY) in this state.

- (c) Disconnect the B13 battery ECU connector.
- (d) Disconnect the battery current sensor connector.
- (e) Turn the power switch ON (IG).

**HINT:**

DTCs for the interlock switch system are output when turning the power switch ON (IG) with the service plug grip removed.

- (f) Measure the voltage between the terminals of the B13 battery ECU connector and body ground.

**Standard:**

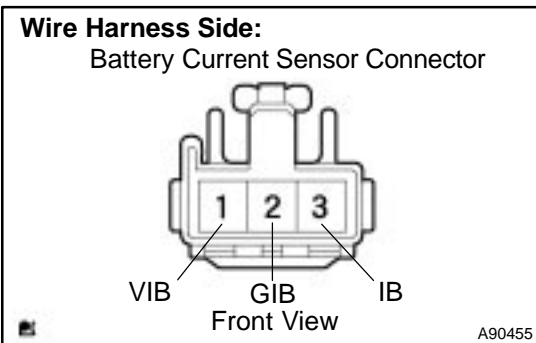
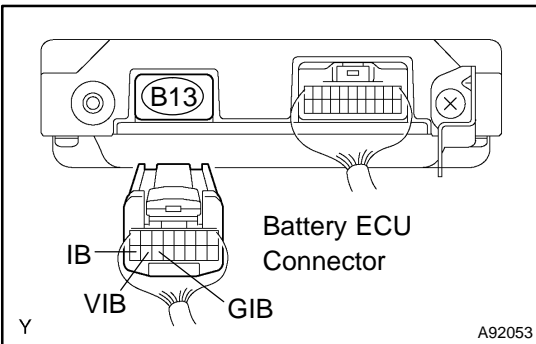

Tester Connection	Specified Condition
IB (B13-16) – Body ground	Below 1 V
GIB (B13-14) – Body ground	Below 1 V
VIB (B13-15) – Body ground	Below 1 V

- (g) Turn the power switch OFF.
- (h) Check the resistance between the wire harness side connectors.

**Standard (Check for open):**

Tester Connection	Specified Condition
IB (B13-16) – battery current sensor (3)	Below 1 Ω
GIB (B13-14) – battery current sensor (2)	Below 1 Ω
VIB (B13-15) – battery current sensor (1)	Below 1 Ω

**Standard (Check for short):**

Tester Connection	Specified Condition
IB (B13-16) or battery current sensor (3) – Body ground	10 kΩ or higher
GIB (B13-14) or battery current sensor (2) – Body ground	10 kΩ or higher
VIB (B13-15) or battery current sensor (1) – Body ground	10 kΩ or higher

- (i) Reconnect the battery current sensor connector.
- (j) Reconnect the battery ECU connector.
- (k) Reinstall the service plug grip (see page 21-116).

**HINT:**

Since the wire harness is not available as a unit and if it is impossible to repair, replace the entire HV battery assembly.

<b>NG</b>	<b>REPAIR HARNESS OR CONNECTOR, OR REPLACE HV SUPPLY BATTERY ASSY (See page 21-54)</b>
-----------	--

**OK**

**3 REPLACE BATTERY CURRENT SENSOR**

- (a) Replace battery current sensor (see page [21-95](#)).
- (b) Connect the hand-held tester or the OBD II scan tool to the DLC3.
- (c) Turn the power switch ON (IG).
- (d) Turn the hand-held tester or the OBD II scan tool ON.
- (e) On the hand-held tester, enter the following menus: DIAGNOSIS / ENHANCED OBD II / HV BATTERY / DTC INFO / CLEAR CODES.  
For the OBD II scan tool, see its instruction manual.
- (f) Perform a simulation test.

**HINT:**

Some of the steps involve the detection of 2 trips. Therefore, after performing a simulation test, turn the power switch OFF, and perform the simulation test again.

**GO****4 READ OUTPUT DTC(DTC P3056 IS NOT OUTPUT AGAIN)**

- (a) Connect the hand-held tester or the OBD II scan tool to the DLC3.
- (b) Turn the power switch ON (IG).
- (c) Turn the hand-held tester or the OBD II scan tool ON.
- (d) On the hand-held tester, enter the following menus: DIAGNOSIS / ENHANCED OBD II / HV BATTERY / DTC INFO / TROUBLE CODES.  
For the OBD II scan tool, see its instruction manual.
- (e) Read DTCs.

**Result: DTC P3056 is not output again**

**NO****REPLACE BATTERY ECU ASSY  
(See page [21-98](#))****YES****SYSTEM OK**