

# AVC-LAN CIRCUIT (MULTI-DISPLAY - GATEWAY ECU)

## CIRCUIT DESCRIPTION

Each unit of the navigation system connected to AVC-LAN (communication bus) communicates by transferring the signals from each switch.

When +B short and GND short occur in this AVC-LAN, navigation system will not function normally as communication is discontinued.

In AVC-LAN, multi-display becomes the communication master, and the radio receiver assy has enough resistance necessary for transmitting the communication.

## WIRING DIAGRAM

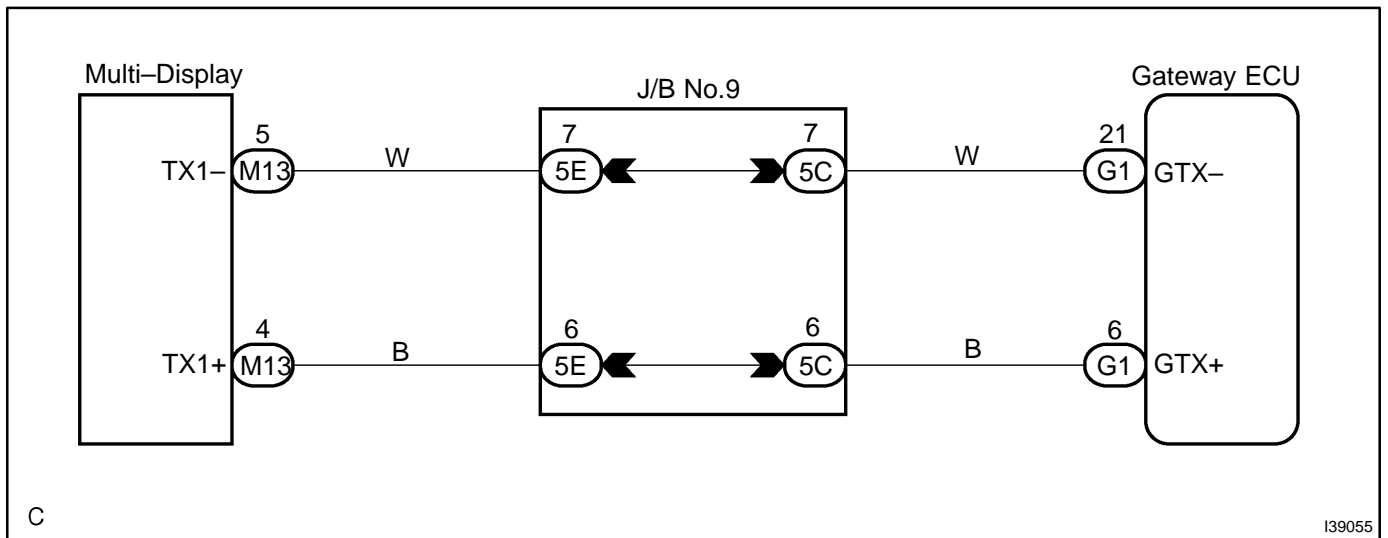

# INSPECTION PROCEDURE

## 1 CHECK HARNESS AND CONNECTOR(MULTI-DISPLAY - GATEWAY ECU)

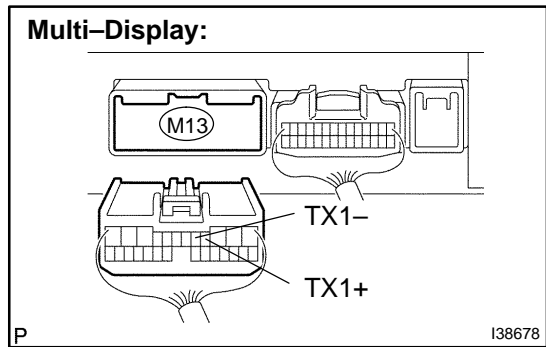

- (a) Disconnect the connector from the multi-display M13 and gateway ECU G1.
- (b) Measure the resistance according to the value(s) in the table below.

**Standard:**

Tester connection	Condition	Specified condition
TX1+ - GTX+	Always	Below 1 Ω
TX1- - GTX-	Always	Below 1 Ω
TX1+ - Body ground	Always	10 kΩ or higher
TX1- - Body ground	Always	10 kΩ or higher

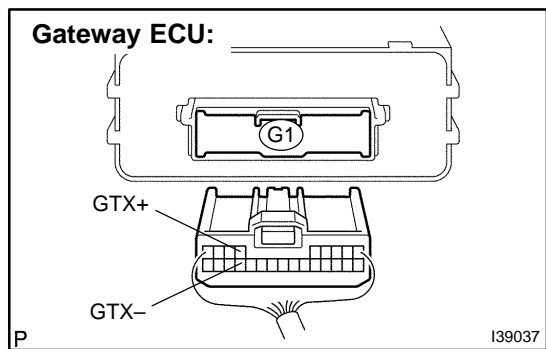

**NG** REPAIR OR REPLACE HARNESS OR CONNECTOR

**OK**

**PROCEED TO NEXT CIRCUIT INSPECTION SHOWN IN DIAGNOSTIC TROUBLE CODE CHART (SEE PAGE 05-1888)**