

POWER STEERING ECU COMMUNICATION STOP MODE

MODE DESCRIPTION

Detection Item	Symptom	Trouble Area
POWER STEERING ECU COMMUNICATION STOP MODE	<ul style="list-style-type: none"> • "EPS" is not displayed on the "BUS CHECK" screen of the hand-held tester. • Applies to "POWER STEERING ECU COMMUNICATION STOP MODE" in the "DTC COMBINATION TABLE" (see page 05-2605). 	<ul style="list-style-type: none"> • Power source or inside the power steering ECU • Power steering ECU sub bus line or connector

WIRING DIAGRAM

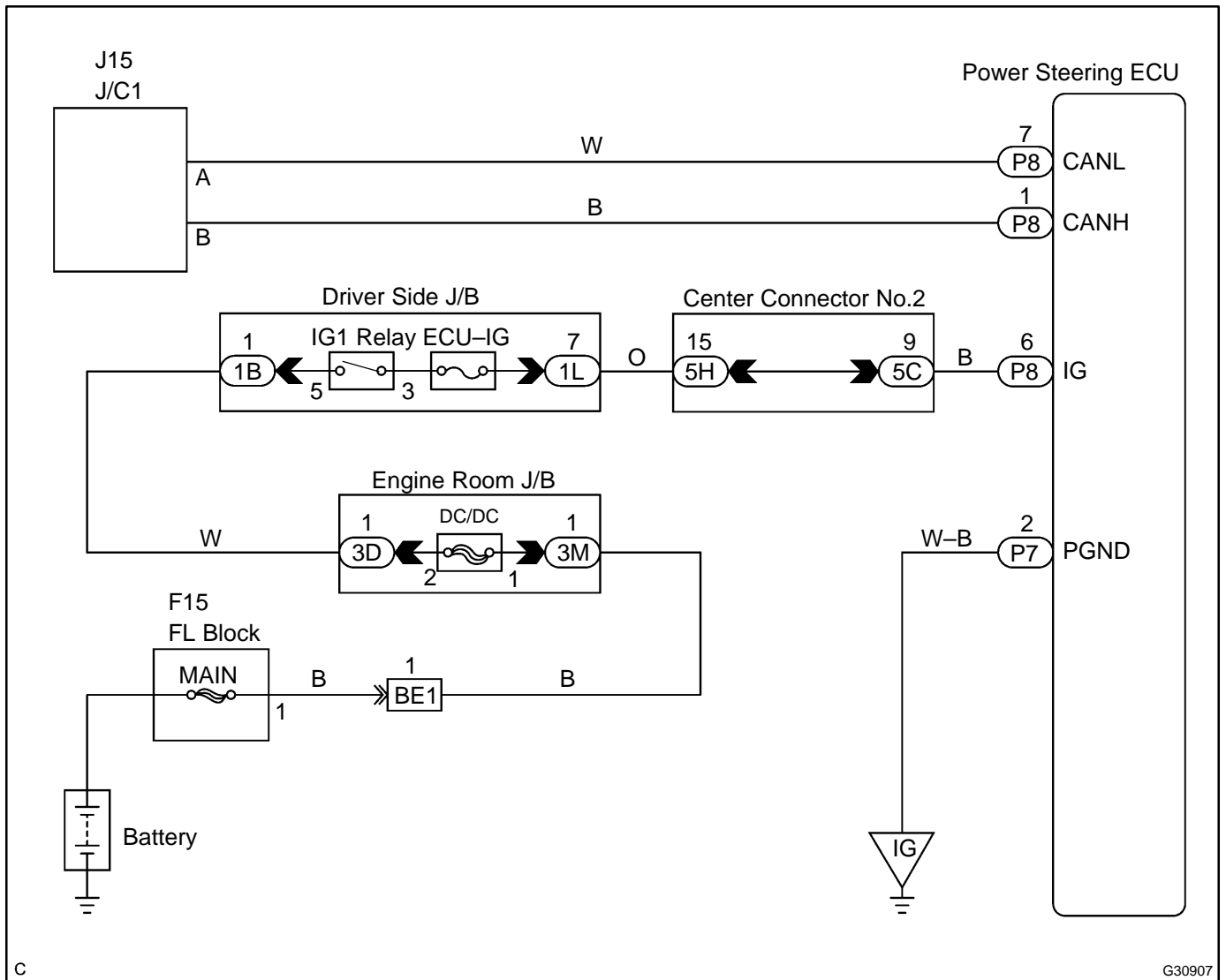

C

G30907

INSPECTION PROCEDURE

1 CHECK CAN BUS LINE FOR DISCONNECTION(Power Steering ECU Sub Bus Line)

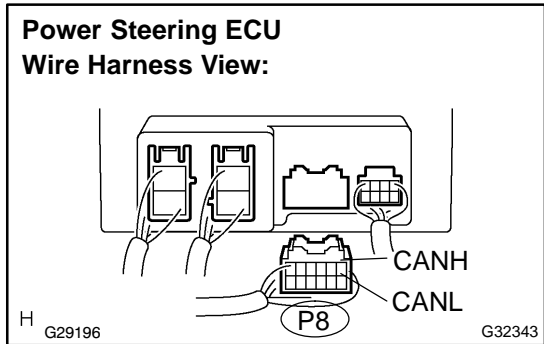

- (a) Turn the power switch off.
- (b) Disconnect the power steering ECU connector (P8).
- (c) Measure the resistance according to the value(s) in the table below.

Standard:

Tester connection	Condition	Specified value
P8-1 (CANH) – P8-7 (CANL)	Power Switch OFF	54 to 69 Ω

NG → REPLACE POWER STEERING ECU SUB BUS LINE OR CONNECTOR (CAN-H, CAN-L)

OK

2 CHECK WIRE HARNESS(IG,PGND)

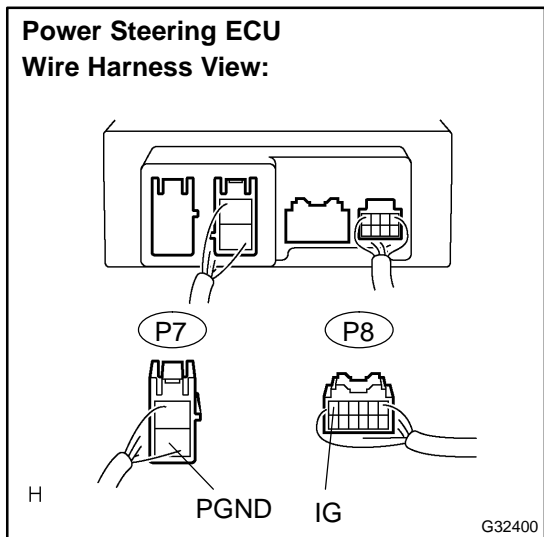

- (a) Disconnect the power steering ECU connector (P7).
- (b) Measure the resistance according to the value(s) in the table below.
- (c) Measure the voltage according to the value(s) in the table below.

Standard:

Tester connection	Condition	Specified condition
P7-2 (PGND) – Body ground	Always	Below 1 Ω
P8-6 (IG) – Body ground	Power Switch ON (IG)	10 to 14 V

NG → REPAIR OR REPLACE WIRE HARNESS OR CONNECTOR

OK

REPLACE POWER STEERING ECU ASSY (SEE PAGE 50-16)