

DTC	P1150	COOLANT PATH CLOG UP FOR COOLANT HEAT STORAGE SYSTEM
------------	--------------	---

CIRCUIT DESCRIPTION

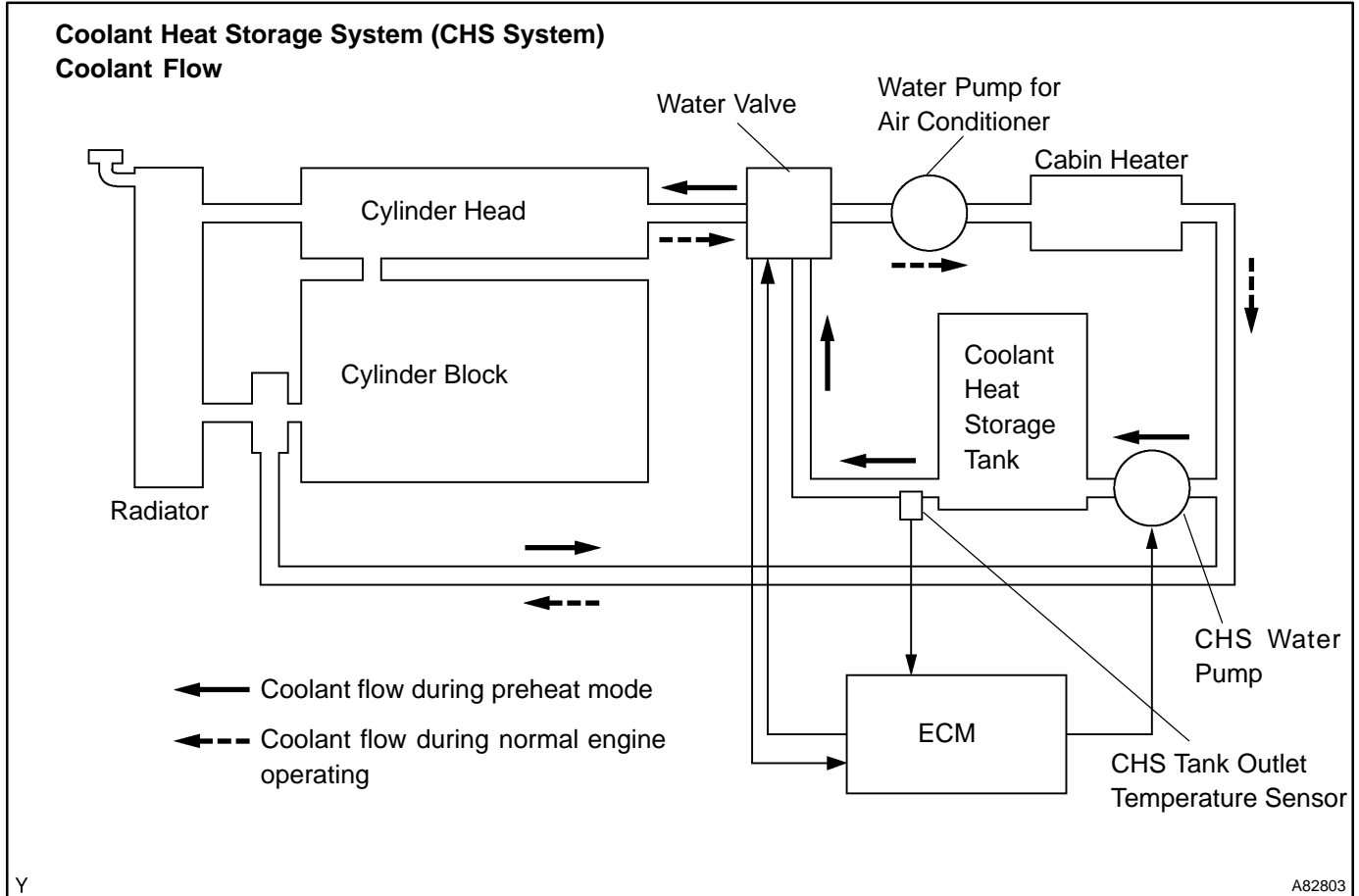

This system uses an electric pump to supply hot coolant stored in the coolant heat storage (CHS) tank into the cylinder head of the engine, in order to optimize engine starting combustion and reduce the amount of unburned gas that is discharged while the engine is started. Before the engine starts, the ECM operates the electric water pump to direct the hot coolant in the CHS tank into the engine, in order to heat the cylinder head (this process is called "preheat mode"). The duration of the operation of the electric water pump is variable, depending on the temperature of the cylinder head. During normal operation of the engine, the water valve opens the passage between the cylinder head and the heater and closes the passage between the cylinder head and the tank. During the preheat mode in which the cylinder head is heated, the water valve opens the passage between the tank and the cylinder head, in order to allow the coolant to flow from the tank to the cylinder head. At this time, in order to warm up the intake port quickly before the engine is started, the coolant flows in the reverse direction.

This system consists of the CHS tank, CHS water pump, CHS tank outlet temperature sensor, water valve, and a soak timer that is built in the ECM.

DTC No.	Detection Condition	Trouble Area
P1150	Following conditions are met: • Change in CHS tank outlet temperature and engine coolant temperature after water pump is ON during preheat mode: below 2°C (3.6 °F) • Change in CHS tank outlet temperature as water valve is opened to tank, on a warm engine: below 3°C (5.4 °F)	• CHS tank outlet temperature sensor • Water valve (Coolant flow control valve) • Cooling system (clogging) • ECM

MONITOR DESCRIPTION

The ECM detects malfunction in the coolant heat storage (CHS) system with the CHS tank outlet temperature signal, the position of the water valve and the engine running condition. In order to ensure the reliable malfunction detection, the ECM detects coolant passage clogging malfunction in two ways. Thus, when the following two detection conditions are met, the ECM determines that the coolant passage has clogged and sets a DTC.

- When starting the engine, a variation in the CHS tank outlet temperature and engine coolant temperature before and after preheating is below 2 °C (3.6 °F).
- After the engine is warmed up, a variation in the CHS tank outlet temperature when the ECM opens the water valve is below 3°C (5.4 °F).

MONITOR STRATEGY

Related DTCs	P1150: Coolant path clog up for coolant heat storage system
Required sensors/components	CHS tank outlet temperature sensor
Frequency of operation	Once per driving cycle
Duration	10 seconds
MIL operation	1 driving cycle
Sequence of operation	None

TYPICAL ENABLING CONDITIONS

The monitor will run whenever the following DTCs are not present	See page 05-20
Coolant heat storage system malfunction	Not detected
Coolant heat storage water pump operation time	3 seconds or more
Variation in CHS tank coolant temperature and engine coolant temperature before and after preheating	2°C (3.6°F) or less
Engine coolant temperature	65°C (149°F) or more

TYPICAL MALFUNCTION THRESHOLDS

Variation in CHS tank coolant temperature during passage clogging check	Less than 3°C (5.4°F)
---	-----------------------

WIRING DIAGRAM

Refer to DTC P1115 on page [05-270](#).

INSPECTION PROCEDURE

CAUTION:

Be careful when replacing any part in the system or changing the coolant because the coolant in the heat storage tank is hot even if the engine and the radiator are cold.

HINT:

- The detection of this DTC may indicate that the coolant heat storage (CHS) tank outlet water temperature sensor stuck or the water valve stuck.
- If DTC P1121 is detected, coolant passages may be clogged.
- To check the coolant heat storage (CHS) system, the ECM may cause the water pump of the CHS system to operate 5 hours after the power switch has been turned OFF.
- Read freeze frame data using the intelligent tester II. Freeze frame data records the engine condition when malfunction is detected. When troubleshooting, it is useful for determining whether the vehicle was running or stopped, the engine was warmed up or not, the air-fuel ratio was lean or rich, etc. at the time of the malfunction.

Hand-held tester:**1 CHECK OTHER DTC OUTPUT(IN ADDITION TO DTC P1150)**

- (a) Connect the hand-held tester to the DLC3.
- (b) Turn the power switch ON (IG).
- (c) Turn the hand-held tester ON.
- (d) On the hand-held tester, select the item: DIAGNOSIS / ENHANCED OBD II / ENGINE AND ECT / DTC INFO / CURRENT CODES.
- (e) Read DTCs.

Result:

Display (DTC Output)	Proceed to
P1150	A
P1150 and other DTCs	B

HINT:

If any other codes besides P1150 are output, perform troubleshooting for those DTCs first.

B

GO TO RELEVANT DTC CHART
(See page [05-55](#))

A**2 PERFORM ACTIVE TEST BY HAND-HELD TESTER**

- (a) Connect the hand-held tester to the DLC3.
- (b) Turn the power switch ON (IG).
- (c) Turn the hand-held tester ON.
- (d) Put the engine in inspection mode (see page [05-1](#)).
- (e) Start the engine and warm it up.
- (f) Select the items: DIAGNOSIS / ENHANCED OBD II / ENGINE AND ECT / ACTIVE TEST / WATER FLW VLV3, WATER FLW VLV4 and WATER FLW VLV5.
- (g) Measure the voltage between terminals WBAD and E2 of the ECM connector.

Standard:

Tester Operation	Specified Condition
"WATER FLW VLV 3" ON	Approximately 2.5 V
"WATER FLW VLV 4" ON	Approximately 3.5 V
"WATER FLW VLV 5" ON	Approximately 4.5 V

NG

REPLACE WATER W/BRACKET VALVE ASSY

OK

3 INSPECT TEMPERATURE SENSOR

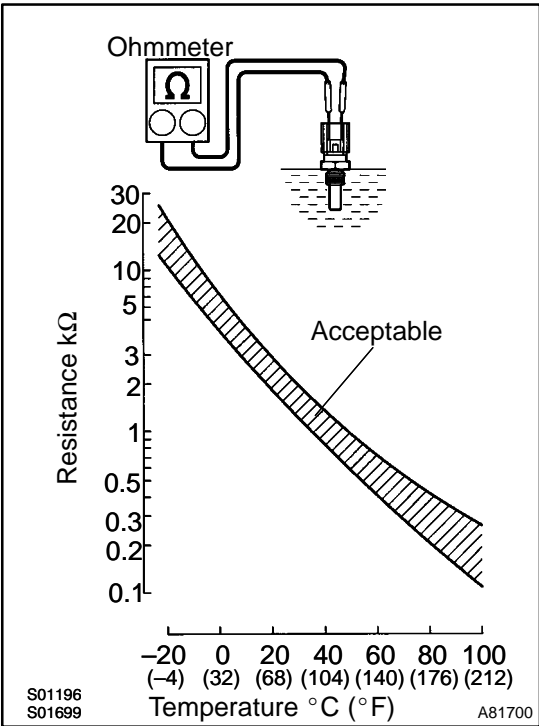

- (a) Remove the CHS tank outlet temperature sensor.
- (b) Measure the resistance between the terminals.

Resistance:

Tester Connection	Specified Condition
1 - 2	2 to 3 kΩ at 20°C (68°F)
1 - 2	0.2 to 0.4 kΩ at 80°C (176°F)

NOTICE:

In case of checking the CHS tank outlet temperature sensor in water, be careful not to allow water to contact the terminals. After checking, dry the sensor.

HINT:

Alternate procedure: Connect an ohmmeter to the installed CHS tank outlet temperature sensor and read the resistance. Use an infrared thermometer to measure the CHS tank outlet temperature in the immediate vicinity of the sensor. Compare these values to the resistance/temperature graph. Change the engine temperature (warm up or allow to cool down) and repeat the test.

- (c) Reinstall the CHS tank outlet temperature sensor.

NG → **REPLACE TEMPERATURE SENSOR**

OK

4 CHECK COOLING SYSTEM(CHECK FOR CLOGGING IN THE COOLANT SYSTEM)

OK: Coolant passages are not clogged.

NG → **REPAIR OR REPLACE COOLING SYSTEM COMPONENT**

OK

REPLACE ECM (See page 10-24)

OBD II scan tool (excluding hand-held tester):

1 CHECK OTHER DTC OUTPUT(IN ADDITION TO DTC P1150)

- (a) Connect the OBD II scan tool to the DLC3.
- (b) Turn the power switch ON (IG).
- (c) Turn the OBD II scan tool ON.
- (d) Read DTCs using the OBD II scan tool.

Result:

Display (DTC Output)	Proceed to
P1150	A
P1150 and other DTCs	B

HINT:

If any other codes besides P1150 are output, perform troubleshooting for those DTCs first.

B **GO TO RELEVANT DTC CHART**
(See page 05-55)

A

2 INSPECT TEMPERATURE SENSOR

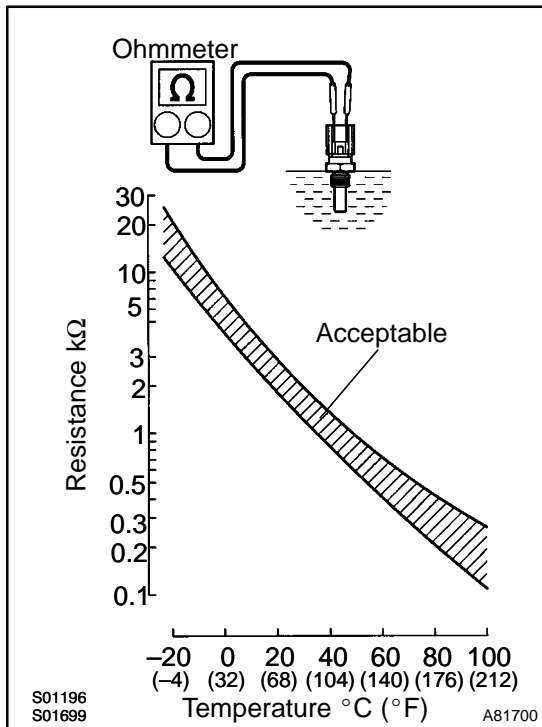

- (a) Remove the CHS tank outlet temperature sensor.
- (b) Measure the resistance between the terminals.

Resistance:

Tester Connection	Specified Condition
1 - 2	2 to 3 kΩ at 20°C (68°F)
1 - 2	0.2 to 0.4 kΩ at 80°C (176°F)

NOTICE:

In case of checking the CHS tank outlet temperature sensor in water, be careful not to allow water to contact the terminals. After checking, dry the sensor.

HINT:

Alternate procedure: Connect an ohmmeter to the installed CHS tank outlet temperature sensor and read the resistance. Use an infrared thermometer to measure the CHS tank outlet temperature in the immediate vicinity of the sensor. Compare these values to the resistance/temperature graph. Change the engine temperature (warm up or allow to cool down) and repeat the test.

- (c) Reinstall the CHS tank outlet temperature sensor.

NG **REPLACE TEMPERATURE SENSOR**

OK

3 CHECK HARNESS AND CONNECTOR

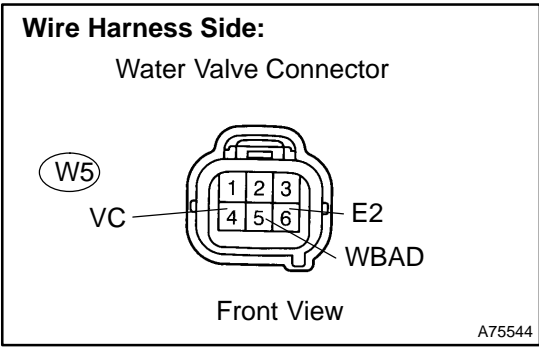

- (a) Disconnect the W5 water valve connector.
- (b) Disconnect the E4 and E7 ECM connectors.
- (c) Check the resistance between the wire harness side connectors.

Standard (Check for open):

Tester Connection	Specified Condition
Water valve (W5-5) – WBAD (E7-20)	Below 1 Ω
Water valve (W5-4) – VC (E4-18)	Below 1 Ω
Water valve (W5-6) – E2 (E4-28)	Below 1 Ω

Standard (Check for short):

Tester Connection	Specified Condition
Water valve (W5-5) or WBAD (E7-20) – Body ground	10 kΩ or higher

- (d) Reconnect the water valve connector.
- (e) Reconnect the ECM connectors.

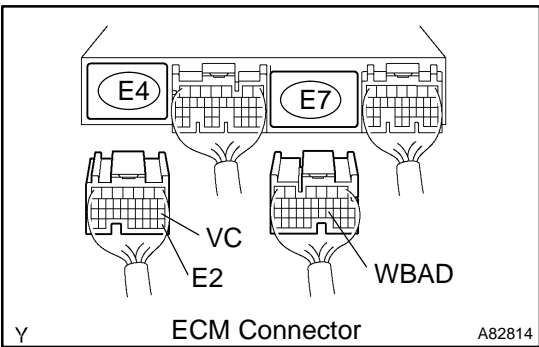

NG → **REPAIR OR REPLACE HARNESS OR CONNECTOR**

OK

4 CHECK COOLING SYSTEM

OK: Coolant passages are not clogged.

NG → **REPAIR OR REPLACE COOLING SYSTEM**

OK

5 REPLACE WATER W/BRACKET VALVE ASSY

GO

6 PERFORM SIMULATION TEST

- (a) Put the engine in inspection mode and start the engine.
- (b) Warm up the engine until the engine coolant temperature reaches more than 85°C (185 °F).
- (c) Cool the engine down completely.
- (d) Perform the steps (a) to (c) twice.

GO

7	READ OUTPUT DTCS
----------	-------------------------

- (a) Connect the OBD II scan tool to the DLC3.
- (b) Turn the power switch ON (IG).
- (c) Turn the OBD II scan tool ON.
- (d) Read DTCs using the OBD II scan tool.

Result:

Display (DTC Output)	Proceed to
No output	A
DTC P1150	B

B

REPLACE ECM (See page 10-24)

A

SYSTEM OK
