

DTC	P0110	INTAKE AIR TEMPERATURE CIRCUIT
------------	--------------	---------------------------------------

DTC	P0112	INTAKE AIR TEMPERATURE CIRCUIT LOW INPUT
------------	--------------	---

DTC	P0113	INTAKE AIR TEMPERATURE CIRCUIT HIGH INPUT
------------	--------------	--

CIRCUIT DESCRIPTION

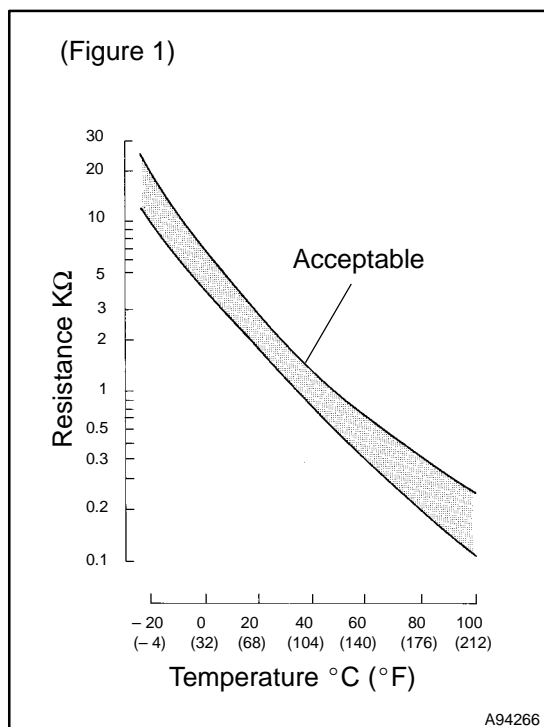

The intake air temperature (IAT) sensor, mounted on the mass air flow (MAF) meter, monitors the intake air temperature. The IAT sensor has a thermistor that varies its resistance depending on the temperature of the intake air. When the air temperature is low, the resistance in the thermistor increases. When the temperature is high, the resistance drops. The variations in resistance are reflected as voltage changes to the ECM terminal (see Figure 1).

The intake air temperature sensor is connected to the ECM (see wiring diagram). The 5 V power source voltage in the ECM is applied to the intake air temperature sensor from terminal THA (THAR) via resistor R.

That is, the resistor R and the intake air temperature sensor are connected in series. When the resistance value of the intake air temperature sensor changes in accordance with changes in the intake air temperature, the voltage at terminal THA (THAR) also changes. Based on this signal, the ECM increases the fuel injection volume to improve the driveability during cold engine operation.

DTC No.	Proceed to	DTC Detection Condition	Trouble Area
P0110	Step 1	Open or short in intake air temperature sensor circuit for 0.5 second	<ul style="list-style-type: none"> • Open or short in intake air temperature sensor circuit • Intake air temperature sensor (built in mass air flow meter) • ECM
P0112	Step 4	Short in intake air temperature sensor circuit for 0.5 second	<ul style="list-style-type: none"> • Short in intake air temperature sensor circuit • Intake air temperature sensor (built in mass air flow meter) • ECM
P0113	Step 2	Open in intake air temperature sensor circuit for 0.5 second	<ul style="list-style-type: none"> • Open in intake air temperature sensor circuit • Intake air temperature sensor (built in mass air flow meter) • ECM

HINT:

After confirming DTC P0110, P0112 or P0113, confirm the intake air temperature in DIAGNOSIS / ENHANCED OBD II / ENGINE AND ECT / DATA LIST / ALL using the hand-held tester or the OBD II scan tool.

Temperature Displayed	Malfunction
-40°C (-40°F)	Open circuit
140°C (284°F)	Short circuit

MONITOR DESCRIPTION

The ECM monitors the sensor voltage and uses this value to calculate the intake air temperature. When the sensor output voltage deviates from the normal operating range, the ECM interprets this as a fault in the IAT sensor and sets a DTC.

Example:

When the sensor voltage output is equal to -40°C (-40°F), or more than 140°C (284°F), and either condition continues for 0.5 second or more.

MONITOR STRATEGY

Related DTCs	P0110: Intake air temperature sensor range check (fluttering) P0112: Intake air temperature sensor range check (low resistance) P0113: Intake air temperature sensor range check (high resistance)
Required sensors/components	Intake air temperature sensor
Frequency of operation	Continuous
Duration	0.5 second
MIL operation	Immediately
Sequence of operation	None

TYPICAL ENABLING CONDITIONS

The monitor will run whenever the following DTCs are not present	See page 05-20
--	----------------

TYPICAL MALFUNCTION THRESHOLDS

P0110: Intake air temperature sensor range check (fluttering)

Intake air temperature sensor resistance (Intake air temperature)	Less than $98.5\ \Omega$ or more than $156\ \text{k}\Omega$ (More than 140°C (284°F) or -40°C (-40°F) or less)
---	---

P0112: Intake air temperature sensor range check (low resistance)

Intake air temperature sensor resistance (Intake air temperature)	Less than $98.5\ \Omega$ (More than 140°C (284°F))
---	---

P0113: Intake air temperature sensor range check (high resistance)

Intake air temperature sensor resistance (Intake air temperature)	More than $156\ \text{k}\Omega$ (-40°C (-40°F) or less)
---	---

COMPONENT OPERATING RANGE

Intake air temperature sensor resistance	$98.5\ \Omega$ (140°C (284°F)) to $156\ \text{k}\Omega$ (-40°C (-40°F))
--	---

WIRING DIAGRAM

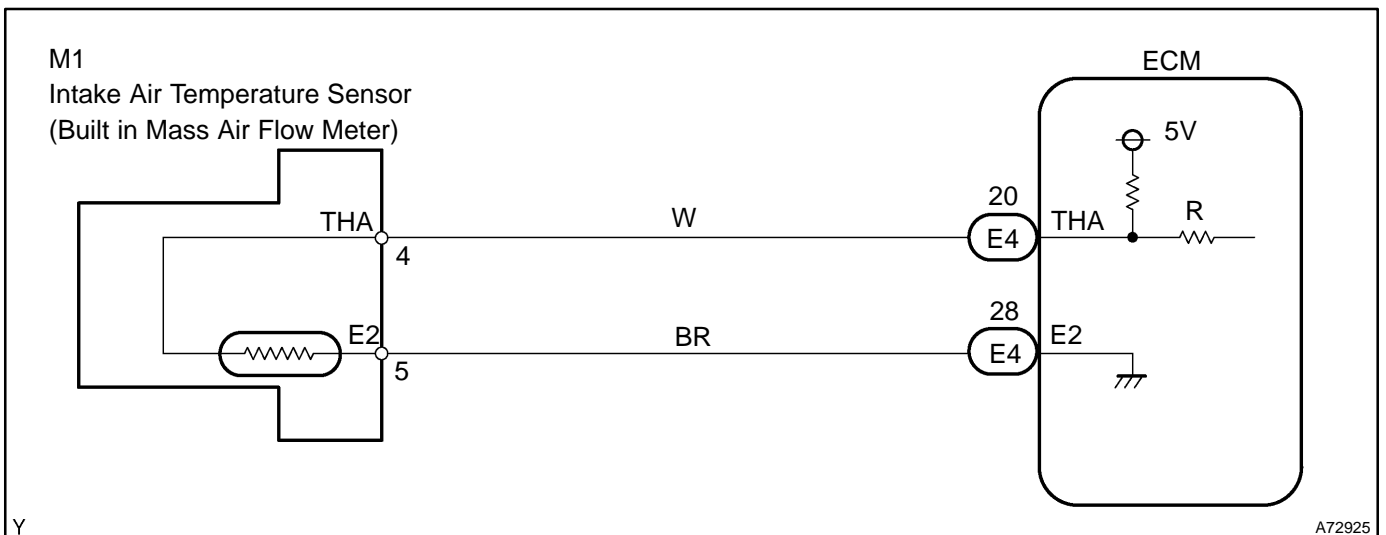

INSPECTION PROCEDURE

HINT:

- If DTCs related to different systems that have terminal E2 as the ground terminal are output simultaneously, terminal E2 may have an open circuit.
- Read freeze frame data using the hand-held tester or the OBD II scan tool. Freeze frame data records the engine condition when malfunction is detected. When troubleshooting, it is useful for determining whether the vehicle was running or stopped, the engine was warmed up or not, the air-fuel ratio was lean or rich, etc. at the time of the malfunction.

1	READ VALUE OF HAND-HELD TESTER OR OBD II SCAN TOOL(INTAKE AIR TEMPERATURE)
----------	---

- Connect the hand-held tester or the OBD II scan tool to the DLC3.
- Turn the power switch ON (IG).
- Turn the hand-held tester or the OBD II scan tool ON.
- On the hand-held tester, select the item: DIAGNOSIS / ENHANCED OBD II / ENGINE AND ECT / DATA LIST / ALL / INTAKE AIR.
- Read the value using the hand-held tester or the OBD II scan tool.

Temperature value: Same as the ambient air temperature.

Result:

Temperature Displayed	Proceed to
-40°C (-40°F)	A
140°C (284°F)	B
OK (Same as ambient air temperature)	C

HINT:

- If there is an open circuit, the hand-held tester or the OBD II scan tool indicates -40°C (-40°F).
- If there is a short circuit, the hand-held tester or the OBD II scan tool indicates 140°C (284°F).

B → Go to step 4

C → **CHECK FOR INTERMITTENT PROBLEMS**
(See page 05-17)

A

2 READ VALUE OF HAND-HELD TESTER OR OBD II SCAN TOOL(CHECK FOR OPEN IN WIRE HARNESS)

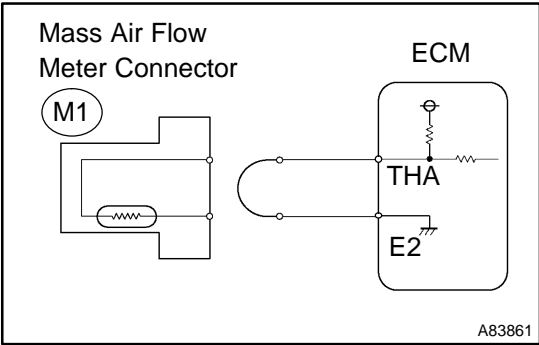

- (a) Disconnect the M1 mass air flow meter connector.
- (b) Connect terminals THA and E2 of the mass air flow meter wire harness side connector.
- (c) Turn the power switch ON (IG).
- (d) On the hand-held tester, select the item: DIAGNOSIS / ENHANCED OBD II / ENGINE AND ECT / DATA LIST / ALL / INTAKE AIR. Read the value.
OK:
Temperature value: 140°C (284°F)
- (e) Reconnect the mass air flow meter connector.

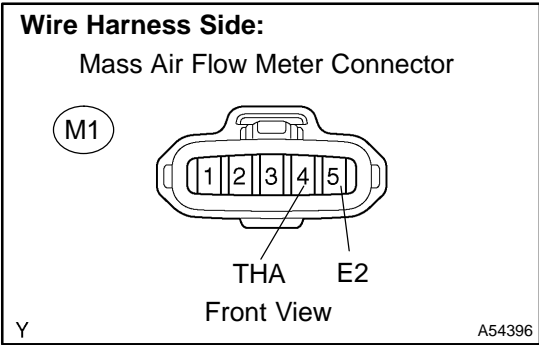

OK **CONFIRM GOOD CONNECTION AT SENSOR. IF OK, REPLACE MASS AIR FLOW SENSOR**

NG

3 READ VALUE OF HAND-HELD TESTER OR OBD II SCAN TOOL(CHECK FOR OPEN IN ECM)

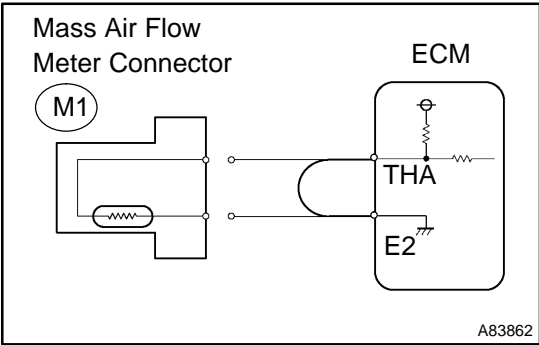

- (a) Disconnect the M1 mass air flow meter connector.
- (b) Connect terminals THA and E2 of the E4 ECM connector.
HINT:
Before checking, do a visual and contact pressure check for the ECM connector.
- (c) Turn the power switch ON (IG).
- (d) On the hand-held tester, select the item: DIAGNOSIS / ENHANCED OBD II / ENGINE AND ECT / DATA LIST / ALL / INTAKE AIR. Read the value.
OK:
Temperature value: 140°C (284°F)
- (e) Reconnect the mass air flow meter connector.

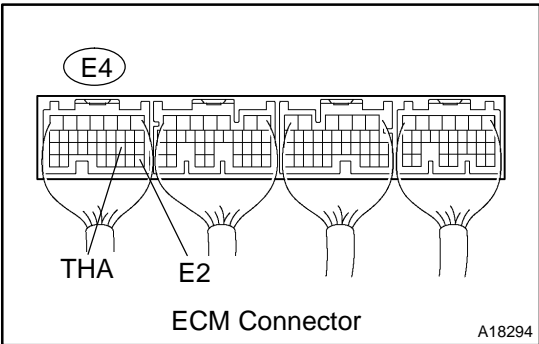

OK REPAIR OR REPLACE HARNESS OR CONNECTOR

NG

CONFIRM GOOD CONNECTION AT ECM. IF OK, REPLACE ECM (See page 10-24)

4 READ VALUE OF HAND-HELD TESTER OR OBD II SCAN TOOL(CHECK FOR SHORT IN WIRE HARNESS)

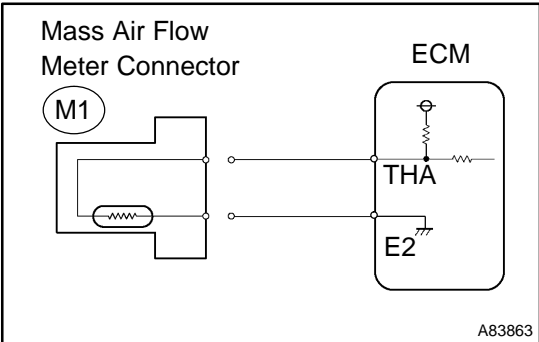

- (a) Disconnect the M1 mass air flow meter connector.
 - (b) Turn the power switch ON (IG).
 - (c) On the hand-held tester, select the item: DIAGNOSIS / ENHANCED OBD II / ENGINE AND ECT / DATA LIST / ALL / INTAKE AIR. Read the value.
- OK:**
Temperature value: -40°C (-40°F)
- (d) Reconnect the mass air flow meter connector.

OK REPLACE MASS AIR FLOW METER

NG

5 READ VALUE OF HAND-HELD TESTER OR OBD II SCAN TOOL(CHECK FOR SHORT IN ECM)

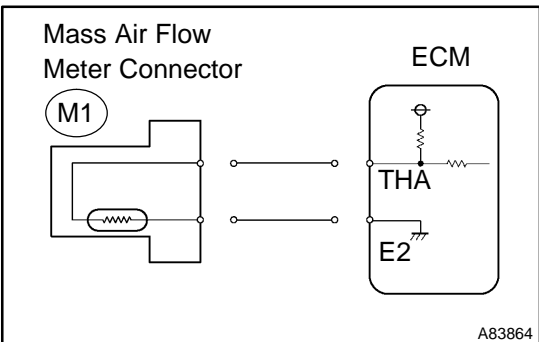

- (a) Disconnect the E4 ECM connector.
 - (b) Turn the power switch ON (IG).
 - (c) On the hand-held tester, select the item: DIAGNOSIS / ENHANCED OBD II / ENGINE AND ECT / DATA LIST / ALL / INTAKE AIR. Read the value.
- OK:**
Temperature value: -40°C (-40°F)
- (d) Reconnect the ECM connector.

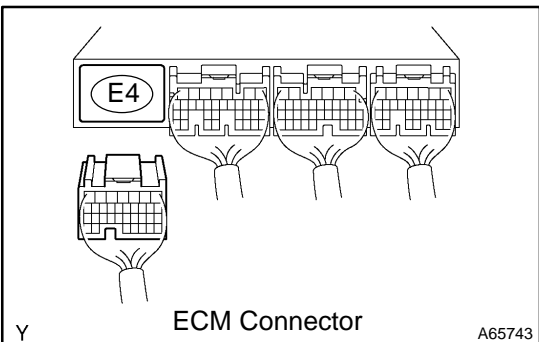

OK REPAIR OR REPLACE HARNESS OR CONNECTOR

NG

REPLACE ECM (See page 10-24)